

#### DESCRIPTION

The A705 is a low dropout current regulator rated for 210mA, 230mA, 250mA, 270mA, and 290mA constant sink current. The low quiescent current and low dropout voltage are achieved by advanced Bi-CMOS process.

#### FEATURES

- Only bypass capacitor is required.
- 210/230/250/270/290mA constant sink current.
- Output short / open circuit protection.
- Low dropout voltage.
- Low quiescent current.
- Supply voltage range 2.7V ~ 12V.
- 2KV HBM ESD protection.
- Advanced Bi-CMOS process.
- SOT-89 and TO-252 package available.

#### TYPICAL APPLICATION CIRCUIT

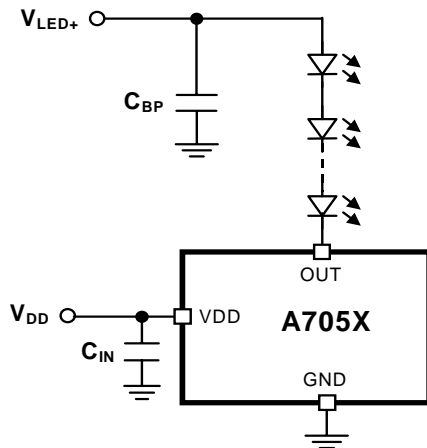

#### APPLICATIONS

- Power LED Driver
- LED Cap-Lamp

#### PACKAGE PIN OUT

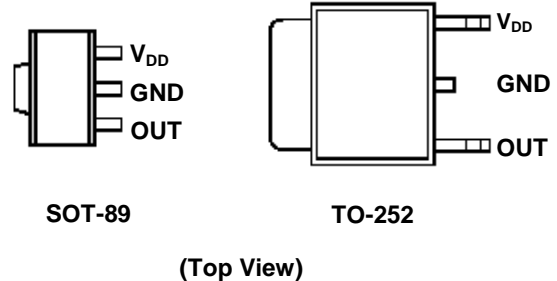

#### ORDER INFORMATION

Output Current	N	SOT-89	S	TO-252
		3-pin		3-pin
200mA ~ 220mA		A705NFT-210		A705SFT-210
220mA ~ 240mA		A705NFT-230		A705SFT-230
240mA ~ 260mA		A705NFT-250		A705SFT-250
260mA ~ 280mA		A705NFT-270		A705SFT-270
280mA ~ 300mA		A705NFT-290		A705SFT-290

Note: The letter "F" is marked for Lead Free process, and letter "T" is marked for Tape & Reel.

**ABSOLUTE MAXIMUM RATINGS** (Note)

Input Voltage, $V_{DD}$	-0.3V to 13.2V
Output Voltage, $V_{OUT}$	-0.3V to 17V
Maximum Junction Temperature, $T_J$	150°C
Storage Temperature Range	-40°C to 150°C
Lead Temperature (Soldering, 10 seconds)	260°C

Note: Exceeding these ratings could cause damage to the device. All voltages are with respect to Ground.  
 Currents are positive into, negative out of the specified terminal.

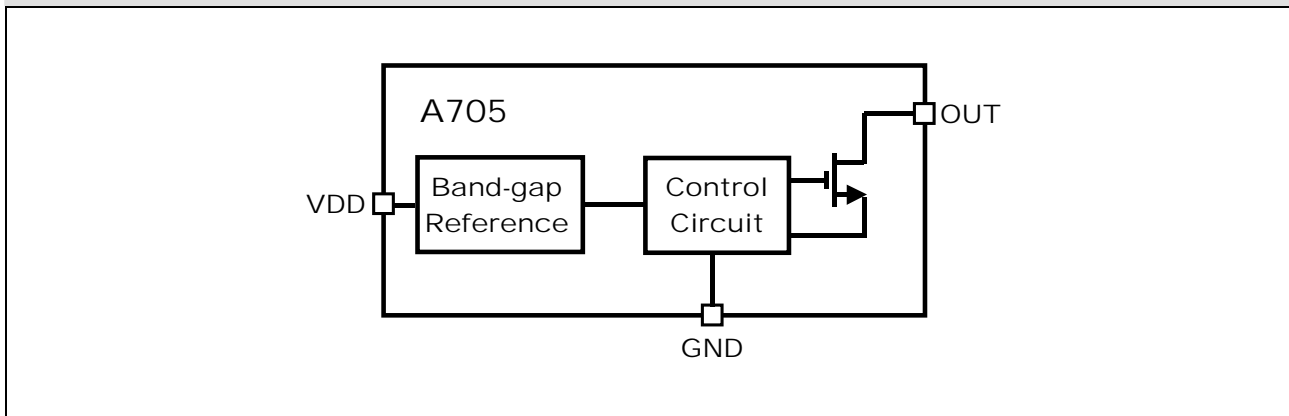
**BLOCK DIAGRAM**

**PIN DESCRIPTION**

Pin Name	Pin Function
$V_{DD}$	Power supply.
OUT	Output pins. Connected to load.
GND	Ground.

**THERMAL RESISTANCE**

Package		$\theta_{JT}$ (°C/W)	Note: $T_J = T_C + (P_D \times \theta_{JT})$ $\theta_{JT}$ : Thermal Resistance - Junction to Tab. $T_C$ : Case (Tab) Temperature. $T_J$ : Junction Temperature. $P_D$ : Power Consumption.
N	SOT-89	35	
S	TO-252	7	

**RECOMMENDED OPERATING CONDITIONS**

Parameter	Symbol	Min	Typ	Max	Unit
Supply Voltage	$V_{DD}$	2.7		12	V
Output Sink Current	$I_{OUT}$			260	mA
Operating Free-air Temperature Range	$T_A$	-40		+85	°C

**DC ELECTRICAL CHARACTERISTICS**

$V_{DD}=3.7V$ , $T_A=25^\circ C$ , No Load (Unless otherwise noted)								
Parameter	Symbol	Condition	Min	Typ	Max	Unit	Apply Pin	
Output Sink Current	$I_{OUT}$	$V_{OUT}=0.2V$	A705P	200	210	220	mA	OUT
			A705Q	220	230	240		
			A705R	240	250	260		
			A705S	260	270	280		
			A705T	280	290	300		
Load Regulation		$V_{OUT}=0.2V$ to $3V$			2	mA/V		
Line Regulation		$V_{DD}= 3V$ to $12V$ , $V_{OUT}=0.2V$			2	mA/V		
Output Dropout Voltage <sup>(Note)</sup>	$V_{OUTL}$			120		mV		
Supply Current Consumption	$I_{DD}$			200		uA	VDD	

Note: Output dropout voltage:  $90\% \times I_{OUT}$  @  $V_{OUT}=200mV$

---

**APPLICATION INFORMATION**

---

**The Maximum Power Dissipation on Regulator:**

$$P_{D(MAX)} = V_{OUT(MAX)} \times I_{OUT(NOM)} + V_{IN(MAX)} \times I_Q$$

$V_{OUT(MAX)}$  = the maximum voltage on output pin;

$I_{OUT(NOM)}$  = the nominal output current;

$I_Q$  = the quiescent current the regulator consumes at  $I_{OUT(MAX)}$ ;

$V_{IN(MAX)}$  = the maximum input voltage.

**Thermal Consideration:**

The A705 has internal power and thermal limiting circuitry designed to protect the device under overload conditions. However, maximum junction temperature ratings should not be exceeded under continuous normal load conditions. The thermal protection circuit of A705 prevents the device from damage due to excessive power dissipation. When the device temperature rises to approximately 150°C, the regulator will be turned off. When power consumption is over about 700mW (SOT-89 package, at  $T_A=70^\circ\text{C}$ ) or 1000mW (TO-252 package, at  $T_A=70^\circ\text{C}$ ), additional heat sink is required to control the junction temperature below 120°C.

The junction temperature is:

$$T_J = P_D (\theta_{JT} + \theta_{CS} + \theta_{SA}) + T_A$$

$P_D$  : Dissipated power.

$\theta_{JT}$  : Thermal resistance from the junction to the mounting tab of the package.

$\theta_{CS}$  : Thermal resistance through the interface between the IC and the surface on which it is mounted.  
(typically,  $\theta_{CS} < 1.0^\circ\text{C/W}$ )

$\theta_{SA}$  : Thermal resistance from the mounting surface to ambient (thermal resistance of the heat sink).

If PC Board copper is going to be used as a heat sink, below table can be used to determine the appropriate size of copper foil required. For multi-layered PCB, these layers can also be used as a heat sink. They can be connected with several through-hole vias.

PCB $\theta_{SA}$ ( $^\circ\text{C/W}$ )	59	45	38	33	27	24	21
PCB heat sink size ( $\text{mm}^2$ )	500	1000	1500	2000	3000	4000	5000

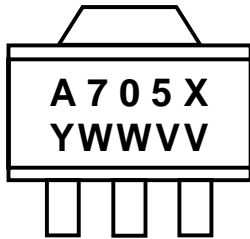
**PACKAGE**
**Top Marking for SOT-89**

**X : Output Current Options**

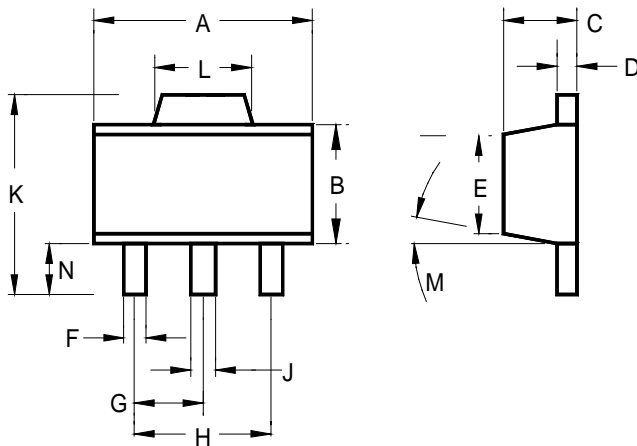
P = 210mA; Q = 230mA; R = 250mA; S = 270mA; T = 290mA

**Y : Year Code**
**WW : Week Code**
**V : Vendor Code**
**3-Pin Surface Mount SOT-89**

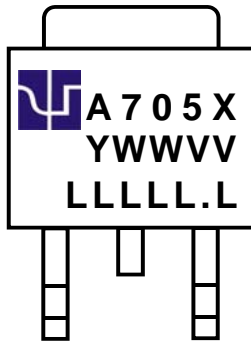
	INCHES			MILLIMETERS		
	MIN	TYP	MAX	MIN	TYP	MAX
A	0.173	-	0.181	4.39	-	4.59
B	0.090	-	0.102	2.28	-	2.59
C	0.055	-	0.063	1.39	-	1.60
D	0.015	-	0.017	0.38	-	0.43
E	0.084	-	0.090	2.13	-	2.28
F	0.016	-	0.019	0.33	-	0.48
G	0.059 BSC			1.49 BSC		
H	0.118 BSC			2.99 BSC		
J	0.018	-	0.022	0.45	-	0.55
K	0.155	-	0.167	3.94	-	4.24
L	0.067	-	0.072	1.70	-	1.82
M	0°	-	8°	0°	-	8°
N	0.035	-	0.047	0.89	-	1.19

**Top Marking for TO-252**

**X : Output Current Options**

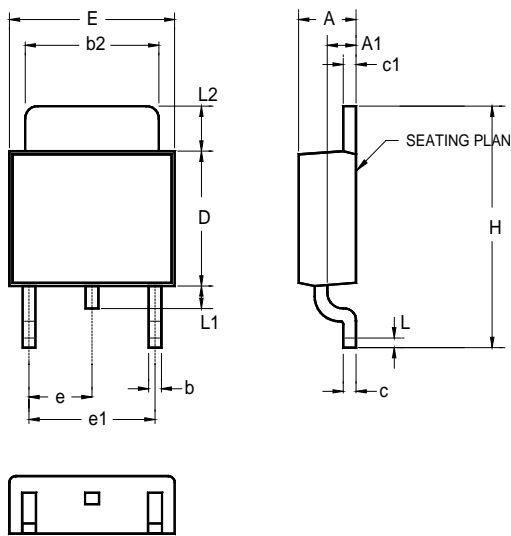
P = 210mA; Q = 230mA; R = 250mA; S = 270mA; T = 290mA

**Y : Year Code**
**WW : Week Code**
**V : Vendor Code**
**LLLLL.L : Lot Number**
**3-Pin Surface Mount TO-252**

	INCHES			MILLIMETERS		
	MIN	TYP	MAX	MIN	TYP	MAX
A	0.086	-	0.094	2.18	-	2.39
A1	0.040	-	0.050	1.02	-	1.27
b	-	0.024	-	-	0.61	-
b2	0.205	-	0.215	5.21	-	5.46
c	0.018	-	0.023	0.46	-	0.58
c1	0.018	-	0.023	0.46	-	0.58
D	0.210	-	0.220	5.33	-	5.59
E	0.250	-	0.265	6.35	-	6.73
e	0.090 BSC			2.29 BSC		
e1	0.180 BSC			4.58 BSC		
H	0.370	-	0.410	9.40	-	10.41
L	0.020	-	-	0.51	-	-
L1	0.025	-	0.040	0.64	-	1.02
L2	0.060	-	0.080	1.52	-	2.03

### **IMPORTANT NOTICE**

ADDtek reserves the right to make changes to its products or to discontinue any integrated circuit product or service without notice, and advises its customers to obtain the latest version of relevant information to verify, before placing orders, that the information being relied on is current.

A few applications using integrated circuit products may involve potential risks of death, personal injury, or severe property or environmental damage. ADDtek integrated circuit products are not designed, intended, authorized, or warranted to be suitable for use in life-support applications, devices or systems or other critical applications. Use of ADDtek products in such applications is understood to be fully at the risk of the customer. In order to minimize risks associated with the customer's applications, the customer should provide adequate design and operating safeguards.

ADDtek assumes no liability to customer product design or application support. ADDtek warrants the performance of its products to the specifications applicable at the time of sale.

---

**ADDtek Corp.**  
9F, No. 20, Sec. 3, Bade Rd., Taipei, Taiwan, 105  
TEL: 2-25700299  
FAX: 2-25700196

---