

## High Performance *ActivePSR™* Primary Switching Regulator

### FEATURES

- Patented Primary Side Regulation Technology
- No Opto-Coupler
- Best-in-Class Constant Voltage, Constant Current Accuracy
- Low EMI
- Proprietary Fast Startup Circuit
- Built-in Soft-Start Circuit
- Integrated Line and Primary Inductance Compensation
- Integrated Programmable Output Load Resistance Compensation
- Line Under-Voltage, Output Over-Voltage, Output Short-Circuit and Over-Temperature Protection
- Complies with all Global Energy Efficiency and CEC Average Efficiency Standards
- Adjustable power from 2W to 7W
- Minimum External Components
- Tiny SOT23-6 Package

### APPLICATIONS

- Chargers for Cell Phones, PDAs, MP3, Portable Media Players, DSCs, and Other Portable Devices and Appliances
- RCC Adapter Replacements
- Linear Adapter Replacements
- Standby and Auxiliary Supplies

### GENERAL DESCRIPTION

The ACT361 belongs to the high performance patented *ActivePSR™* Family of Universal-input AC/DC off-line controllers for battery charger and adapter applications. It is designed for flyback topology working in discontinuous conduction mode (DCM). The ACT361 meets all of the global energy efficiency regulations (CEC, European Blue Angel, and US Energy Star standards) while using very few external components.

The ACT361 ensures safe operation with complete protection against all fault conditions. Built-in protection circuitry is provided for output short-circuit, output over-voltage, line under-voltage, and over temperature conditions.

The ACT361 *ActivePSR™* is optimized for high performance, cost-sensitive applications, and utilizes Active-Semi's proprietary primary-side feedback architecture to provide accurate constant voltage, constant current (CV/CC) regulation without the need of an opto-coupler or reference device. Integrated line and primary inductance compensation circuitry provides accurate constant current operation despite wide variations in line voltage and primary inductance. Integrated output load resistance compensation further enhances output accuracy. The ACT361 achieves excellent regulation and transient response, yet requires less than 150mW of standby power.

The ACT361 is optimized for 2W to 7W applications. It is available in space-saving 6 pin SOT23-6 package.

**Figure 1:**  
**Simplified Application Circuit**

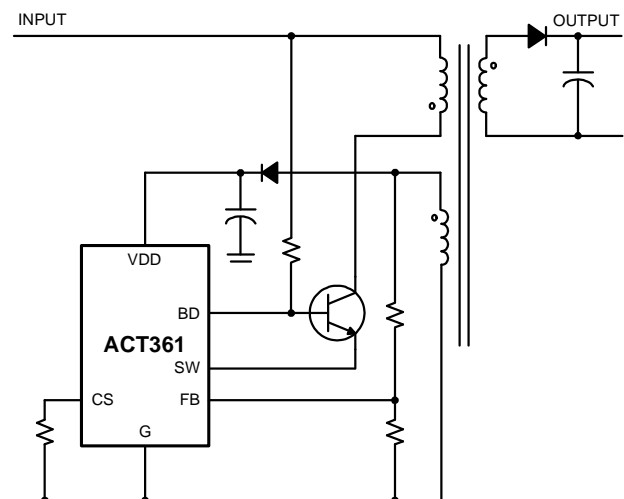

## ORDERING INFORMATION

PART NUMBER	TEMPERATURE RANGE	PACKAGE	PINS	PACKING METHOD	TOP MARK
ACT361US-T	-40°C to 85°C	SOT23-6	6	TAPE & REEL	FSCR

## PIN CONFIGURATION

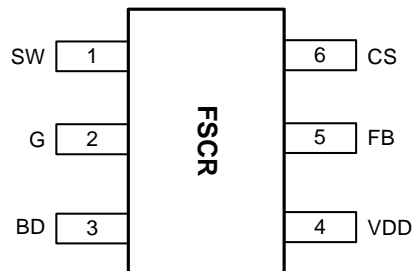

SOT23-6  
ACT361US-T

## PIN DESCRIPTIONS

PIN	NAME	DESCRIPTION
1	SW	Switch Drive. Switch node for the external NPN transistor. Connect this pin to the external power NPN's emitter. This pin also supplies current to VDD during startup.
2	G	Ground.
3	BD	Base Drive. Base driver for the external NPN transistor.
4	VDD	Power Supply. This pin provides bias power for the IC during startup and steady state operation.
5	FB	Feedback Pin. Connect this pin to a resistor divider network from the auxiliary winding.
6	CS	Current Sense Pin. Connect an external resistor ( $R_{CS}$ ) between this pin and ground to set peak current limit for the primary switch. The peak current limit is set by $(0.396V \times 0.9) / R_{CS}$ . For more detailed information, see Application Information.

**Figure 6:**  
**Universal VAC Input, 5V/0.7A Output Charger**

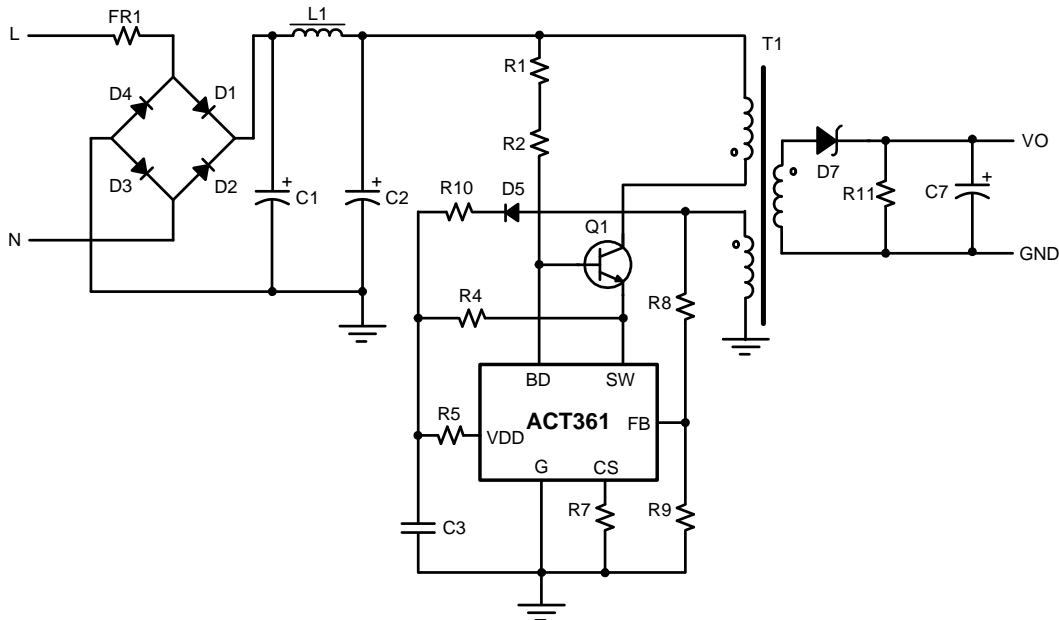
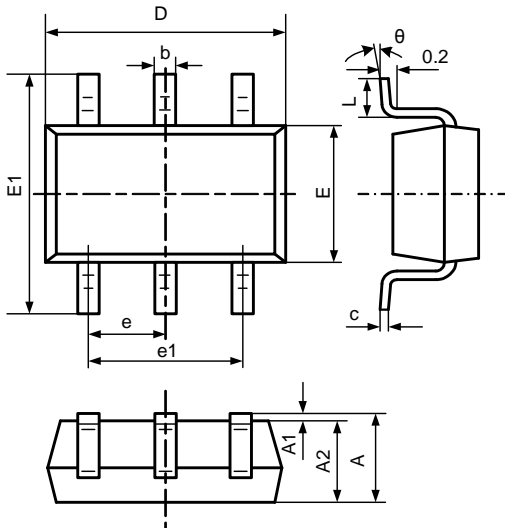

**Table 1:**  
**ACT361 Bill of Materials**

ITEM	REFERENCE	DESCRIPTION	QTY	MANUFACTURER
1	U1	IC, ACT361US-T, SOT23-6	1	Active-Semi
2	C1, C2	Capacitor, Electrolytic, 4.7 $\mu$ F/400V, 8 $\times$ 12mm	2	KSC
3	C3	Capacitor, Electrolytic, 4.7 $\mu$ F/35V, 5 $\times$ 11mm	1	POE
4	C7	Capacitor, Electrolytic, 470 $\mu$ F/10V, 8 $\times$ 12mm	1	KSC
5	D1-D4	Diode, Rectifier, 1000V/1A, 1N4007, DO-41	4	Good-Ark
6	D5	Diode, Ultra Fast, FR102,100V/1.0A, DO-41	1	Good-Ark
7	D7	Diode, Schottky, 40V/2A, SB240, DO-15	1	Good-Ark
8	L1	Axial Inductor, 1.5mH, 0410, DIP	1	Amode Tech
9	Q1	Transistor, NPN, 900V,1.5A, KSB13003AR, TO-92	1	Semi How
10	FR1	Fusible Resistor, 1W, 10 $\Omega$ , 5%	1	TY-OHM
11	R1, R2	Chip Resistor, 5.1M $\Omega$ , 1206, 5%	2	TY-OHM
12	R4	Chip Resistor, 150k, 0805, 5%	1	TY-OHM
13	R5	Chip Resistor, 22 $\Omega$ , 0603, 5%	1	TY-OHM
14	R7	Chip Resistor, 1.07 $\Omega$ , 1206, 1%	1	TY-OHM
15	R8	Chip Resistor, 53.6k, 0805, 1%	1	TY-OHM
16	R9	Chip Resistor, 9.76k, 0805, 1%	1	TY-OHM
17	R10	Chip Resistor, 22 $\Omega$ , 0805, 5%	1	TY-OHM
18	R11	Chip Resistor, 1.1k, 0805, 5%	1	TY-OHM
19	T1	Transformer, L <sub>p</sub> = 2.3mH $\pm$ 7%, EE16	1	

## PACKAGE OUTLINE

### SOT23-6 PACKAGE OUTLINE AND DIMENSIONS



SYMBOL	DIMENSION IN MILLIMETERS		DIMENSION IN INCHES	
	MIN	MAX	MIN	MAX
A	1.050	1.250	0.041	0.049
A1	0.000	0.100	0.000	0.004
A2	1.050	1.150	0.041	0.045
b	0.300	0.500	0.012	0.020
c	0.100	0.200	0.004	0.008
D	2.820	3.020	0.111	0.119
E	1.500	1.700	0.059	0.067
E1	2.650	2.950	0.104	0.116
e	0.950 TYP		0.037 TYP	
e1	1.800	2.000	0.071	0.079
L	0.700 REF		0.028 REF	
L1	0.300	0.600	0.012	0.024
θ	0°	8°	0°	8°

Active-Semi, Inc. reserves the right to modify the circuitry or specifications without notice. Users should evaluate each product to make sure that it is suitable for their applications. Active-Semi products are not intended or authorized for use as critical components in life-support devices or systems. Active-Semi, Inc. does not assume any liability arising out of the use of any product or circuit described in this datasheet, nor does it convey any patent license.

Active-Semi and its logo are trademarks of Active-Semi, Inc. For more information on this and other products, contact [sales@active-semi.com](mailto:sales@active-semi.com) or visit <http://www.active-semi.com>. For other inquiries, please send to:

2728 Orchard Parkway, San Jose, CA 95134-2012, USA