



Dual 2.2W Audio Amplifier Plus Stereo Headphone

CR4863 Series



General Description

The CR4863 is a dual bridge-connected audio power amplifier which, when connected to a 5V supply, will deliver 2.2W to a 4Ω load (Note 1) or 2.5W to a 3Ω load (Note 2) with less than 1.0% THD+N. In addition, the headphone input pin allows the amplifiers to operate in single-ended mode when driving stereo headphones.

Boomer audio power amplifiers were designed specifically to provide high quality output power from a surface mount package while requiring few external components. To simplify audio system design, the CR4863 combines dual bridge speaker amplifiers and stereo headphone amplifiers on one chip.

The CR4863 features an externally controlled, low-power consumption shutdown mode, a stereo headphone amplifier mode, and thermal shutdown protection. It also utilizes circuitry to reduce "clicks and pops" during device turn-on.

Note 1: An CR4863MTE that has been properly mounted to a circuit board will deliver 2.2W into 4Ω. The other package options for the CR4863 will deliver 1.1W into 8Ω. See the Application Information sections for further information concerning the CR4863MTE.

Note 2: An CR4863MTE that has been properly mounted to a circuit board and forced-air cooled will deliver 2.5W into 3Ω.

Feature

- Stereo headphone amplifier mode
- Thermal shutdown protection circuit
- "Click and pop" suppression circuit
- TSSOP-20 (173mil) Pb-Free Packaging
- Unity-gain stable
- TSSOP-20 Exposed-DAP Pb-Free Packag

Application

- Multimedia Monitors
- Portable DVD/VCD
- Portable Televisions
- Portable and Desktop Computers

Typical Application

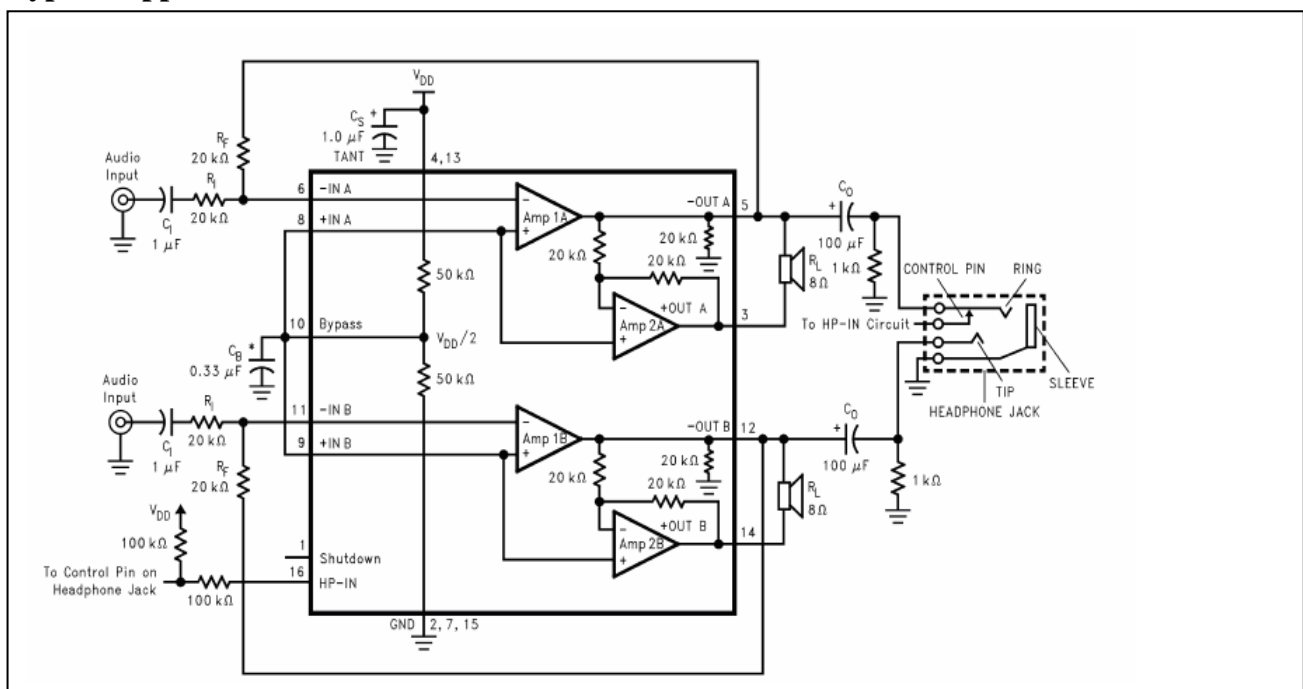



Pin Assignment

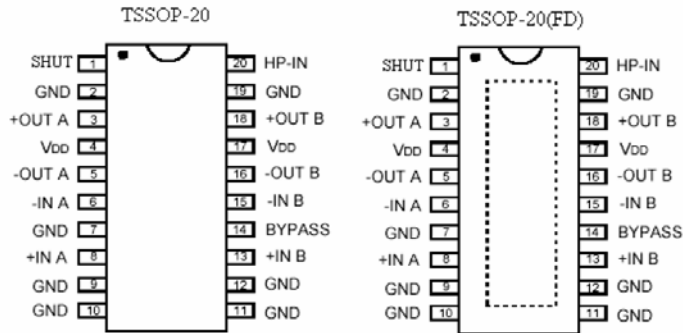

ELECTRICAL CHARACTERISTICS

Absolute Maximum Ratings

Symbol	Parameter	Min.	Max.	Units
V _{DD}	DC Supply Voltage	--	7.0	V
V _{IN}	Input Voltage	-0.3	V _{DD} +0.3	V
P _D	Power Dissipation	Internally Limited		
	ESD Susceptibility(HBM Model)	--	2000	V
T _J	Junction Temperature	--	150	°C
T _S	Storage Temperature	-55	150	°C

Note: Stress above those listed may cause permanent to the devices

Recommended Operating Conditions(T_A=25°C)

Symbol	Parameter	Condition	Min.	Typ.	Max.	Unit
V _{DD}	DC Supply Voltage		2.0	--	5.5	V
T _a	Temperature Range		-40	--	85	°C

Electrical Characteristics for Bridge-Mode Operation(T_A=25°C, V_{DD}=5V)

Symbol	Parameter	Condition	Min.	Typ.	Max.	Unit
I _{DD}	Quiescent Power Supply Current	V _{IN} =0V, I _O =0A, HP-IN=0V	6	15.7	20	m A
		V _{IN} =0V, I _O =0A, HP-IN=4V	--	8.5	--	
I _{SD}	Shutdown Current	V _{DD} applied to the Shut Pin	2	0.7	--	μA
V _{IH}	Headphone High Input Voltage		4	--	--	V
V _{IL}	Headphone Low Input Voltage		--	--	0.8	V
V _{OS}	Output Offset Volt.	V _{IN} =0V	--	5	50	m A
P _O	Output Power (THD=1%, f=1KHZ)	RL=3Ω(TSSOP-20FD)	--	2.5	--	W
		RL=4Ω(TSSOP-20FD)	--	2.2	--	
		RL=8Ω	--	1.1	--	
P _O	Output Power (THD+N=10%, f=1KHZ)	RL=3Ω(TSSOP-20FD)	--	3.2	--	W
		RL=4Ω(TSSOP-20FD)	--	2.7	--	
		RL=8Ω	--	1.5	--	
PSRR	Power Supply Rejection Ratio	V _{DD} =5V, RL=8Ω, C _B =1μF V _{RIPPLE} =200mV _{RMS}	--	66	--	d B
SNR	Signal to Noise Ratio	V _{DD} =5V, P _O =1.1W, RL=8Ω	--	96	--	d B
X _{TALK}	Channel Separation	f=1KHZ, CB=1μF	--	89	--	d B



Typical Performance Characteristics for TSSOP-20FD

THD+N vs Output Power

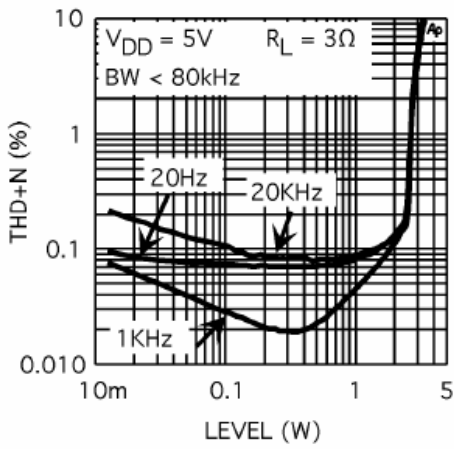

THD+N vs Frequency

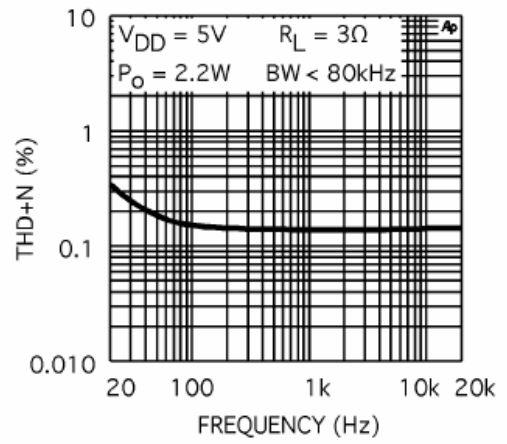

THD+N vs Output Power

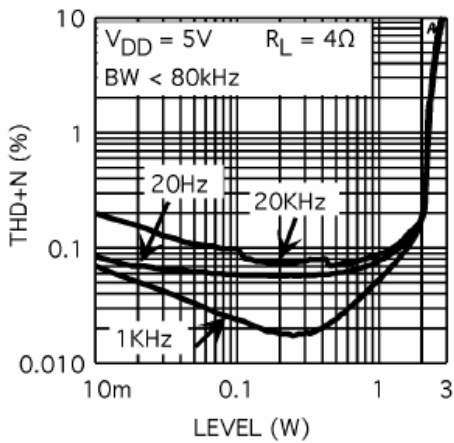

THD+N vs Frequency

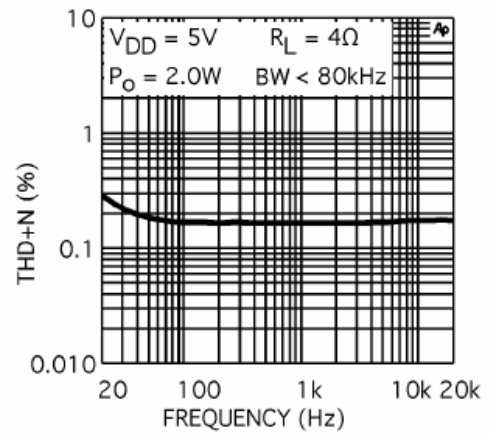

Power Dissipation vs Power Output

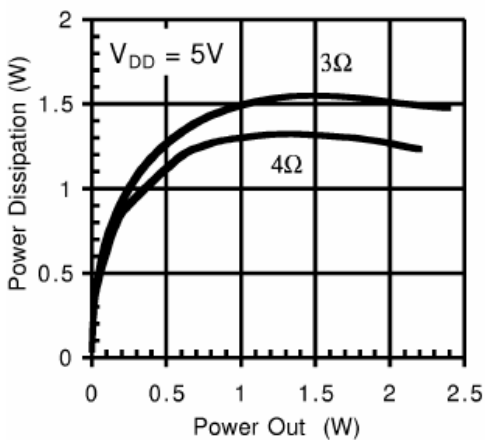

Power Derating Curve

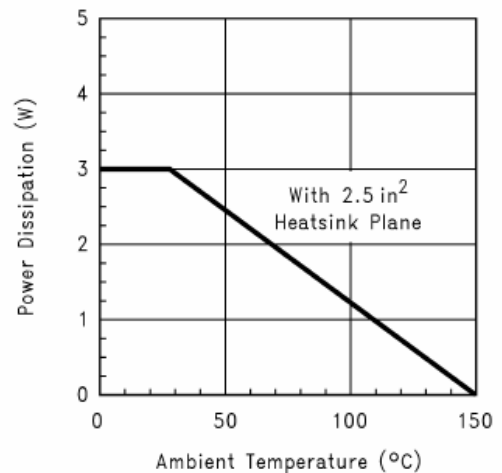



Packaging Information

