

1MHz, 2.5A Step-Up Current Mode PWM Converter



General Description

The FP6291 is a current mode boost DC-DC converter. Its PWM circuitry with built-in 0.2Ω power MOSFET make this regulator highly power efficient. The internal compensation network also minimizes as much as 6 external component counts. The non-inverting input of error amplifier connects to a 0.6V precision reference voltage and internal soft-start function can reduce the inrush current.

The FP6291 is available in the SOT23-6L package and provides space-saving PCB for the application fields.

Features

- Adjustable Output up to 12V
- Internal Fixed PWM frequency: 1.0MHz
- Precision Feedback Reference Voltage: 0.6V ($\pm 2\%$)
- Internal 0.2Ω, 2.5A, 16V Power MOSFET
- Shutdown Current: 0.1μA
- Over Temperature Protection
- Over Voltage Protection
- Adjustable Over Current Protection: 0.5A ~ 2.5A
- Package: SOT23-6L

Applications

- Chargers
- LCD Displays
- Digital Cameras
- Handheld Devices
- Portable Products

Typical Application Circuit

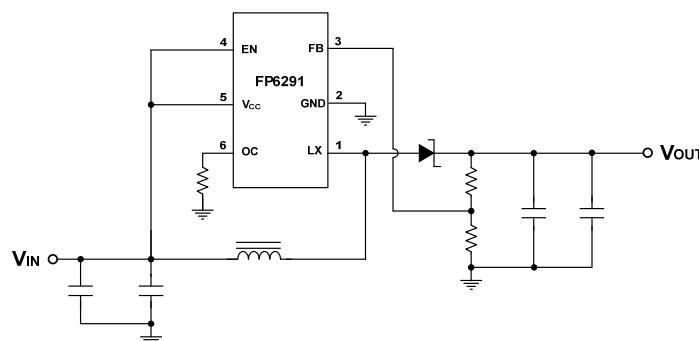

Function Block Diagram

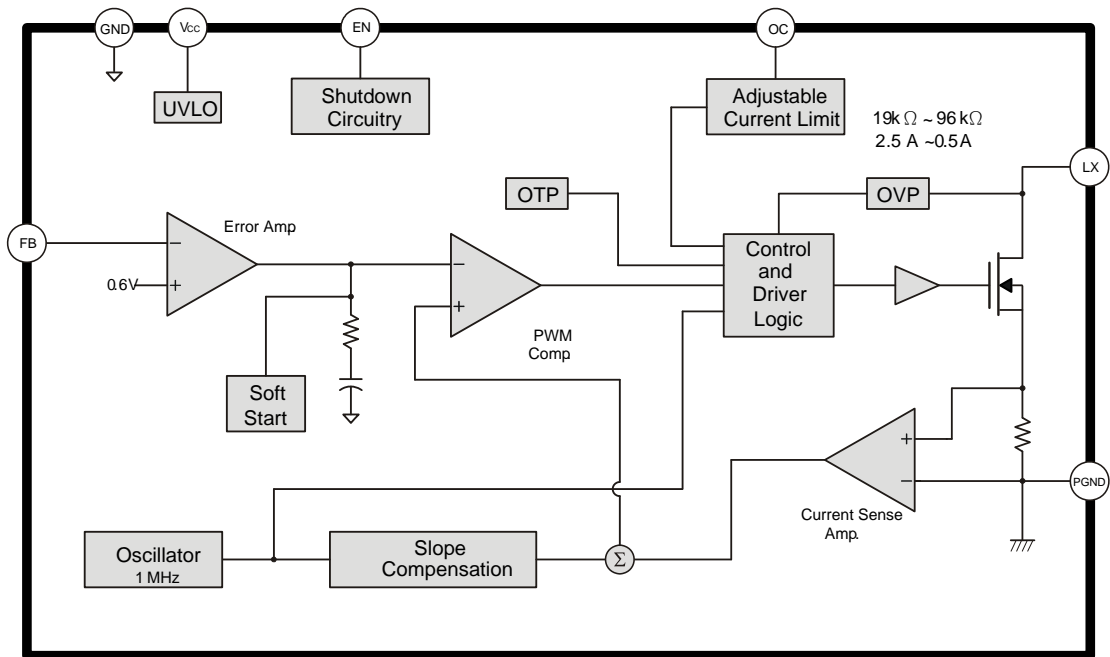

Pin Descriptions

SOT23-6L

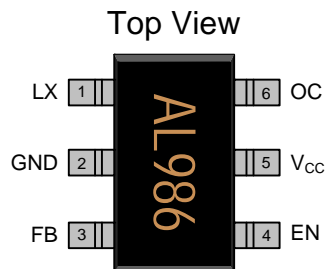

Name	No.	I / O	Description
LX	1	O	Power Switch Output
GND	2	P	IC Ground
FB	3	I	Error Amplifier Inverting Input
EN	4	I	Enable Control (Active High)
V _{CC}	5	P	IC Power Supply
OC	6	I	Adjustable Current Limit (Floating Available)

Marking Information

SOT23-6L

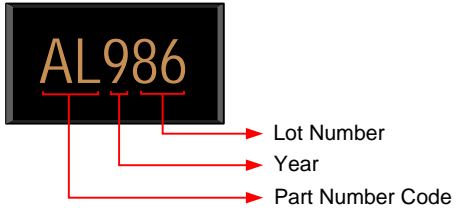

Lot Number: Wafer lot number's last two digits

For Example: 132386TB → 86

Year: Production year's last digit

Part Number Code: Part number identification code for this product. It should be always "AL".

Ordering Information

Part Number	Code	Operating Temperature	Package	MOQ	Description
FP6291LR-G1	AL	-40°C ~ 85°C	SOT23-6L	3000EA	Tape & Reel

Absolute Maximum Ratings

Parameter	Symbol	Conditions	Min.	Typ.	Max.	Unit
Supply Voltage	V_{CC}		0		6	V
LX Voltage	V_{LX}		0		16	V
EN,FB Voltage			0		6	V
Power Dissipation	P_D	SOT23-6L @ $T_A=25^\circ\text{C}$			455	mW
Thermal Resistance (Note1)	θ_{JA}	SOT23-6L			+220	$^\circ\text{C} / \text{W}$
Junction Temperature	T_J				+150	$^\circ\text{C}$
Operating Temperature	T_{OP}		-40		+85	$^\circ\text{C}$
Storage Temperature	T_{ST}		-65		+150	$^\circ\text{C}$
Lead Temperature		(soldering, 10 sec)			+260	$^\circ\text{C}$

Note1:

θ_{JA} is measured in the natural convection at $T_A=25^\circ\text{C}$ on a low effective thermal conductivity test board of JEDEC 51-3 thermal measurement standard.

IR Re-flow Soldering Curve

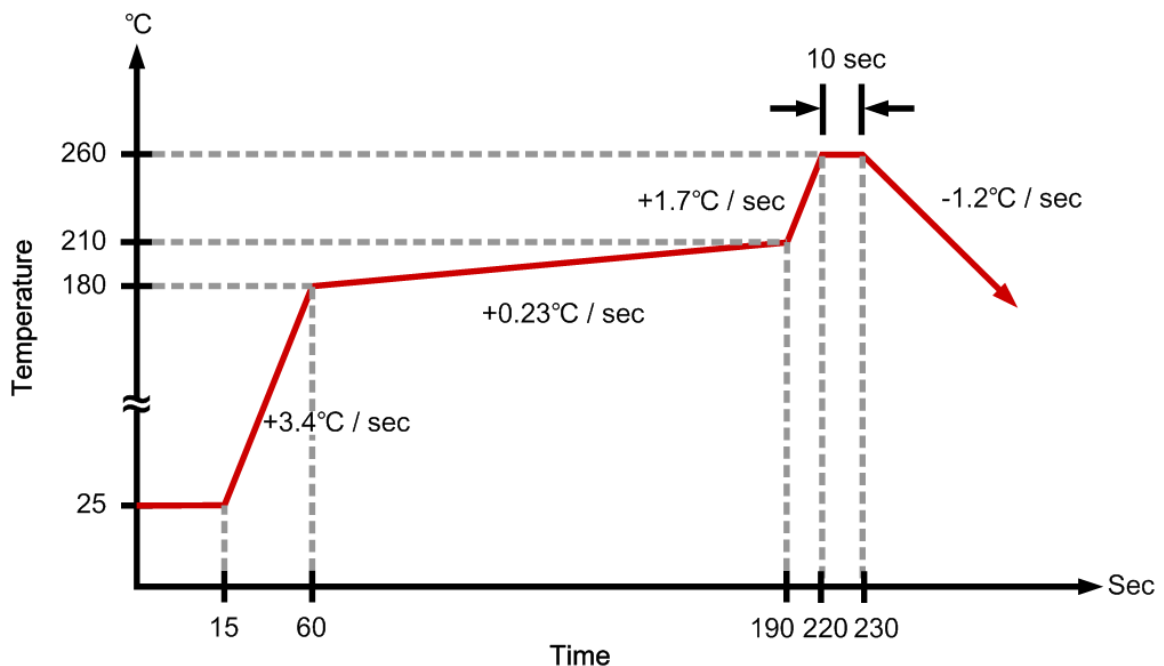

Recommended Operating Conditions

Parameter	Symbol	Conditions	Min.	Typ.	Max.	Unit
Supply Voltage	V _{IN}		2.6		5.5	V
Operating Temperature Range	T _A	Ambient Temperature	-40		+85	°C

DC Electrical Characteristics (V_{CC}=3.3V, T_A=25°C, unless otherwise specified)

Parameter	Symbol	Conditions	Min.	Typ.	Max.	Unit
System Supply Input						
Input Supply Range	V _{CC}		2.6		5.5	V
Under Voltage Lockout	V _{UVLO}			2.2		V
UVLO Hysteresis				0.1		V
Quiescent Current	I _{CC}	V _{FB} =0.66V, No switching		0.19		mA
Average Supply Current	I _{CC}	V _{FB} =0.55V, Switching		2.84		mA
Shutdown Supply Current	I _{CC}	V _{EN} =GND		0.1		μA
Oscillator						
Operation Frequency	F _{OSC}	V _{FB} =1.0V	0.8	1.0	1.2	MHz
Frequency Change with Voltage	Δf / ΔV	V _{CC} =2.6V to 5.5V		5		%
Maximum Duty Cycle	T _{DUTY}			90		%
Reference Voltage						
Reference Voltage	V _{REF}		0.588	0.6	0.612	V
Line Regulation		V _{CC} =2.6V ~ 5.5V		0.2		% / V
Enable Control						
Enable Voltage	V _{EN}		0.96			V
Shutdown Voltage	V _{EN}				0.6	V
MOSFET						
On Resistance of Driver	R _{DS (ON)}	I _{LX} =2A		0.2		Ω
Protection						
OCP Current	I _{OCP}			2.5		A
Adjustable OCP Current	I _{OCP}	With External Resistor : 19k~96k	0.5		2.5	A
OTP Temperature	T _{OTP}			+150		°C

Typical Operating Characteristics

($V_{CC}=3.3V$, $V_{OUT}=5V$, $T_A=25^{\circ}C$, unless otherwise noted)

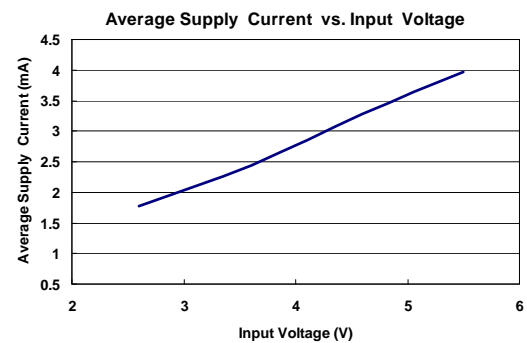
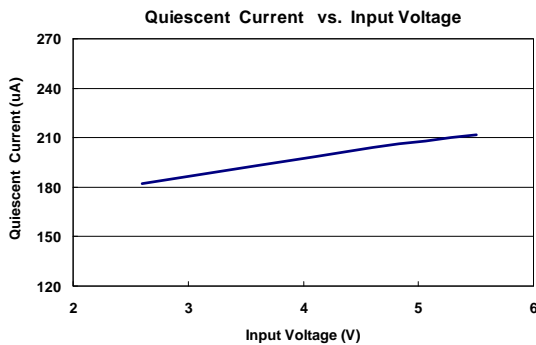
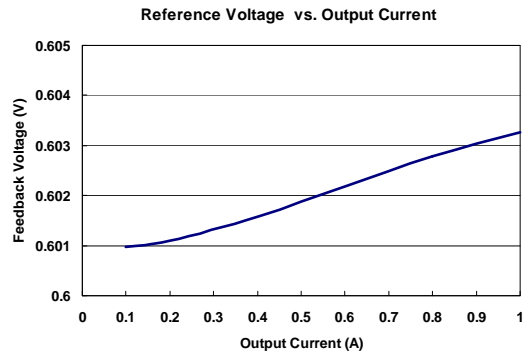
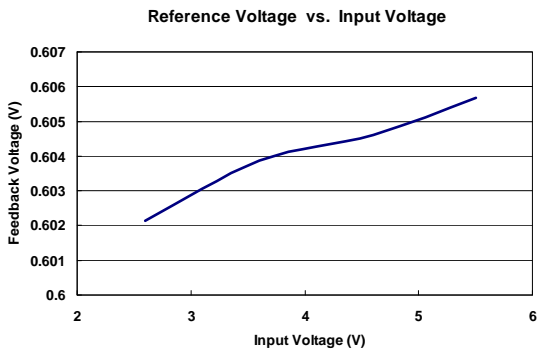
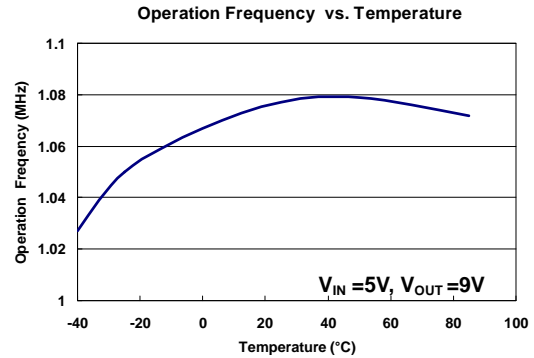
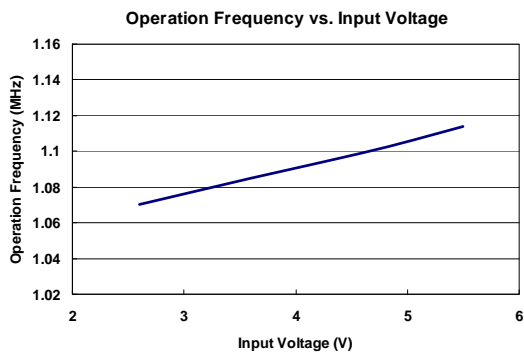
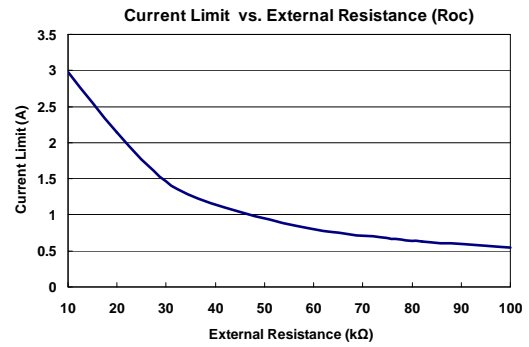
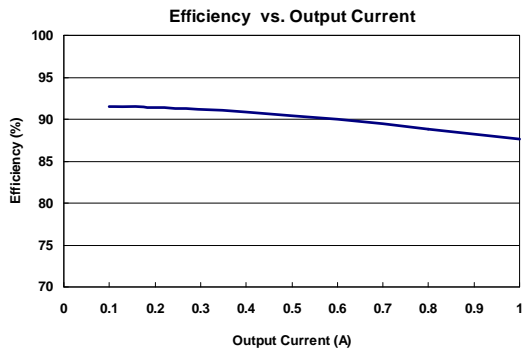

Function Description

Operation

The FP6291 is a current mode boost converter. The constant switching frequency is 1MHz and operates with pulse width modulation (PWM). Build-in 16V / 2.5A MOSFET provides a high output voltage. The control loop architecture is peak current mode control; therefore slope compensation circuit is added to the current signal to allow stable operation for duty cycles larger than 50%.

Soft Start Function

Soft start circuitry is integrated into FP6291 to avoid inrush current during power on. After the IC is enabled, the output of error amplifier is clamped by the internal soft-start function, which causes PWM pulse width increasing slowly and thus reducing input surge current.

Current Limit Program

A resistor between OC and GND pin programs peak switch current. The resistor value should be between 19k and 96k. The current limit will be set from 2.5A to 0.5A. Keep traces at this pin as short as possible. Do not put capacitance at this pin. To set the over current trip point according to the following equation:

$$I_{OCP} = \frac{48000}{R3}$$

Over Temperature Protection (OTP)

FP6291 will turn off the power MOSFET automatically when the internal junction temperature is over 150°C. The power MOSFET wake up when the junction temperature drops 30°C under the OTP threshold temperature.

Over Voltage Protection (OVP)

In some condition, the resistive divider may be unconnected, which will cause PWM signal to operate with maximum duty cycle and output voltage is boosted higher and higher. The power MOSFET will be turned off immediately, when the output voltage exceeds the OVP threshold level. The FP6291's OVP threshold is 16V.

Application Information

Inductor Selection

Inductance value is decided based on different condition. 3.3uH to 4.7μH inductor value is recommended for general application circuit. There are three important inductor specifications, DC resistance, saturation current and core loss. Low DC resistance has better power efficiency. Also, it avoid inductor saturation which will cause circuit system unstable and lower core loss at 1 MHz.

Capacitor Selection

The output capacitor is required to maintain the DC voltage. Low ESR capacitors are preferred to reduce the output voltage ripple. Ceramic capacitor of X5R and X7R are recommended, which have low equivalent series resistance (ESR) and wider operation temperature range.

Diode Selection

Schottky diodes with fast recovery times and low forward voltages are recommended. Ensure the diode average and peak current rating exceed the average output current and peak inductor current. In addition, the diode's reverse breakdown voltage must exceed the output voltage.

Output Voltage Programming

The output voltage is set by a resistive voltage divider from the output voltage to FB. The output voltage is:

$$V_{OUT} = 0.6V \left(1 + \frac{R1}{R2} \right)$$

Layout Considerations

1. The power traces, consisting of the GND trace, the LX trace and the V_{CC} trace should be kept short, direct and wide.
2. LX · L and D switching node, wide and short trace to reduce EMI.
3. Place C_{IN} near V_{CC} pin as closely as possible to maintain input voltage steady and filter out the pulsing input current.
4. The resistive divider R1 and R2 must be connected to FB pin directly as closely as possible.
5. FB is a sensitive node. Please keep it away from switching node, LX.
6. The GND of the IC, C_{IN} and C_{OUT} should be connected close together directly to a ground plane.

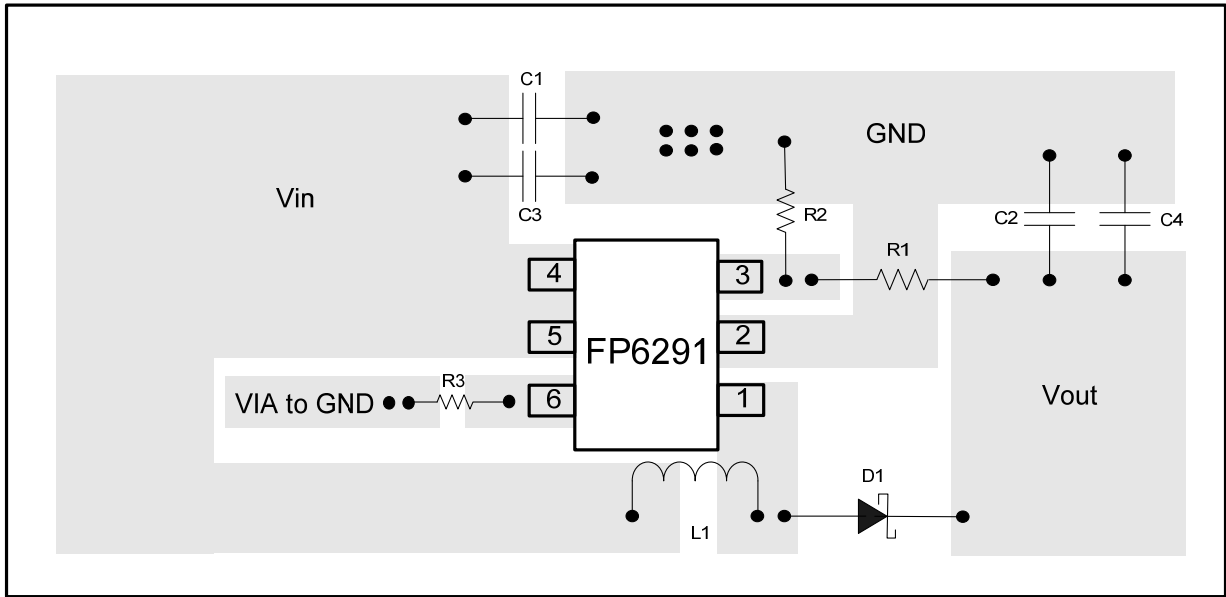

Suggested Layout

Typical Application

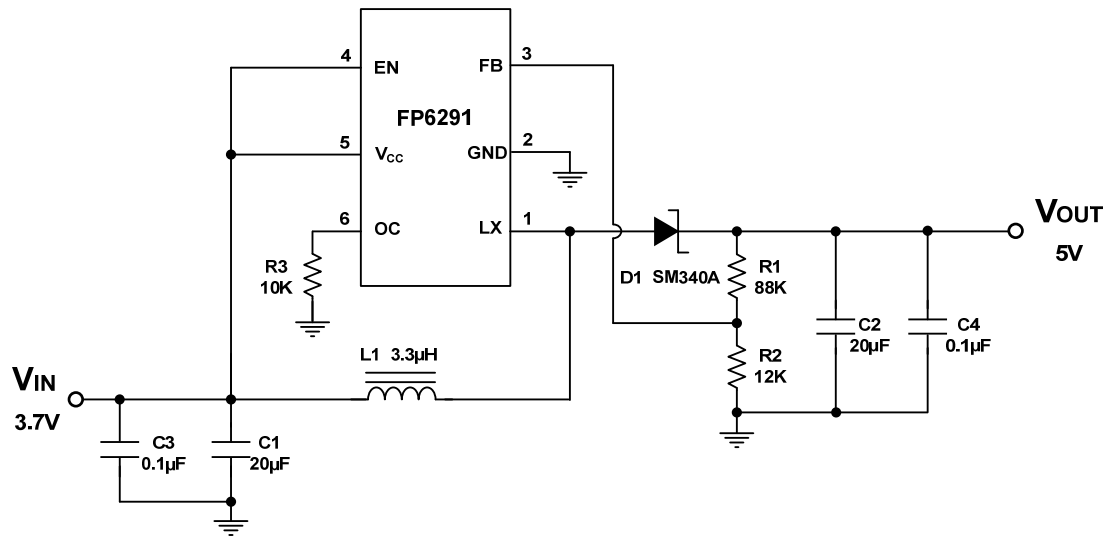

Note: Don't pull the Vout back to the FP6291's Vcc pin. When the system receives the noise, it will lead to Vout ripple too high and over the absolute maximum rating of the Vcc pin.

Package Outline

SOT23-6L

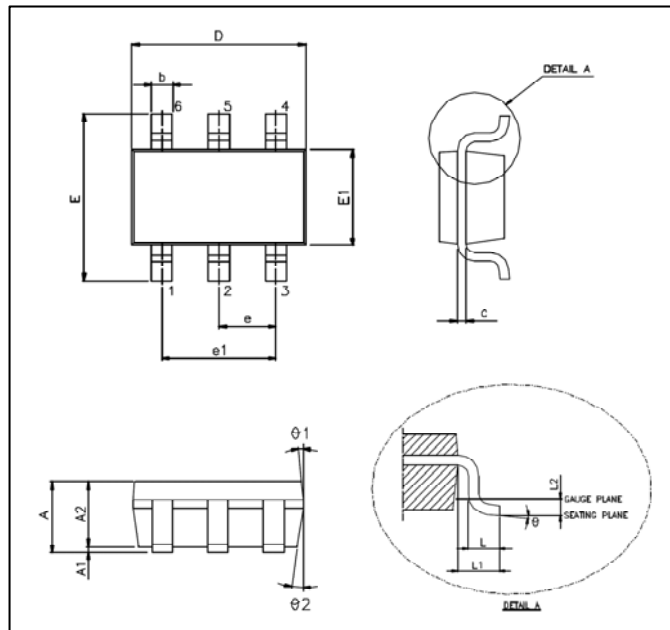

Unit: mm

Symbols	Min. (mm)	Max. (mm)
A	1.050	1.450
A1	0.050	0.150
A2	0.900	1.300
b	0.300	0.500
c	0.080	0.220
D	2.900 BSC	
E	2.800 BSC	
E1	1.600 BSC	
e	0.950 BSC	
e1	1.900 BSC	
L	0.300	0.600
L1	0.600 REF	
L2	0.250 BSC	
θ°	0°	8°
$\theta1^\circ$	3°	7°
$\theta2^\circ$	6°	15°

Note:

1. Package dimensions are in compliance with JEDEC outline: MO-178 AB.
2. Dimension "D" does not include molding flash, protrusions or gate burrs.
3. Dimension "E1" does not include inter-lead flash or protrusions.