Synchronous Buck DC/DC Converter IA3406

Features

- Up to 95% Efficiency
- Current mode operation for excellent line and load transient response
- Low quiescent current: 230 μ A
- Low Switch on Resistance $R_{DS(ON)}$, Internal Switch: 0.35 Ω
- Output voltage: 5.5V~0.6V
- Automatic PWM/PFM mode switching
- No Schottky diode required
- 1.4MHz fixed frequency switching
- Short-Circuit protection
- Shutdown quiescent current: < 1 μ A
- Low profile SOT-23-5 package (lead-free packaging is now available)

Application

- Digital cameras and MP3
- Palmtop computers / PDAs
- Cellular phones
- Wireless handsets and DSL modems
- PC cards
- Portable media players

Description

The IA3406 is high efficiency synchronous, PWM step-down DC/DC converters working under an input voltage range of 2.5V to 5.5V. This feature makes the IA3406 suitable for single Li-Ion battery-powered applications. Automatic PWM/PFM mode switching saves power at light load. 100% duty cycle capability extends battery life in portable devices, while the quiescent current is 230 μ A with no load, and drops to < 1 μ A in shutdown.

The internal synchronous switch is desired to increase efficiency without an external Schottky diode. The 1.4 MHz fixed switching frequency allows the using of tiny, low profile inductors and ceramic capacitors, which minimized overall solution footprint.

The IA3406 converters are available in the industry standard SOT-23-5 power packages (or upon request).

Order Information

IA3406 - ① ② :

SYMBOL	DESCRIPTION
①	Denotes Output voltage: B : 1.5V Output; C : 1.8V Output; G:3.3V Output;A : Adjustable Output
②	Denotes Package Types: E: SOT-23-5

Typical Applications

FIXED OUTPUT VOLTAGE

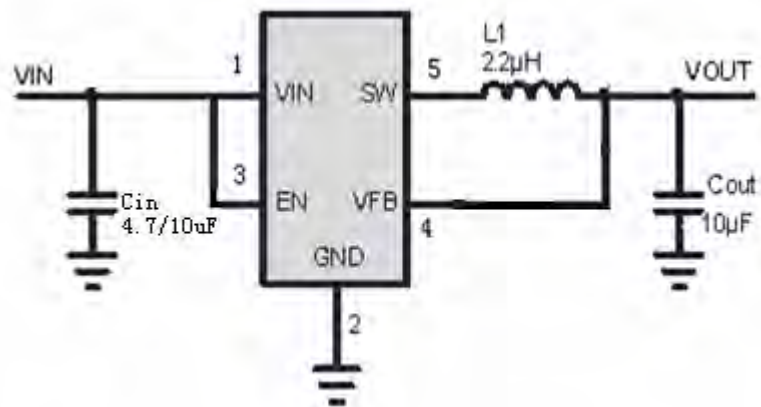

MODEL	VOUT (V)	VIN (V)	MARK
IA3406-KE	1.2	2.2~5.5	F1CE
IA3406-BE	1.5	2.4~5.5	F1F8
IA3406-CE	1.8	2.5~5.5	F1LE
IA3406-GE	3.3	3.4~5.5	F1F3

ADJUSTABLE OUTPUT VOLTAGE

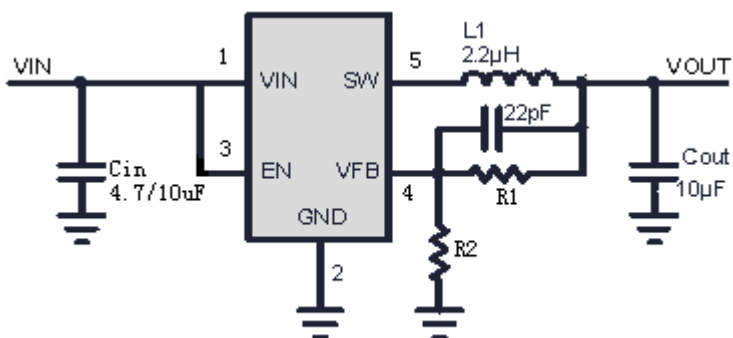

MODEL	VOUT (V)	MARK
IA3406-AE	Adjustable Output Voltage	F1L9

THE DEVICE RECOMMENDED

V _{OUT} (V)	CAPACITOR SIZE/TYPE		RESISTOR SIZE/TYPE		INDUCTOR SIZE/TYPE (μ H)
	C _{IN} (μ F)	C _{OUT} (μ F)	R ₂ (K Ω)	R ₁ (K Ω)	
1.2	4.7/10(0805)	10(0805)	100 (0805)	100 (0805)	CKH4B28-2.2 μ H
1.5	4.7/10(0805)	10(0805)	1000(0805)	620(0805)	CKH4B28-2.2 μ H
1.8	4.7/10(0805)	10(0805)	200(0805)	100(0805)	CKH4B28-2.2 μ H
3.3	4.7/10(0805)	10(0805)	330(0805)	75(0805)	CKH4B28-2.2 μ H

Pin Assignment

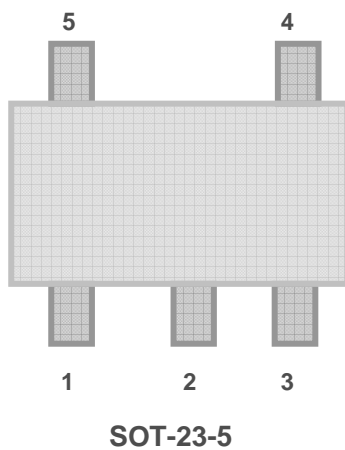

PIN NUMBER SOT-23- 5	PIN NAME	FUNCTION
1	V _{IN}	Input
2	GND	Ground
3	EN	ON/OFF Control (High Enable)
4	V _{OUT}	Output
5	SW	Switch Output

Functional Diagram

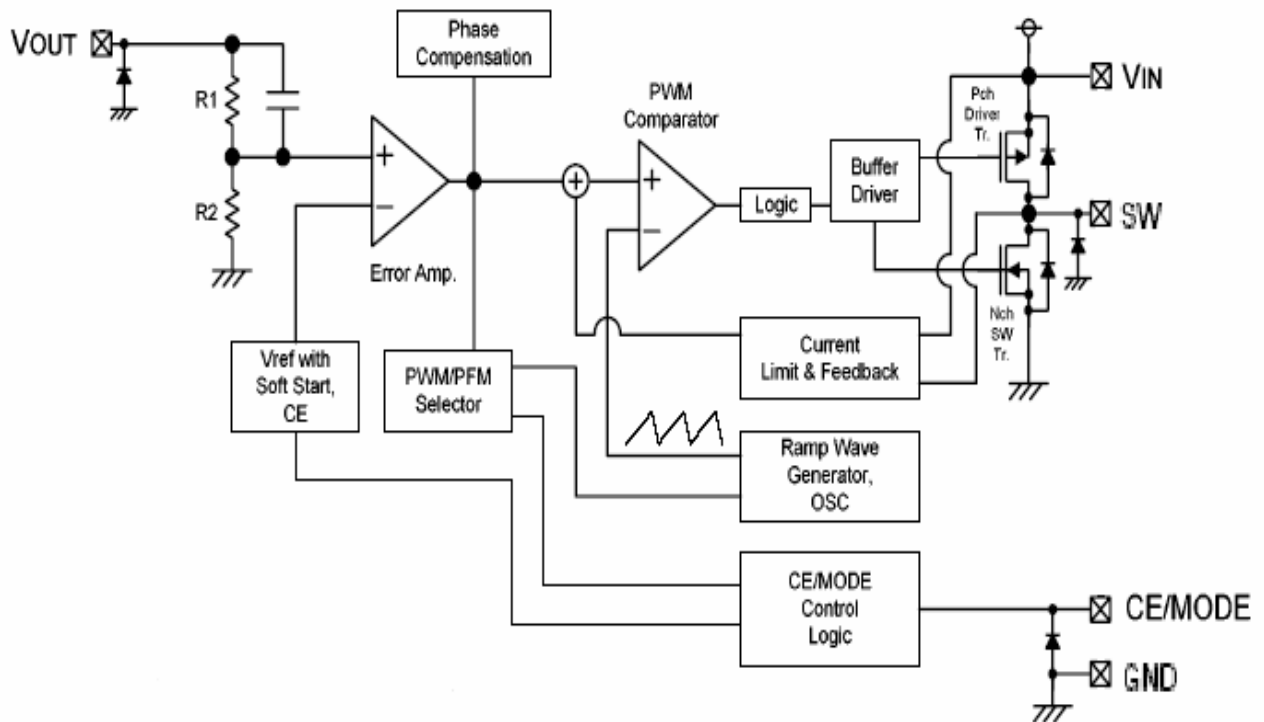

Absolute Maximum Ratings

- Power Dissipation.....Internally limited
- V_{IN} - 0.3 V ~ + 6 V
- $V_{ON/OFF}$ - 0.3 V ~ ($V_{IN} + 0.3$) V
- V_{SW} - 0.3 V ~ ($V_{IN} + 0.3$) V
- V_{FB}- 0.3 V ~ + 6 V
- I_{SW} 1.3A
- Operating Temperature Range- 40°C ~ + 85°C
- Lead Temperature (Soldering 10 sec.)+ 300°C
- Storage Temperature Range- 65°C ~ + 150°C
- Junction Temperature+ 125°C

Electrical Characteristics

Operating Conditions: $T_A=25^{\circ}\text{C}$, $V_{IN}=3.6\text{V}$ unless otherwise specified.

SYMBOL	PARAMETER	CONDITIONS	MIN	TYP	MAX	UNITS
V_{OUT}	Output Voltage	$I_{OUT} = 100\text{mA}$	1.75	1.80	1.85	V
V_{IN}	Input Voltage Range		2.5		5.5	V
V_{FB}	Regulated Voltage	$T_A = 25^{\circ}\text{C}$	0.5880	0.6	0.6120	V
I_{FB}	Feedback Current				± 30	nA
ΔV_{FB}	V_{REF}	$V_{IN}=2.5\text{V}\sim 5.5\text{V}$		0.03	0.4	%/V
F_{OSC}	Oscillator Frequency	$V_{FB} = 0.6\text{V}$ or $V_{OUT} = 100\%$	1.1	1.4	1.7	MHz
I_Q	Quiescent Current	$V_{FB} = 0.5\text{V}$ or $V_{OUT} = 90\%$, $I_{LOAD} = 0\text{A}$		230	300	μA
I_S	Shutdown Current	$V_{EN} = 0\text{V}$, $V_{IN} = 4.2\text{V}$		0.1	1	μA
I_{PK}	Peak Inductor Current	$V_{IN} = 3\text{V}$, $V_{FB} = 0.5\text{V}$ or $V_{OUT} = 90\%$, Duty Cycle < 35%	0.75	0.9	1	A
R_{PFET}	$R_{DS(ON)}$ of P-Channel FET	$I_{SW} = 100\text{mA}$		0.4	0.5	Ω
R_{NFET}	$R_{DS(ON)}$ of N-Channel FET	$I_{SW} = -100\text{mA}$		0.35	0.45	Ω
$EFFI^*$	Efficiency	When connected to ext. components $V_{IN}=EN=3.6\text{V}$, $I_{OUT}=100\text{mA}$		93		%
ΔV_{OUT}	V_{OUT} Line Regulation	$V_{IN}=2.5\text{V}\sim 5.5\text{V}$		0.03	0.3	%/V
$V_{LOADREG}$	V_{OUT} Load Regulation			0.33		%

* $EFFI = [(\text{Output Voltage} \times \text{Output Current}) / (\text{Input Voltage} \times \text{Input Current})] \times 100\%$

Typical Performance Characteristics

VOUT=1.8V

VOUT=2.5V

CONVERSION EFFICIENCY

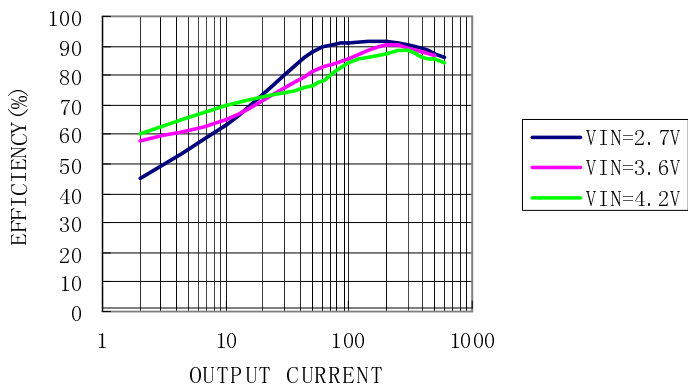

CONVERSION EFFICIENCY

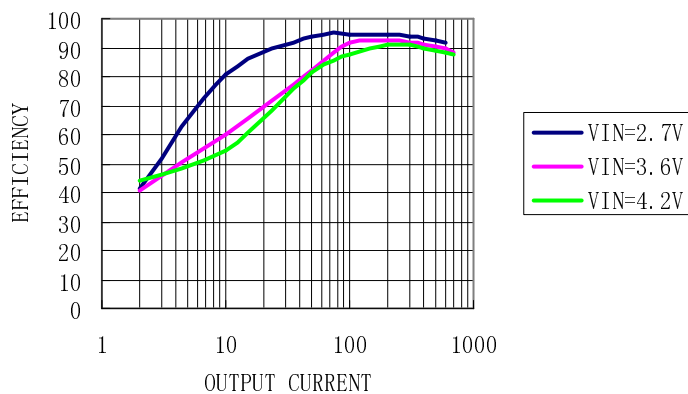

VOUT
100mV/DIV
AC COUPLED

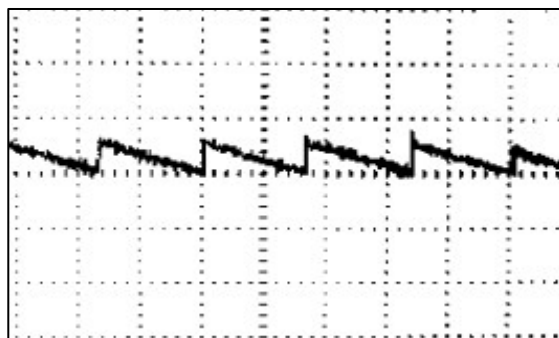

VIN=3.6V
VOUT=1.8V
ILOAD=0mA

2ms/DIV

VOUT
10mV/DIV
AC COUPLED

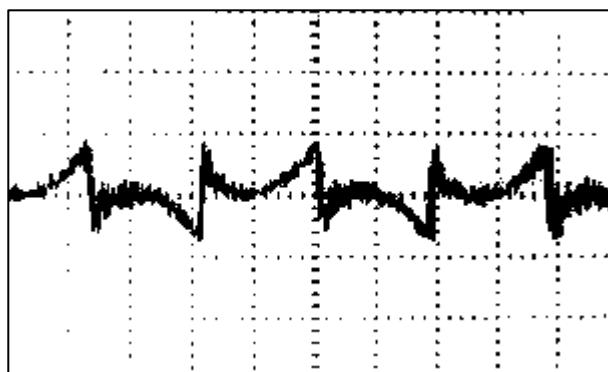

VIN=3.6V
VOUT=1.8V
ILOAD=200mA

200ns/DIV

Typical Performance Characteristics

Start-up from shutdown

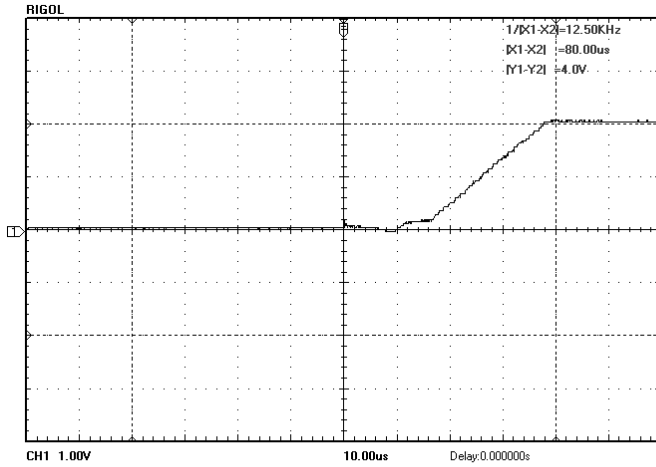

Quiescent Supply Current vs. Supply Voltage

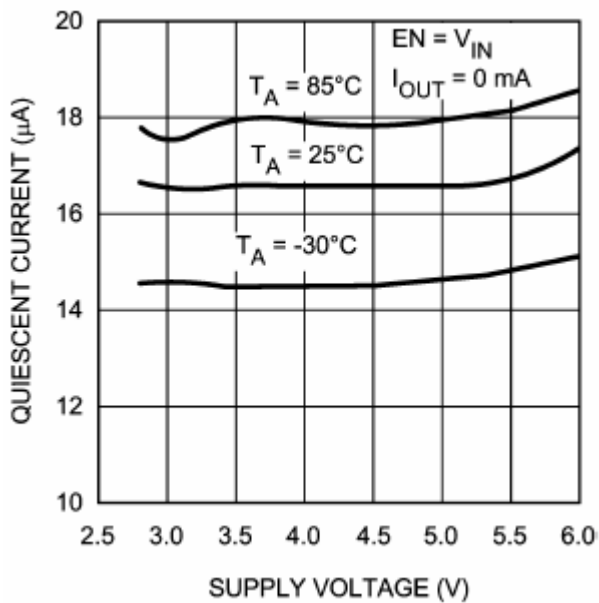

Feed back Bias Current vs. Temp

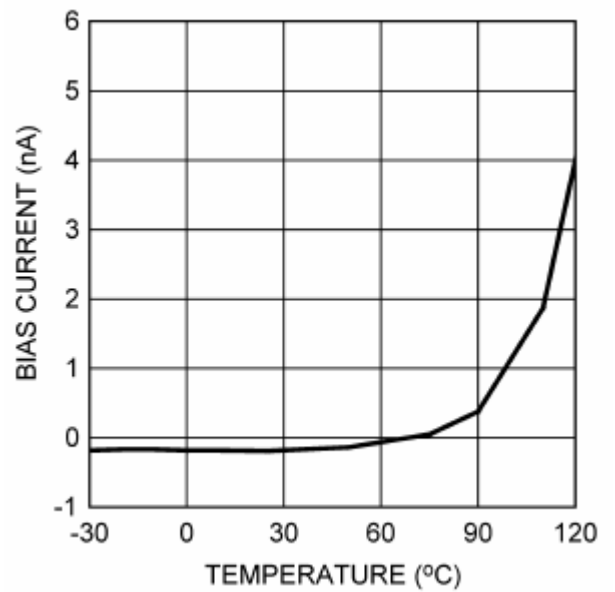

Typical Performance Characteristics

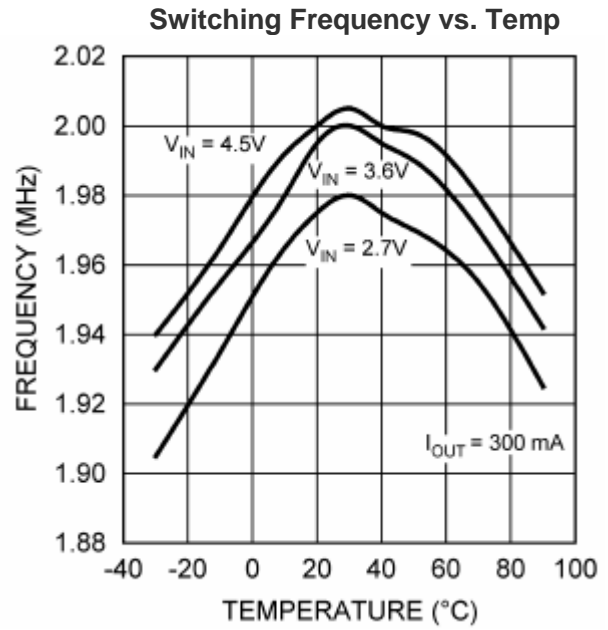
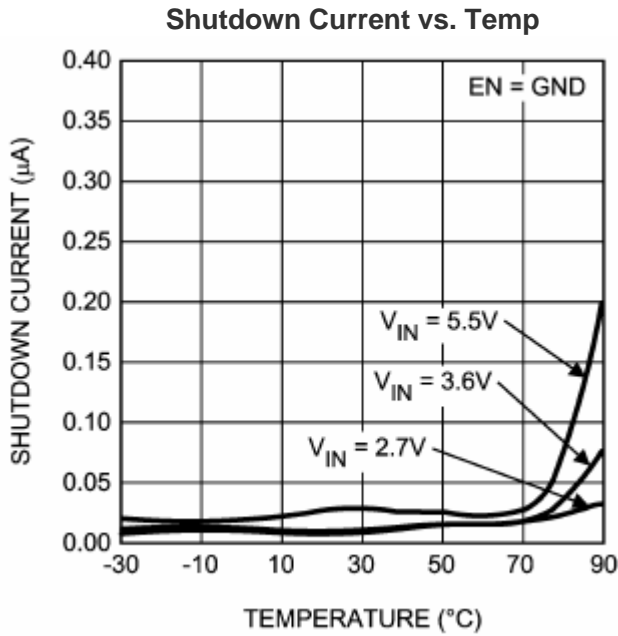

Rds(on) vs. Temp

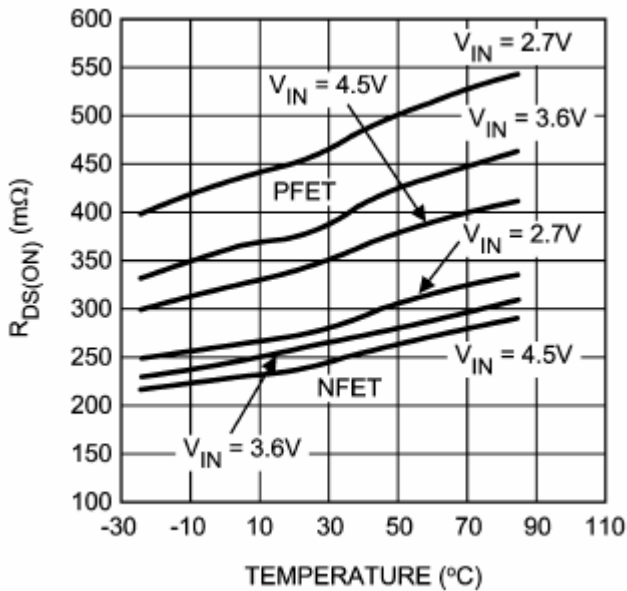

Open/Closed Loop Current Limit vs. Temp

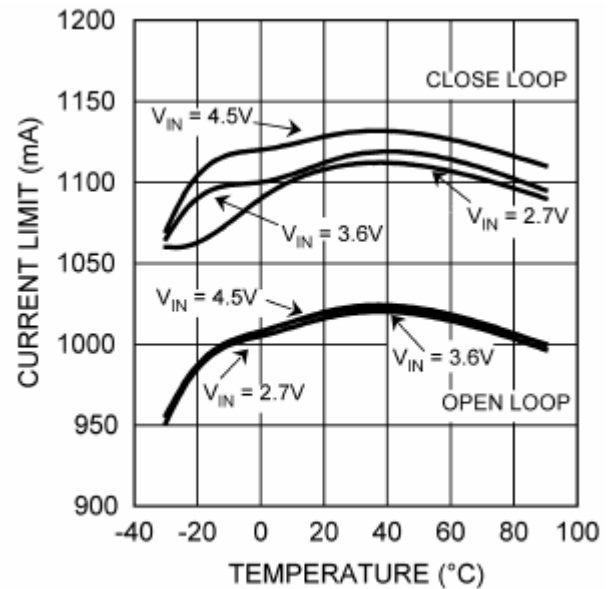

Application Information

PIN ASSIGNMENT

V_{IN} (Pin 1): Main Supply Pin. Must be closely decoupled to GND, Pin 2, with a 2.2μF or greater ceramic capacitor.

GND (Pin 2): Ground Pin.

EN (Pin 3): En Control Input. Forcing this pin above 1.5V enables the part. Forcing this pin below 0.3V shutsdown the device. In shutdown, all functions are disabled drawing <1μA supply current. Do not leave EN floating.

V_{OUT} (Pin 4) (IA3406-BE/IA3406-CE): Output Voltage Feedback Pin. An internal resistive divider divides the output voltage down for comparison to the internal reference voltage.

SW (Pin 5): Switch Node Connection to Inductor. This pin connects to the drains of the internal main and synchronous power MOSFET switches.

V_{FB} (Pin 4) (IA3406-AE): Feedback Pin. Receives the feedback voltage from an external resistive divider across the output. In the adjustable version, the output voltage is set by a resistive divider according to the following formula: $V_{OUT} = 0.6V \cdot [1 + (R1/R2)]$.

INDUCTOR SELECTION

For most applications, the value of the inductor will fall in the range of 1μH to 4.7μH. Its value is chosen based on the desired ripple current. Large value inductors lower ripple current and small value inductors result in higher ripple currents. Higher V_{IN} or V_{OUT} also increases the ripple current as shown in equation 1. A reasonable starting point for setting ripple current is $\Delta I_L = 240\text{mA}$ (40% of 600mA).

$$\Delta I_L = \frac{1}{(f)(L)} V_{OUT} \left(1 - \frac{V_{OUT}}{V_{IN}} \right)$$

The DC current rating of the inductor should be at least equal to the maximum load current plus half the ripple current to prevent core saturation. Thus, a 720mA rated inductor should be enough for

most applications (600mA + 120mA). For better efficiency, choose a low DC-resistance inductor. Different core materials and shapes will change the size/current and price/current relationship of an inductor. Toroid or shielded pot cores in ferrite or permalloy materials are small and don't radiate much energy, but generally cost more than powdered iron core inductors with similar electrical characteristics. The choice of which style inductor to use often depends more on the price vs size requirements and any radiated field/EMI requirements than on what the IA3406 requires to operate. Table 1 shows some typical surface mount inductors that work well in IA3406 applications.

Table 1. Recommended Inductors

PART	L (μH)	MAX DCR mΩ	MAX DC CURRENT (A)	SIZE W × L × H (mm ³)	VENDOR
CDRH3D16	2.2	75	1.20	3.8 × 3.8 × 1.8	Sumida
CDH3B16	2.2	70	1.20	4.0 × 4.0 × 1.8	Ceaiya

OUTPUT AND INPUT CAPACITOR SELECTION

In continuous mode, the source current of the top MOSFET is a square wave of duty cycle V_{OUT}/V_{IN} . To prevent large voltage transients, a low ESR input capacitor sized for the maximum RMS current must be used. The maximum RMS capacitor current is given by:

$$C_{IN} \text{ required } I_{RMS} \cong I_{OMAX} \frac{[V_{OUT}(V_{IN} - V_{OUT})]^{1/2}}{V_{IN}}$$

This formula has a maximum at $V_{IN} = 2V_{OUT}$, where $I_{RMS} = I_{OUT}/2$. This simple worst-case condition is commonly used for design because even significant deviations do not offer much relief. Note that the capacitor manufacturer's ripple current ratings are often based on 2000 hours of life. This makes it advisable to further derate the capacitor, or choose a capacitor rated at a higher temperature than required. Always consult the manufacturer if there is any question.

The selection of C_{OUT} is driven by the required effective series resistance (ESR).

Typically, once the ESR requirement for C_{OUT} has been met, the RMS current rating generally far exceeds the $I_{RIPPLE(P-P)}$ requirement. The output ripple ΔV_{OUT} is determined by:

$$\Delta V_{OUT} \cong \Delta I_L \left(ESR + \frac{1}{8fC_{OUT}} \right)$$

where f = operating frequency, C_{OUT} = output capacitance and ΔI_L = ripple current in the inductor. For a fixed output voltage, the output ripple is highest at maximum input voltage since ΔI_L increases with input voltage.

Aluminum electrolytic and dry tantalum capacitors are both available in surface mount configurations. In the case of tantalum, it is critical that the capacitors are surge tested for use in switching power supplies. An excellent choice is the AVX TPS series of surface mount tantalum. These are specially constructed and tested for low ESR so they give the lowest ESR for a given volume. Other capacitor types include Sanyo POSCAP, Kemet T510 and T495 series, and Sprague 593D and 595D series. Consult the manufacturer for other specific recommendations.

Packaging Information

SOT-23-5 Package Outline Dimension

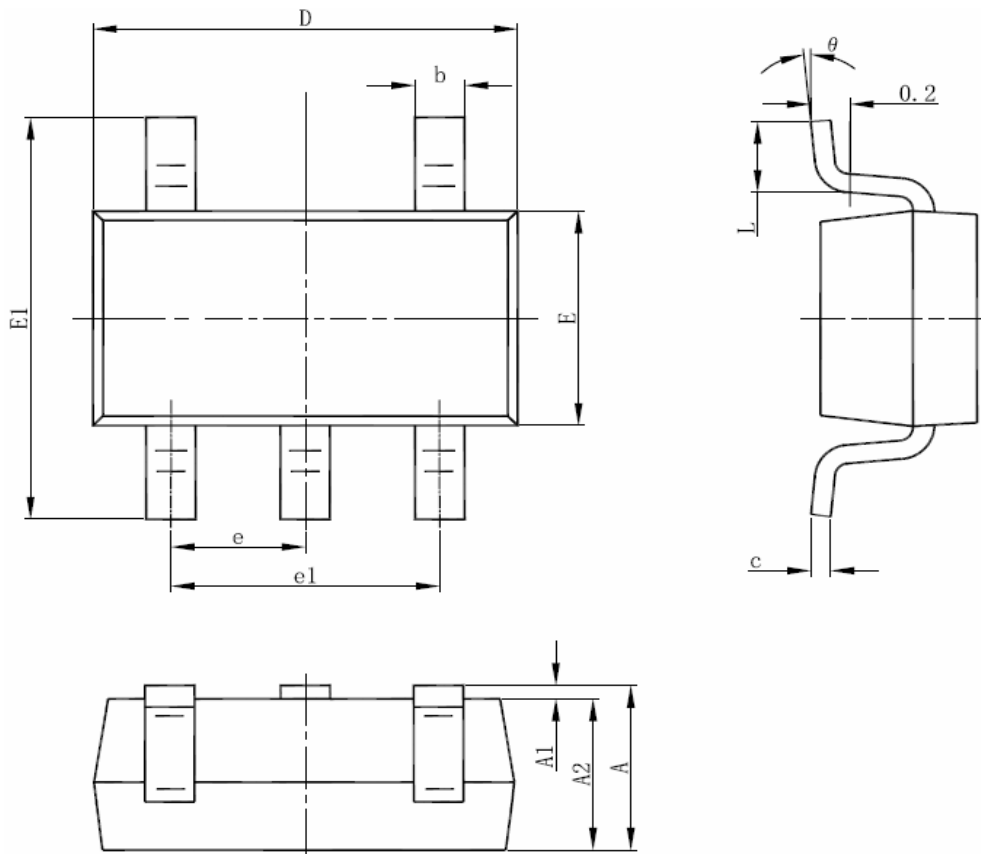

Symbol	Dimensions In Millimeters		Dimensions In Inches	
	Min	Max	Min	Max
A	1.050	1.250	0.041	0.049
A1	0.000	0.100	0.000	0.004
A2	1.050	1.150	0.041	0.045
b	0.300	0.500	0.012	0.020
c	0.100	0.200	0.004	0.008
D	2.820	3.020	0.111	0.119
E	1.500	1.700	0.059	0.067
E1	2.650	2.950	0.104	0.116
e	0.950(BSC)		0.037(BSC)	
e1	1.800	2.000	0.071	0.079
L	0.300	0.600	0.012	0.024
θ	0°	8°	0°	8°