

Parameters Subject to Change Without Notice

DESCRIPTION

The JW[®]3655 is a buck boost converter targets HVDC fast charging system.

The JW3655 supports 1 to 3 cells Li-ion battery, the full charge voltage and charge current can be programmed through external resistor.

The JW3655 implements the Buck Boost converter with an H-bridge. The integrated low R_{DS(on)} MOSFET minimizes physical footprint, maximizes charge efficiency. Built-in loop compensation simplifies the circuit and design. PFM is engaged to maintain high efficiency at light load current.

JW3655 guarantees robustness with thermal protection and battery under voltage lockout.

Company's Logo is Protected, "JW" and "JOULWATT" are Registered Trademarks of JoulWatt technology Inc.

FEATURES

- Integrate low R_{DS(on)} power MOSFET
- Wide input range: 4.2V-16.0V, Support 1 to 3 cells battery charge
- Full charge voltage: 1.2V-16.0V through external resistor or selectable by BATFB pin JW3655 (4.2V/cell)/JW3655-1 (4.35V/cell)
- High efficiency buck-boost transition
- 450kHz Switching frequency
- Programmable charge current, up to 3A
- Quiescent current: <60uA
- Integrate battery short protection
- Integrate thermal protection
- QFN3*4 package

APPLICATIONS

- Power bank systems
- Battery and supercapacitor charging
- USB power delivery
- Industrial applications
- Automotive systems

TYPICAL APPLICATION

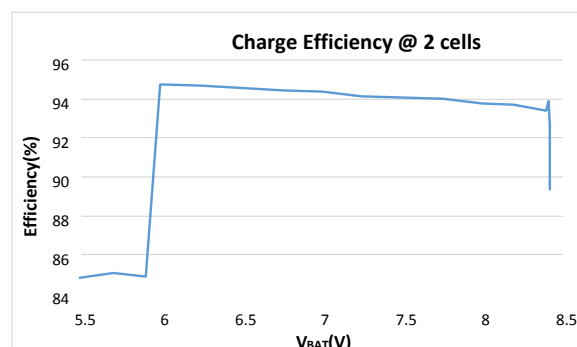
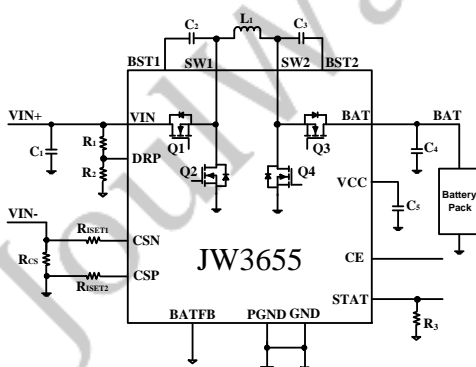

ORDER INFORMATION

TAPE AND REEL ¹⁾	PACKAGE	TOP MARKING ²⁾
JW3655QFNE#TRPBF	QFN3X4-15	JW3655 XXXXXX
JW3655-1QFNE#TRPBF	QFN3X4-15	JW3655-1 XXXXXX

Notes:



2) Line 1 of top marking means Part No., and the line 2 of top marking means Date Code.

PIN CONFIGURATION

TOP VIEW

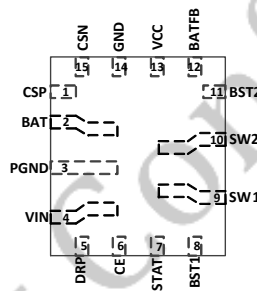

ABSOLUTE MAXIMUM RATING¹⁾

VIN ,BAT, SW1, SW2 Pin	-0.3V to 20V
BST1-SW1, BST2-SW2	-0.3V to 6.5V
All Other Pins	-0.3V to 6.5V
Junction Temperature ²⁾³⁾	150°C
Lead Temperature	260°C
Storage Temperature	-65°C to +150°C
ESD Susceptibility (Human Body Model)	2kV

RECOMMENDED OPERATING CONDITIONS

Input Voltage VIN1.2V to 16V
 Battery Voltage VBAT3.0V to 16V
 Operation Junction Temp (T_J)-40°C to +125°C

THERMAL PERFORMANCE⁴⁾ $\theta_{JA} \theta_{JC}$

QFN3X4-15.....48.....11°C/W

Note:

- 1) Exceeding these ratings may damage the device.
- 2) The JW3655 guarantees robust performance from -40°C to 150°C junction temperature. The junction temperature range specification is assured by design, characterization and correlation with statistical process controls.
- 3) The JW3655 includes thermal protection that is intended to protect the device in overload conditions. Thermal protection is active when junction temperature exceeds the maximum operating junction temperature. Continuous operation over the specified absolute maximum operating junction temperature may damage the device.
- 4) Measured on JESD51-7, 4-layer PCB.

JoulWatt Confidential

ELECTRICAL CHARATERISTICS

<i>VIN=5V, TA=25 °C, unless otherwise stated</i>						
Item	Symbol	Condition	Min.	Typ.	Max.	Units
Power supply						
VBAT voltage range	V _{BAT}		3.0		16	V
VCC output voltage	V _{CC}		4.7	5.0	5.3	V
VCC output current limit	I _{VCC}	V _{CC} >2.7V		50		mA
Supply current in shut-down mode	I _Q	V _{BAT} =4V, EN=0V	30		60	µA
Controller						
Switch frequency	F _{sw} ⁵⁾		350	450	450	kHz
Switch minimum off time	T _{off_min} ⁵⁾		80	100	120	ns
CE Logic HIGH	V _{ENH}	V _{BAT} =8V			2.5	V
CE Logic LOW	V _{ENL}	V _{BAT} =8V	1.6			V
Bucktop switch on-resistance	R _{dsbkTG} ⁵⁾			20	28	mΩ
Buck bottom switch on-resistance	R _{dsbkBG} ⁵⁾			20	28	mΩ
Boost top switch on-resistance	R _{dsbstG} ⁵⁾			20	28	mΩ
Boost bottom switch on-resistance	R _{dsbstBG} ⁵⁾			20	28	mΩ
Charge						
Floating BAT Voltage	V _{CV}	V _{BATFB} =GND, JW3655	8.358	8.4	8.442	V
		V _{BATFB} =GND, JW3655-1	8.656	8.7	8.743	V
		Set by divider resistor	3.0	-	16	V
BAT feedback voltage	V _{BATFB}	External resistor divider	1.191	1.2	1.212	V
BAT Recharge threshold	V _{REC}	V _{BATFB} = GND	8.118	8.2	8.282	V
BAT recharge feedback threshold	V _{RECFB}	JW3655	1.159	1.171	1.183	V
		JW3655-1	1.120	1.131	1.142	V
CC mode charge current	I _{CC}	R _{CS} =10mΩ, R _{ISSET1} =2K R _{ISSET2} =1.5K	1.92	2	2.08	A
Charge termination current	I _{TER}	R _{CS} =10mΩ, R _{ISSET1} =2K R _{ISSET2} =1.5K	100	200	300	mA
Battery full charge deglitch time	T _{FULL}	I _{CC} < I _{TER}		25		s
Trickle mode charge current	I _{TRI}	R _{CS} =10mΩ, R _{ISSET1} =2K R _{ISSET2} =1.5K	100	200	300	mA
Trickle mode battery threshold	V _{TRI}	V _{BATFB} = GND	5.9	6.0	6.1	V
Trickle mode feedback threshold	V _{TRIFB}	JW3655		0.857		V
		JW3655-1		0.828		V
Trickle charge time-out duration	T _{TRI}		50	55	60	min
VIN UVP threshold	V _{IN_UVP}	VIN rising	4.0	4.2	4.3	V

		VIN falling	3.8	4.0	4.1	V
VIN delay to start charging	$t_{\text{chg_delay}}$			150		ms
VIN droop voltage to foldback charge current	V_{DRP}	R1=100K Ω	320	370	420	mV
Battery current sensing ratio	K_{RATIO}	R _{CS} =10m Ω , R _{ISET1} =2K R _{ISET2} =1.5K		3		$\mu\text{A/A}$
Protection						
Thermal shutdown threshold ⁵⁾	$T_{\text{SHUT}}^{5)}$			150		$^{\circ}\text{C}$
Thermal recovery threshold ⁵⁾	$T_{\text{REC}}^{5)}$			130		$^{\circ}\text{C}$

Notes:

5) Guaranteed by design.

JoulWatt Confidential

PIN DESCRIPTION

Pin No.	Name	Description
1	CSP	Positive terminal of battery charge current sense.
2	BAT	Battery positive terminal.
3	PGND	Power Ground.
4	VIN	Main supply pin, connect to adaptor.
5	DRP	VIN droop allowance program pin.
6	CE	Charge enable pin, a logic High on this pin will enable charge.
7	STAT	This is a multi-purpose Pin. When charge enabled, in the CC charge mode, the pin source current is 6 μ A. In the full charge mode, the pin is pulled to high. And the pin also as Fault state output pin, asserted during over temperature or trickle charge time out conditions.
8	BST1	VIN side bootstrap supply pin for top switch. 0.1 μ F capacitor is connected between BST1 and SW1 pins.
9	SW1	VIN side power switching node. connect to SW2 with inductor
10	SW2	BAT side power switching node.
11	BST2	BAT side bootstrap supply pin for top switch. 0.1 μ F capacitor is connected between BST2 and SW2 pins.
12	BATFB	Battery float voltage configuration pin. 1. This pin tied to GND, sets 2 cells float voltage. Pin short to GND: 8.4V/8.7V. 2. And the float voltage could be set to any value (3.0V-16.0V) by the external divider resistor.
13	VCC	5V LDO for power driver and internal circuit. Must be bypassed to GND with a minimum of 10 μ F ceramic capacitor for stable operation.
14	GND	Signal GND.
15	CSN	Negative terminal of battery charge current sense.

Notes:

Highlighted pins are high current pins.

BLOCK DIAGRAM

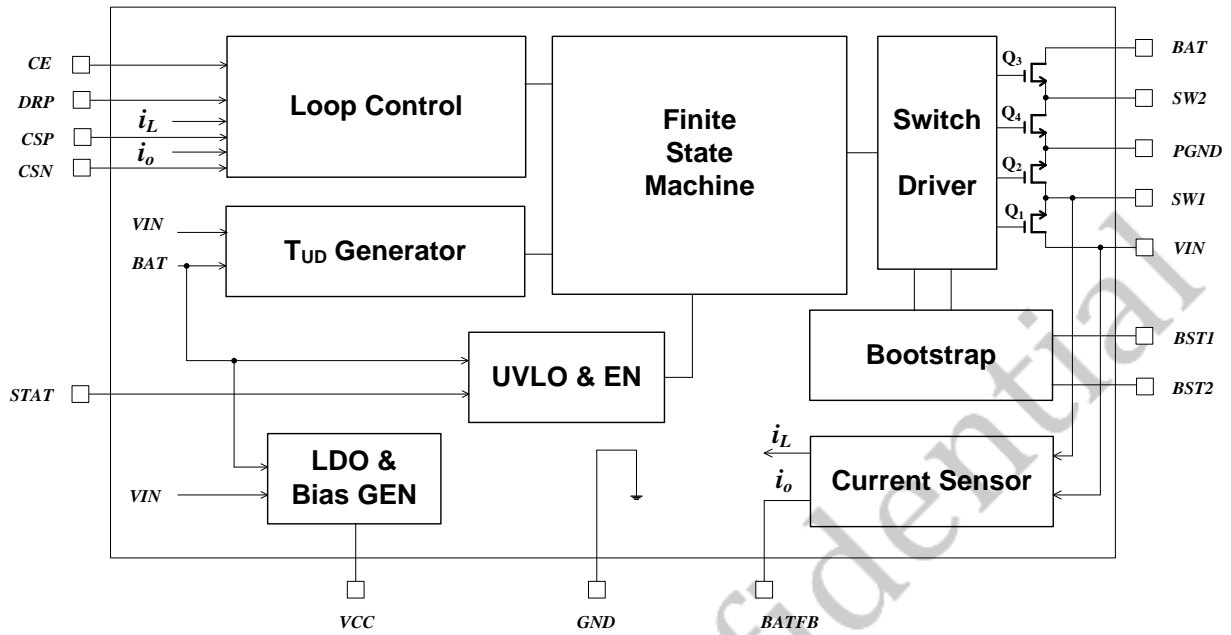

TYPICAL PERFORMANCE CHARACTERISTICS

$V_{IN} = 5V$, $L = 3.3\mu H$, $C_{IN} = 20\mu F$, $C_{OUT} = 20\mu F$, $T_A = +25^\circ C$, unless otherwise noted

Tricklecharge @ 1 cell

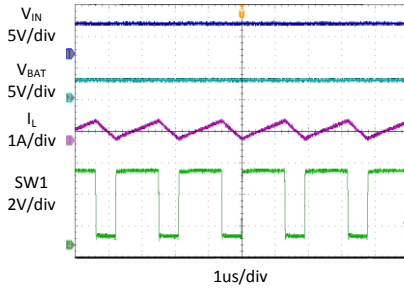

Constantcurrentcharge@ 1 cell

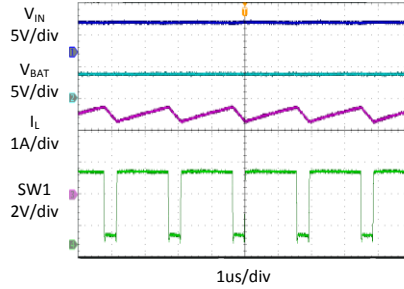

Constantvoltagecharge@ 1 cell

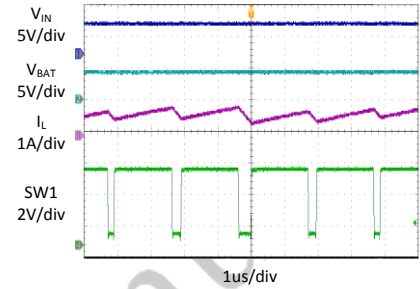

Trickle charge @ 2 cells

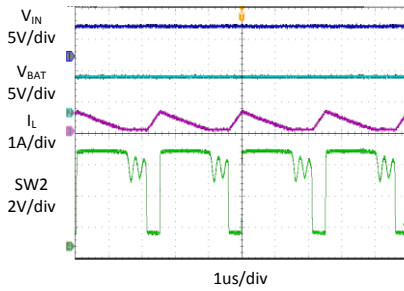

Constant current charge@ 2 cells

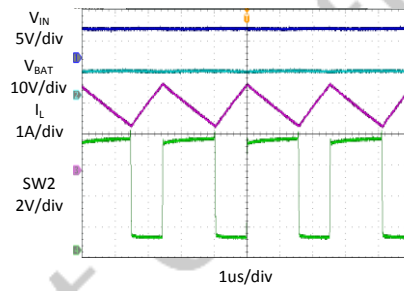

Constant voltage charge@ 2 cells

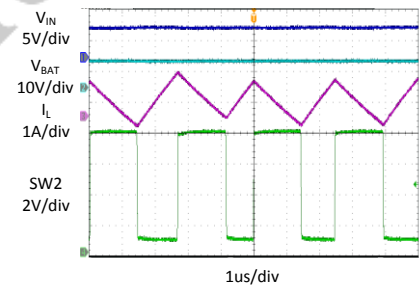

Trickle charge @ 3 cells

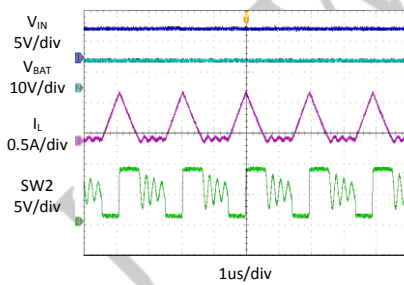

Constant current charge@ 3 cells

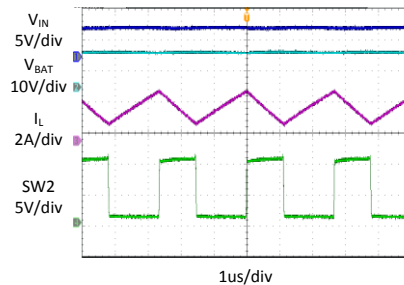

Constant voltage charge@ 3 cells

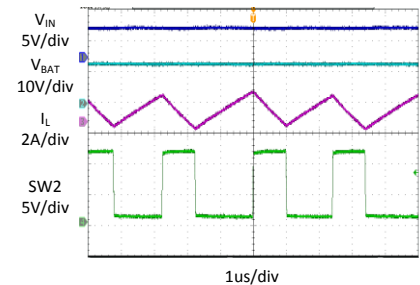

TYPICAL PERFORMANCE CHARACTERISTICS(Continued)

$V_{IN} = 5V$, $L = 3.3\mu H$, $C_{IN} = 20\mu F$, $C_{OUT} = 20\mu F$, $T_A = +25^\circ C$, unless otherwise noted

Charge efficiency @ 1 cell

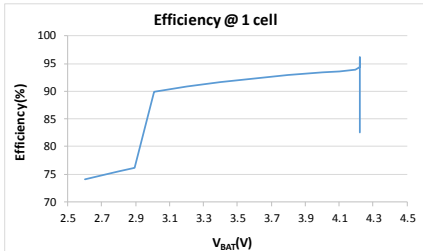

Charge efficiency @ 2 cells

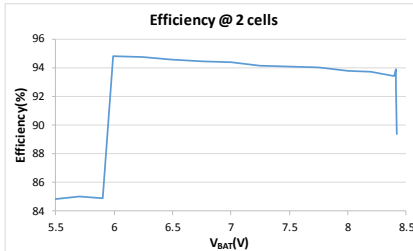

Charge efficiency @ 3 cells

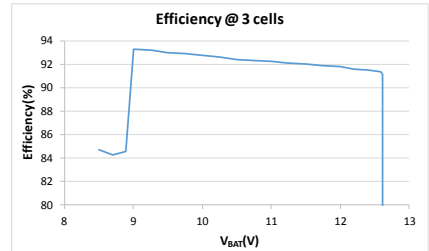

Charge current vs. V_{BAT} @ 1 cell

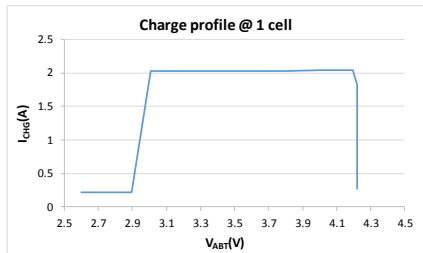

Charge current vs. V_{BAT} @ 2 cells

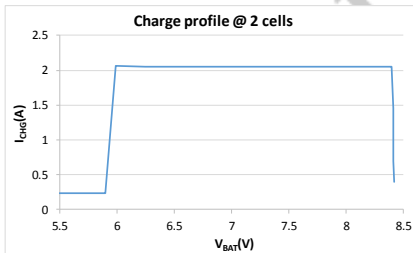

Charge current vs. V_{BAT} @ 3 cells

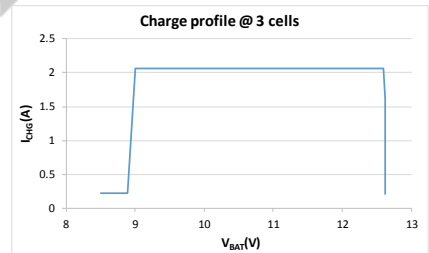

FUNCTIONAL DESCRIPTION

JW3655 is a monolithic buck-boost charger that can operate over a wide input voltage range of 4.2V to 16V. The full charge voltage and charge current can be programmable through external resistor. Low $R_{DS(ON)}$ N-channel power switches reduce the solution complexity and improve the efficiency.

The DC-DC converter utilizes proprietary single inductor current-mode control to guarantee smooth transition between buck and boost operation with better dynamic response and cycle-by-cycle current protection.

Compensation is done internally on the chip. The JW3655 operates in PFM mode at light load. In PFM mode, switching frequency is continuously controlled in proportion to the load current, i.e. switch frequency is decreased when load current drops to boost power efficiency at light load by reducing switching-loss, minimizing the circuit.

The JW3655 can operate in charge mode if a logic High is on CE pin. In charge mode, if the VIN voltage is lower than battery voltage, it is a buck converter. When the VIN voltage is larger than battery voltage, it is a boost converter.

Charge mode

In charge mode, JW3655 regulates the battery current according to input voltage and battery voltage. It charges battery with three phases: trickle charge, constant current charge, constant voltage charge and charge termination. Figure 1(a) is a typical charge profile. Figure 1(b) is a charge profile with input current limit. When the input current is limited, the system decreases the charge current.

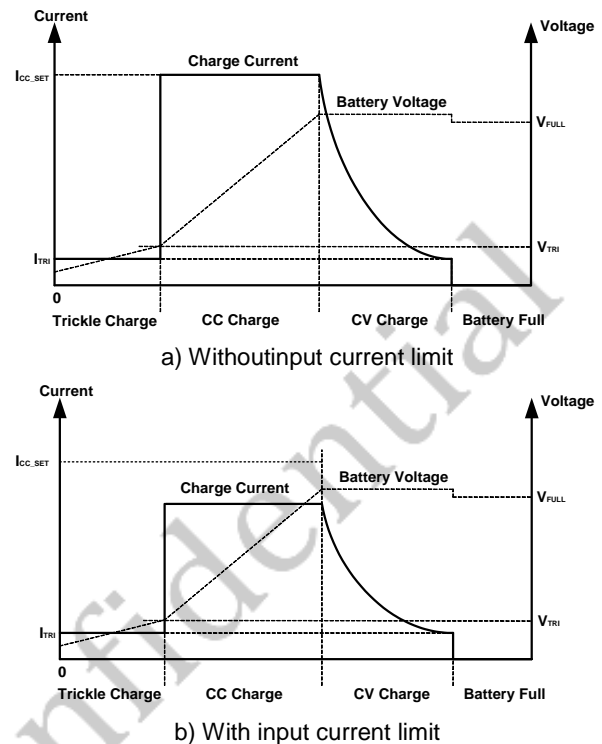

Figure 1 Typical Charge Profile

Trickle charge

The JW3655 charges the battery with I_{TRI} when battery voltage is less than V_{TRI} . If charging remains in TC mode beyond the trickle-charge time T_{TRI} , charging terminates.

CC charge

When the battery is higher than V_{TRI} , the device charges the battery with I_{CC} if the input current is sufficient. When input current limit is hit, the device reduces the charge current automatically. The JW3655 can set the charge current through R_{ISET} . The maximum charge current is up to 3.4A.

$$I_{CC}(A) = \frac{10(A)R_{ISET}(K\Omega)}{R_{CS}(m\Omega)} \quad (1)$$

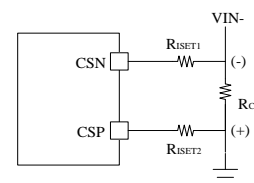

Figure 2 Typical Charge Profile

CV charge

When battery voltage equals to V_{CV} , the device regulates the battery voltage and reduces the charge current reduces automatically.

The customer can select 2 cells or program the V_{CV} through BATFB pin. Connect BATFB to GND selects 2 cells. The V_{CV} can also be programmable by resistor divider connected to BATFB, when the JW3655 detect a resistor connect to this pin. We recommend the 1% accuracy resistor should be used in order to achieve the accuracy of full charge voltage.

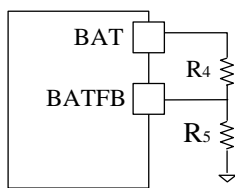

Figure 2 Full Charge Voltage Configure

$$V_{CV} (V) = \frac{1.2V \times (R_4 + R_5)}{R_5} \quad (2)$$

Charge termination

If the battery voltage is higher than V_{FULL} , and the charge current is less than charge termination current I_{TER} for T_{FULL} , the charge process terminates.

Auto recharge

Once the battery charge cycle completes, the charger remains off. A new charge cycle automatically begins when the battery voltage falls below the auto-recharge threshold V_{REC} if the input adaptor is present. The idle mode to charge mode transition also restarts the charge cycle.

Charging status indication description

In charge mode, the charge current is monitored continuously through STAT pin. In the CC charge mode, the pin source current is $6 \mu A$, and if the I_{CC} is 2A, the current sensing ratio is $3 \mu A/A$.

When Charge process terminates, the STAT pin is pulled to high.

If over temperature protection or trickle charge time beyond T_{TRI} , the JW3655B is in fault mode.

the STAT pin will send out high and low voltage alternatively with 1.25Hz.

Dynamic input Current Tracking Scheme

After the CE pin is pulled high, the device detects the VIN pin, if the VIN pin voltage is higher than V_{IN_UV} rising threshold for 150ms, the JW3655 starts charging with a limited charging current, in the meanwhile, the adaptor voltage is detected and stored as initial input voltage. The initial voltage detection circuit is as figure 3. We recommend the ratio of $R1/R2$ is 4.5 in order to detect the initial input voltage.

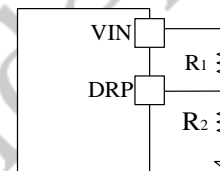

Figure3 VIN Drop Voltage Configure

Then the JW3655 increases charge current step by step, during this process, VIN is continuously monitored. As long as VIN drops preset level (ΔV_{DRP}) below VIN initial voltage, the system step by step lower the input current limit to bring back VIN 100mV higher to maintain a healthy adaptor output. After that the new input current limit is locked up unless the adaptor is plugged out. This is proprietary dynamic input current tracking scheme.

$$\Delta V_{DRP} = R_1 \times 3.7 \mu A \quad (3)$$

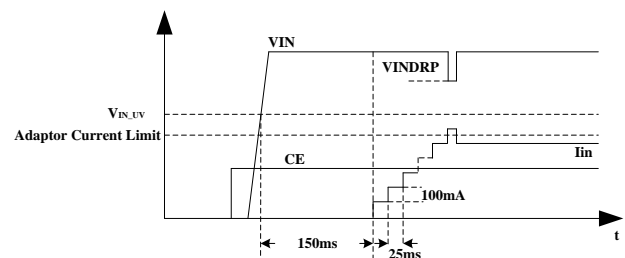

Figure4 Dynamic input Current Tracking

Thermal Control

When the junction temperature of the JW3655 rises above 135°C, it begins to reduce the output power to prevent the temperature from rising further. If the junction temperature of the JW3655 rises above 150°C, the discharging process stops.

Shut-down Mode

The JW3655 shuts down when voltage at CE pin is below 0.8V. The entire regulator is off.

PCB Layout Note

For minimum noise problem and best operating performance, the PCB is preferred to following the guidelines as reference.

1. Place the input decoupling capacitor as close to JW3655B (VIN pin and PGND) as possible to eliminate noise at the input pin. The loop area formed by input capacitor and GND must be minimized.
2. Put the current sense resistor R_{CS} as close as possible to the current set resistors R_{ISET} for better current accuracy.
3. The ground plane on the PCB should be as large as possible for better heat dissipation

Reference Design

Reference 1: Single cell charge with input current limit

V_{IN} : 4.5V ~ 16V

V_{BAT} : 3V ~ 4.2V

I_{IN_LIM} : 2A

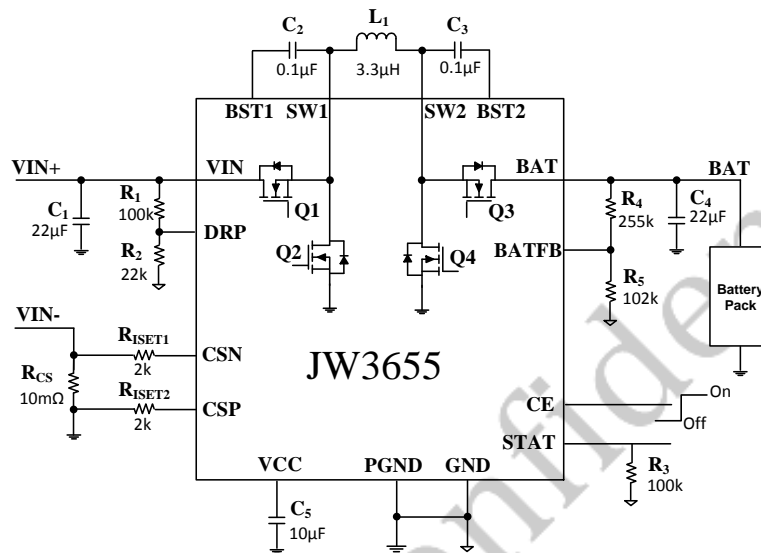

Reference 2: 2 cells charge with input current limit

V_{IN} : 4.5V ~ 16V

V_{BAT} : 6V ~ 8.4V

I_{IN_LIM} : 2A

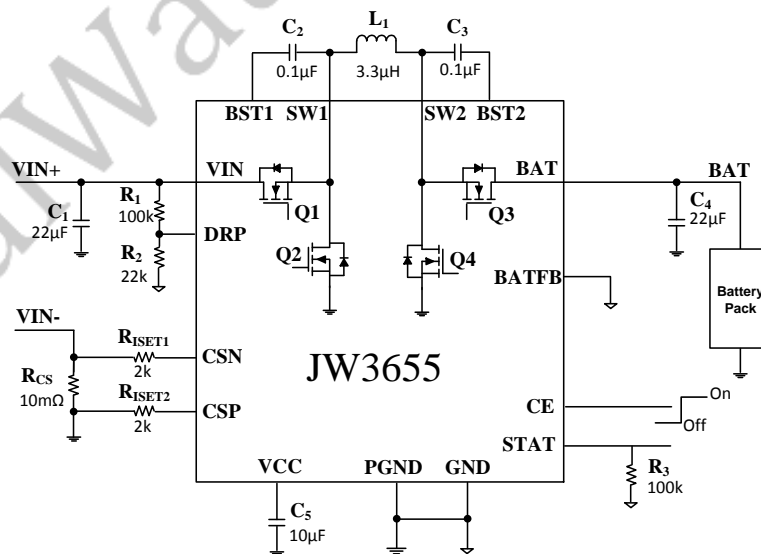

Reference 3: 3 cells charge with input current limit

V_{IN} : 4.5V ~ 16V

V_{BAT} : 9V ~ 12.6V

I_{IN_LIM} : 2A

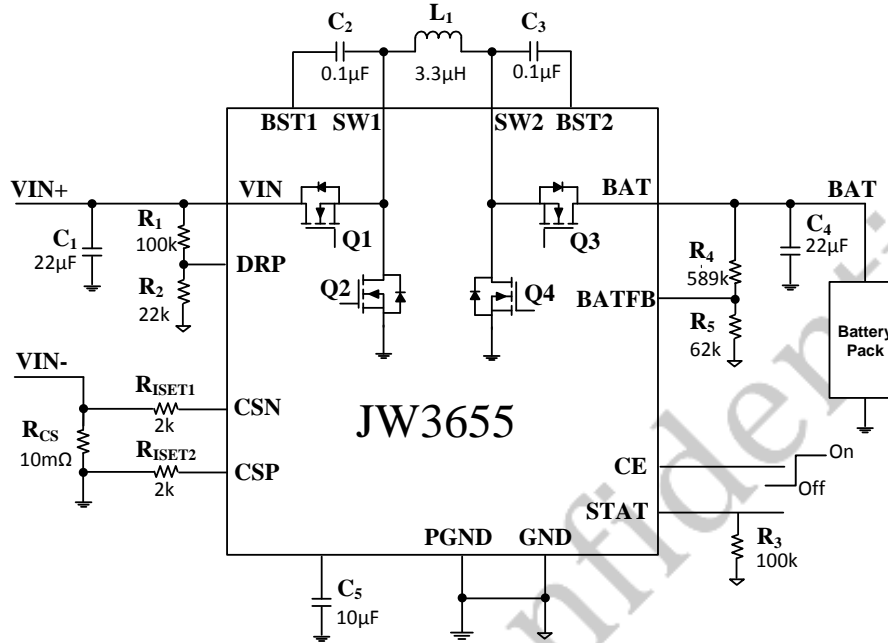

Reference 4: Single cell charge with battery current limit

V_{IN} : 4.5V ~ 16V

V_{BAT} : 3V ~ 4.2V

I_{BAT_LIM} : 2A

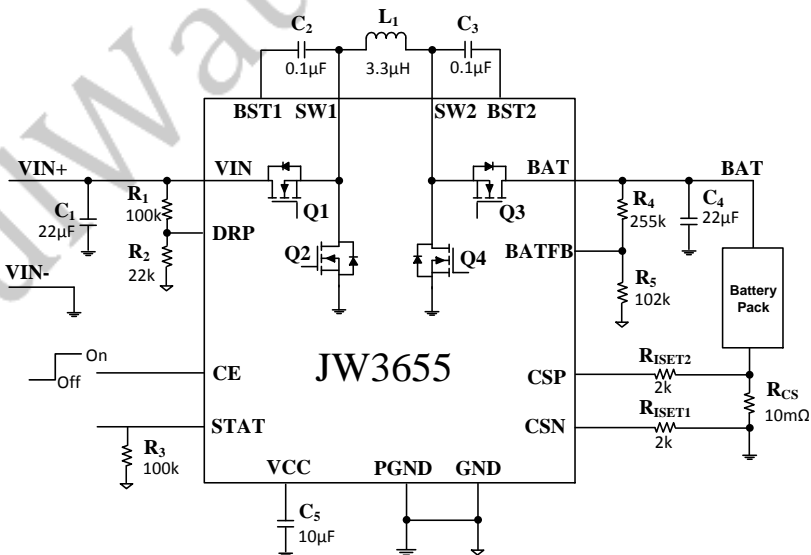

PACKAGE OUTLINE

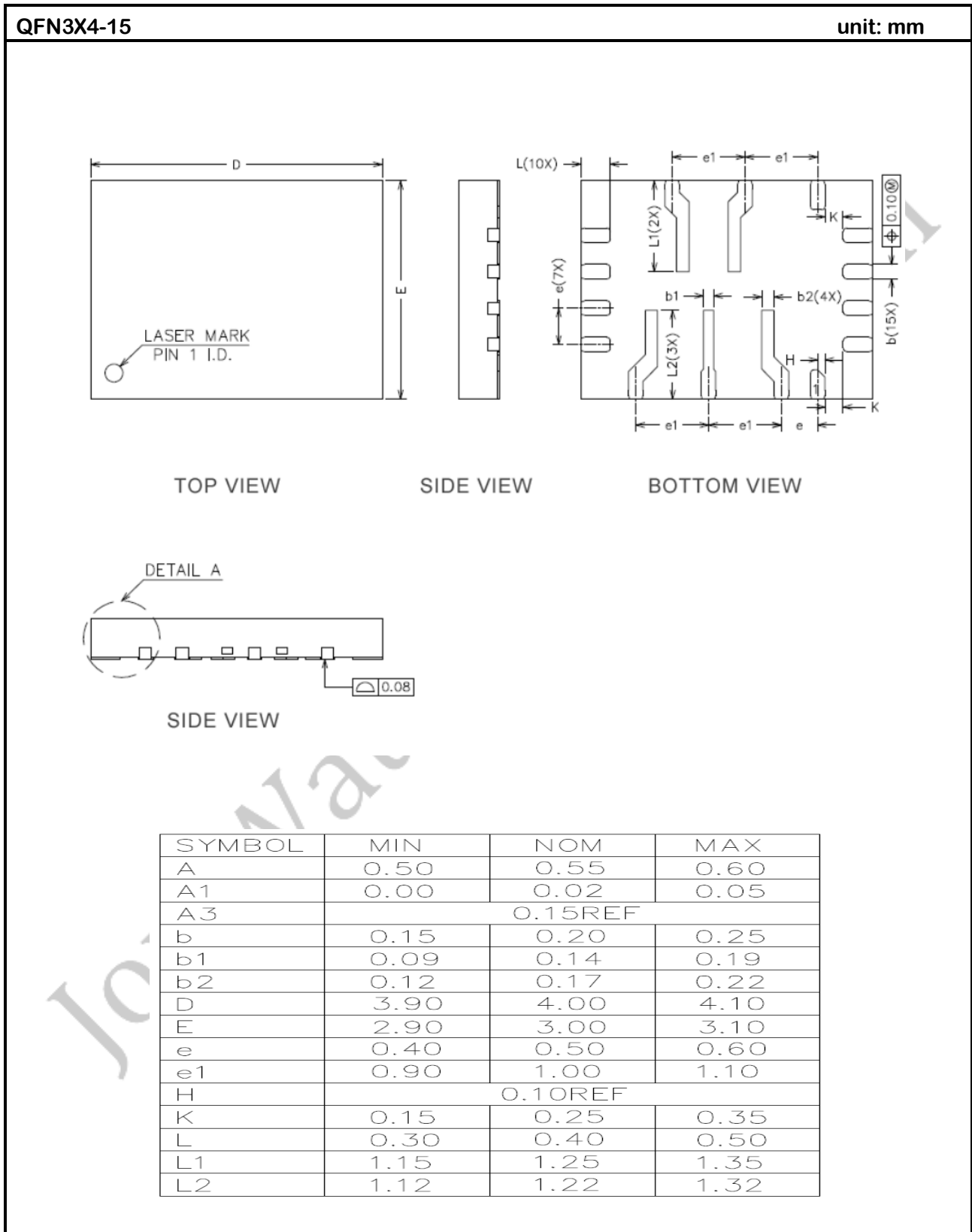

IMPORTANT NOTICE

- Joulwatt Technology Inc. reserves the right to make modifications, enhancements, improvements, corrections or other changes without further notice to this document and any product described herein.
- Any unauthorized redistribution or copy of this document for any purpose is strictly forbidden.
- Joulwatt Technology Inc. does not warrant or accept any liability whatsoever in respect of any products purchased through unauthorized sales channel.

JoulWatt Confidential

Copyright © 2017 JW3655 Incorporated.

All rights are reserved by Joulwatt Technology Inc.