

### DESCRIPTION

The JW<sup>®</sup>5026 is a current mode monolithic buck switching regulator. Operating with an input range of 4.7V~40V, the JW5026 delivers 1A of continuous output current with two integrated N-Channel MOSFETs. The internal synchronous power switches provide high efficiency without the use of an external Schottky diode. At light loads, the regulator operates in continual conduction mode to maintain low output ripple. Current mode control provides tight load transient response and cycle-by-cycle current limit.

The JW5026 guarantees robustness with short-circuit protection, thermal protection, current run-away protection, and input under voltage lockout.

The JW5026 is available in 6-pin SOT23-6 package, which provides a compact solution with minimal external components.

*Company's Logo is Protected, "JW" and "JOULWATT" are Registered Trademarks of JoulWatt technology Inc.*

### FEATURES

- 4.7V to 40V operating input range
- 1A output current
- Up to 93% efficiency
- FCC at light load
- Internal Soft-Start
- 1.1MHz switching frequency
- Input under voltage lockout
- Available in SOT23-6 package
- Current run-away protection
- Short circuit protection
- Thermal protection

### APPLICATIONS

- Distributed Power Systems
- Automotive Systems
- High Voltage Power Conversion
- Industrial Power Systems
- Battery Powered Systems

### TYPICAL APPLICATION

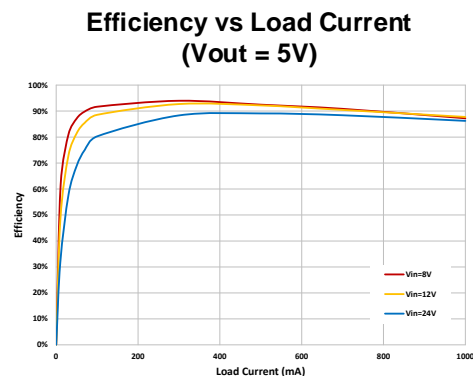
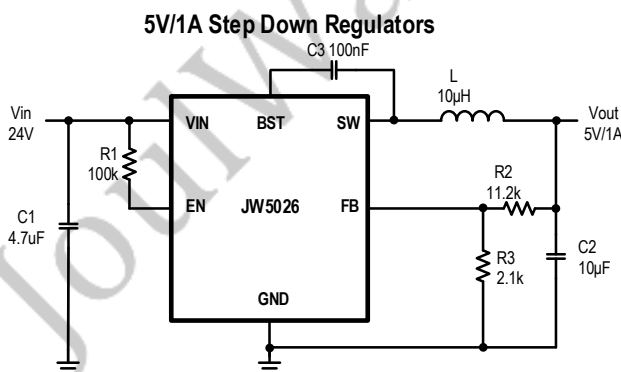

ORDER INFORMATION

DEVICE <sup>1)</sup>	PACKAGE	TOP MARKING <sup>2)</sup>
JW5026SOTB#TRPBF	SOT23-6	JWBH□ YW□□□

Notes:

1) JW□□□#TRPBF  
 PB Free  
 Tape and Reel (if "TR" is not shown, it means tube)  
 Package Code  
 Part No.

2) Line1: JW□□□ Internal control code  
 Product code  
 Joulwatt LOGO  
 Line2: YW□□□ Lot number  
 Week code  
 Year code

PIN CONFIGURATION

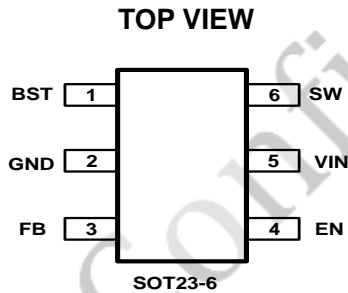

ABSOLUTE MAXIMUM RATING<sup>1)</sup>

VIN, EN, SW Pin	-0.3V to 44V
SW Pin	-0.3V(-7V for 5ns) to 44V (45V for 5ns)
BST Pin	SW-0.3V to SW+5V
All other Pins	-0.3V to 6V
Junction Temperature <sup>2)</sup>	150°C
Lead Temperature	260°C
Storage Temperature	-65°C to +150°C

RECOMMENDED OPERATING CONDITIONS<sup>3)</sup>

Input Voltage VIN	4.7V to 40V
Output Voltage Vout	0.8V to VIN-3V
Operating Junction Temperature	-40°C to 125°C

THERMAL PERFORMANCE<sup>4)</sup>

	$\theta_{JA}$	$\theta_{JC}$
SOT23-6	220	130°C/W

**Note:**

- 1) Exceeding these ratings may damage the device. These stress ratings do not imply function operation of the device at any other conditions beyond those indicated under RECOMMEND OPERATION CONDITIONS.
- 2) The JW5026 includes thermal protection that is intended to protect the device in overload conditions. Continuous operation over the specified absolute maximum operating junction temperature may damage the device.
- 3) The device is not guaranteed to function outside of its operating conditions.
- 4) Measured on JESD51-7, 4-layer PCB.

JoulWatt Confidential

## ELECTRICAL CHARACTERISTICS

$V_{IN} = 12V, T_A = 25^{\circ}C$ , unless otherwise stated.						
Item	Symbol	Condition	Min.	Typ.	Max.	Units
$V_{IN}$ Under voltage Lockout Threshold	$V_{IN\_MIN}$	$V_{IN}$ rising	4	4.3	4.6	V
$V_{IN}$ Under voltage Lockout Hysteresis	$V_{IN\_MIN\_HYST}$		140	250	360	mV
Shutdown Supply Current	$I_{SD}$	$V_{EN}=0V$		0.1	1	$\mu A$
Supply Current	$I_Q$	$V_{EN}=5V, V_{FB}=1.2V$		40	60	$\mu A$
Feedback Voltage	$V_{FB}$	$4.7V < V_{IN} < 40V$	780	800	820	mV
Top Switch Resistance <sup>5)</sup>	$R_{DS(ON)T}$			500	600	m $\Omega$
Bottom Switch Resistance <sup>5)</sup>	$R_{DS(ON)B}$			220	264	m $\Omega$
Top Switch Leakage Current	$I_{LEAK\_TOP}$	$V_{IN}=40V, V_{EN}=0V, V_{SW}=0V$			1	$\mu A$
Bottom Switch Leakage Current	$I_{LEAK\_BOT}$	$V_{IN} = V_{SW} = 40V, V_{EN}=0V$			1	$\mu A$
Top Switch Current Limit <sup>5)</sup>	$I_{LIM\_TOP}$	Minimum Duty Cycle		1.7	2.04	A
Negative Current Limit <sup>5)</sup>	$I_{LIM\_Neg}$	$I_{LIM\_NEG}$		-0.38		A
Switch Frequency	$f_{SW}$		0.75	1.1	1.25	MHz
Minimum On Time <sup>5)</sup>	$T_{ON\_MIN}$			80	96	ns
Minimum Off Time <sup>5)</sup>	$T_{OFF\_MIN}$	$V_{FB}=0V$		100	120	ns
EN shut down threshold voltage	$V_{EN\_TH}$	$V_{EN}$ rising, $FB=0V$	1.18	1.3	1.42	V
EN shut down hysteresis	$V_{EN\_HYST}$		80	120	180	mV
Thermal Shutdown <sup>5)</sup>	$T_{TSD}$		120	135	150	$^{\circ}C$
Thermal Shutdown hysteresis <sup>5)</sup>	$T_{TSD\_HYST}$			15		$^{\circ}C$

**Note:**

5) Guaranteed by design.

**PIN DESCRIPTION**

Pin	Name	Description
1	BST	Bootstrap pin for top switch. A 0.1uF or larger capacitor should be connected between this pin and the SW pin to supply current to the top switch and top switch driver.
2	GND	Ground.
3	FB	Output feedback pin. FB senses the output voltage and is regulated by the control loop to 800mV. Connect a resistive divider at FB.
4	EN	Drive EN pin high to turn on the regulator and low to turn off the regulator.
5	VIN	Input voltage pin. VIN supplies power to the IC. Connect a 4.7V to 40V supply to VIN and bypass VIN to GND with a suitably large capacitor to eliminate noise on the input to the IC.
6	SW	SW is the switching node that supplies power to the output. Connect the output LC filter from SW to the output load.

**BLOCK DIAGRAM**

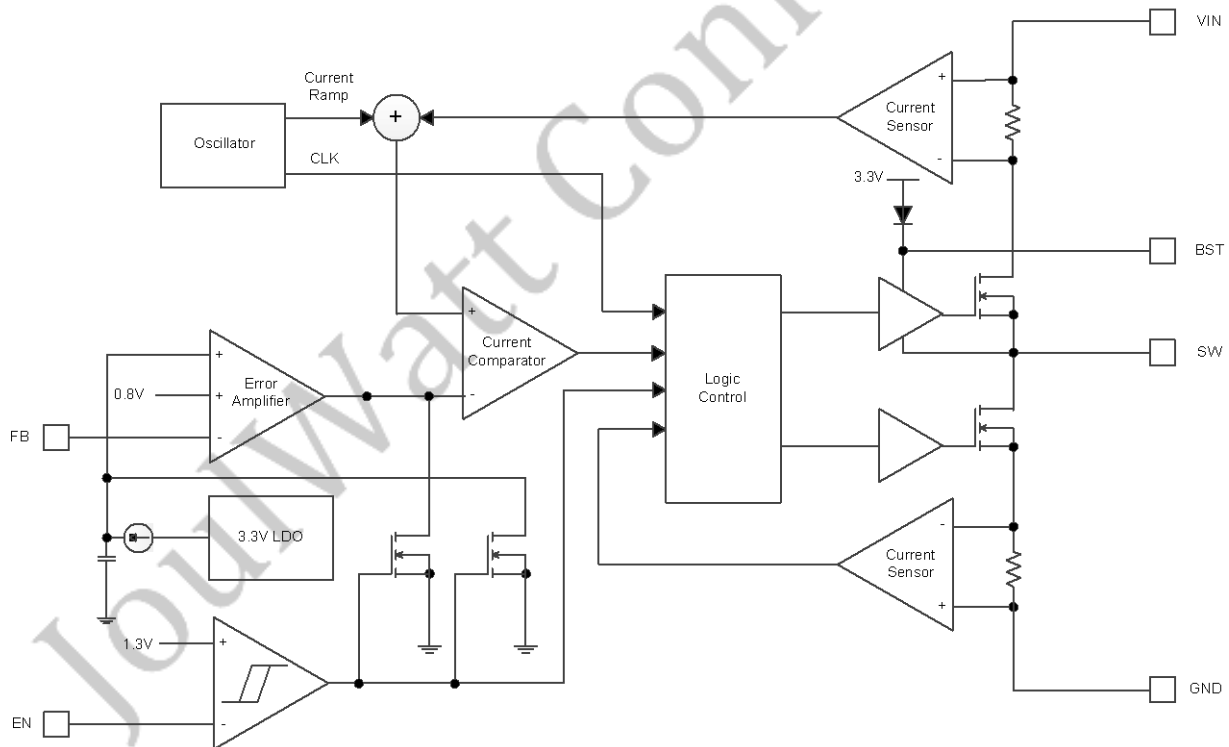

## TYPICAL PERFORMANCE CHARACTERISTICS

Vin = 12V, Vout = 5V, L = 10μH, C2= 10μF, TA = +25°C, unless otherwise noted

### Steady State Test

VIN=12V, Vout=5V  
Iout=1A

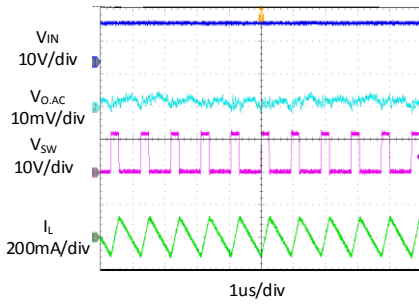

### Startup through Enable

VIN=12V, Vout=5V  
Iout=1A (Resistive load)

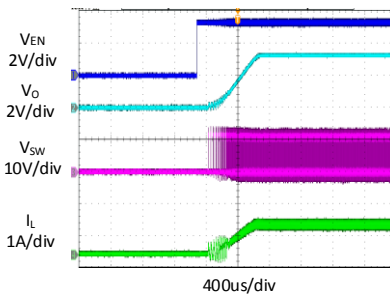

### Shutdown through Enable

VIN=12V, Vout=5V  
Iout=1A (Resistive load)

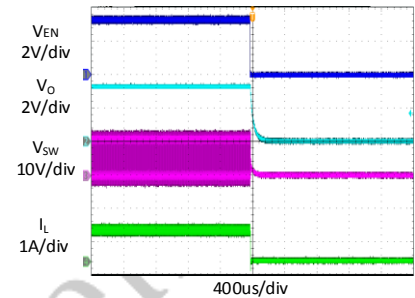

### Heavy Load Operation

1A LOAD

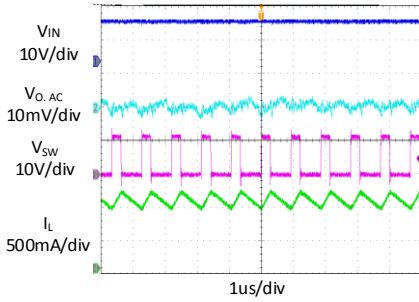

### Medium Load Operation

500mA LOAD

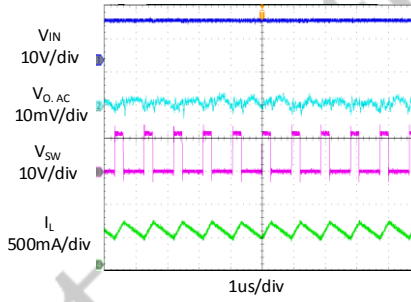

### Light Load Operation

0 A LOAD

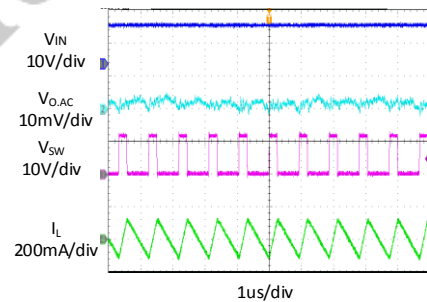

### Short Circuit Protection

VIN=12V, Vout=5V  
Iout=1A- Short

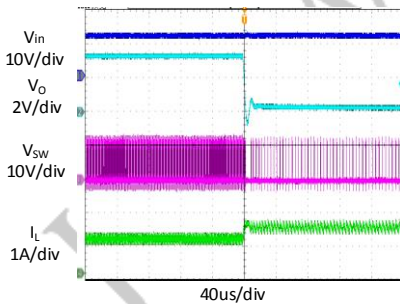

### Short Circuit Recovery

VIN=12V, Vout=5V  
Iout= Short-1A

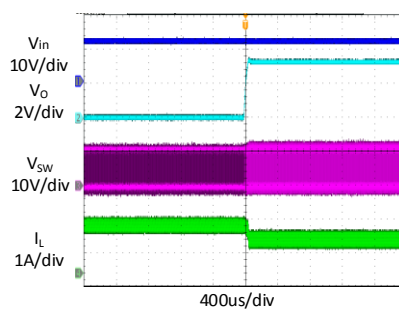

### Load Transient

500mA LOAD → 1A LOAD  
→ 500mA LOAD

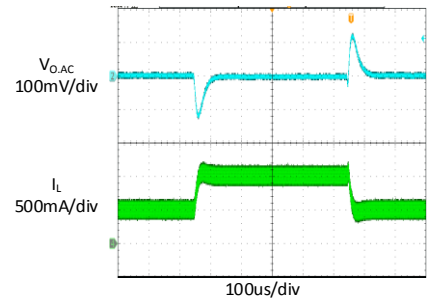

## FUNCTIONAL DESCRIPTION

The JW5026 is a synchronous, current-mode, step-down regulator. It regulates input voltages from 4.7V to 40V down to an output voltage as low as 0.8V, and is capable of supplying up to 1A of load current.

### Current-Mode Control

The JW5026 utilizes current-mode control to regulate the output voltage. The output voltage is measured at the FB pin through a resistive voltage divider and the error is amplified by the internal transconductance error amplifier.

Output of the internal error amplifier is compared with the switch current measured internally to control the output current.

### Continuous Conduction Mode

The JW5026 operates in continuous conduction mode. At light load, the inductor current will reach negative current to keep the fixed frequency.

### Shut-Down Mode

The JW5026 shuts down when voltage at EN pin is below 0.3V. The entire regulator is off and the supply current consumed by the JW5026 drops below 0.1uA.

### Power Switch

N-Channel MOSFET switches are integrated on the JW5026 to down convert the input voltage to the regulated output voltage. Since the top MOSFET needs a gate voltage great than the input voltage, a boost capacitor connected between BST and SW pins is required to drive the gate of the top switch. The boost capacitor is charged by the internal 3.3V rail when SW is low.

### Vin Under-Voltage Protection

A resistive divider can be connected between Vin and ground, with the central tap connected to EN, so that when Vin drops to the pre-set value, EN drops below 1.2V to trigger input under voltage lockout protection.

### Output Current Run-Away Protection

At start-up, due to the high voltage at input and low voltage at output, current inertia of the output inductance can be easily built up, resulting in a large start-up output current. A valley current limit is designed in the JW5026 so that only when output current drops below the valley current limit can the top power switch be turned on. By such control mechanism, the output current at start-up is well controlled.

### Output Short Protection

When output is shorted to ground, output current rapidly reaches its peak current limit and the top power switch is turned off. Right after the top power switch is turned off, the bottom power switch is turned on and stay on until the output current falls below the valley current limit. When output current is below the valley current limit, the top power switch will be turned on again and if the output short is still present, the top power switch is turned off when the peak current limit is reached and the bottom power switch is turned on. This cycle goes on until the output short is removed and the regulator comes into normal operation again.

### Thermal Protection

When the temperature of the JW5026 rises above 135°C, it is forced into thermal shut-down.

Only when core temperature drops below 120°C can the regulator becomes active again.

## APPLICATION INFORMATION

### Output Voltage Set

The output voltage is determined by the resistor divider connected at the FB pin, and the voltage ratio is:

$$V_{FB} = V_{OUT} \cdot \frac{R_3}{R_2 + R_3}$$

where  $V_{FB}$  is the feedback voltage and  $V_{OUT}$  is the output voltage.

Choose  $R_3$  around 2.1kΩ, and then  $R_2$  can be calculated by:

$$R_2 = R_3 \cdot \left( \frac{V_{OUT}}{0.8V} - 1 \right)$$

The following table lists the recommended values.

V <sub>OUT</sub> (V)	R <sub>3</sub> (kΩ)	R <sub>2</sub> (kΩ)
2.5	4.99	11
3.3	2.4	7.5
5	2.1	11.2

### Input Capacitor

The input capacitor is used to supply the AC input current to the step-down converter and maintaining the DC input voltage. The ripple current through the input capacitor can be calculated by:

$$I_{C1} = I_{LOAD} \cdot \sqrt{\frac{V_{OUT}}{V_{IN}} \cdot \left( 1 - \frac{V_{OUT}}{V_{IN}} \right)}$$

where  $I_{LOAD}$  is the load current,  $V_{OUT}$  is the output voltage,  $V_{IN}$  is the input voltage.

Thus the input capacitor can be calculated by the following equation when the input ripple voltage is determined.

$$C_1 = \frac{I_{LOAD}}{f_s \cdot \Delta V_{IN}} \cdot \frac{V_{OUT}}{V_{IN}} \cdot \left( 1 - \frac{V_{OUT}}{V_{IN}} \right)$$

where  $C_1$  is the input capacitance value,  $f_s$  is the

switching frequency,  $\Delta V_{IN}$  is the input ripple current.

The input capacitor can be electrolytic, tantalum or ceramic. To minimizing the potential noise, a small X5R or X7R ceramic capacitor, i.e. 0.1uF, should be placed as close to the IC as possible when using electrolytic capacitors.

A 4.7uF ceramic capacitor is recommended in typical application, and an extra 47uF electrolytic capacitor is needed if hot-plug is required.

### Output Capacitor

The output capacitor is required to maintain the DC output voltage, and the capacitance value determines the output ripple voltage. The output voltage ripple can be calculated by:

$$\Delta V_{OUT} = \frac{V_{OUT}}{f_s \cdot L} \cdot \left( 1 - \frac{V_{OUT}}{V_{IN}} \right) \cdot \left( R_{ESR} + \frac{1}{8 \cdot f_s \cdot C_2} \right)$$

where  $C_2$  is the output capacitance value and  $R_{ESR}$  is the equivalent series resistance value of the output capacitor.

The output capacitor can be low ESR electrolytic, tantalum or ceramic, which lower ESR capacitors get lower output ripple voltage.

The output capacitors also affect the system stability and transient response, and a 10uF ceramic capacitor is recommended in typical application.

### Inductor

The inductor is used to supply constant current to the output load, and the value determines the ripple current which affect the efficiency and the output voltage ripple. The ripple current is typically allowed to be 30% of the maximum



switch current limit, thus the inductance value can be calculated by:

$$L = \frac{V_{OUT}}{f_s \cdot \Delta I_L} \cdot \left(1 - \frac{V_{OUT}}{V_{IN}}\right)$$

where  $V_{IN}$  is the input voltage,  $V_{OUT}$  is the output voltage,  $f_s$  is the switching frequency, and  $\Delta I_L$  is the peak-to-peak inductor ripple current.

**External Bootstrap Capacitor**

A bootstrap capacitor is required to supply voltage to the top switch driver. A 0.1uF low ESR ceramic capacitor is recommended to be connected to the BST pin and SW pin.

**PCB Layout Note**

For minimum noise problem and best operating performance, the PCB is preferred to following the guidelines as reference.

1. Place the input decoupling capacitor as close to JW5026 ( $V_{IN}$  pin and PGND) as possible to eliminate noise at the input pin. The loop area formed by input capacitor and GND must be minimized.
2. Put the feedback trace as far away from the inductor and noisy power traces as possible.

3. The ground plane on the PCB should be as large as possible for better heat dissipation

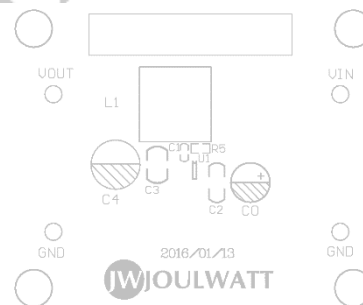
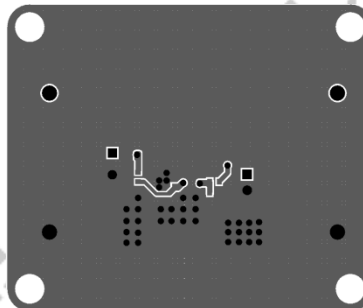
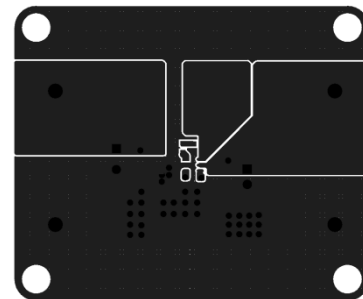

REFERENCE DESIGN

Reference 1:

$V_{IN}$  : 24 V  
 $V_{OUT}$ : 3.3V  
 $I_{OUT}$  : 0~1A

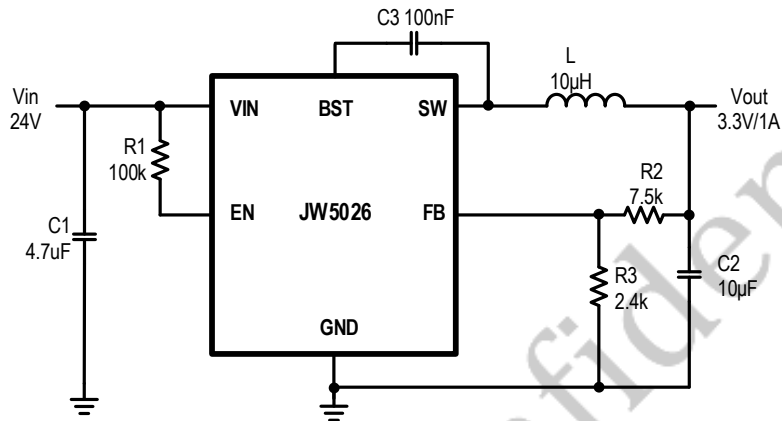

Reference 2:

$V_{IN}$  : 24V  
 $V_{OUT}$ : 5V  
 $I_{OUT}$  : 0~1A

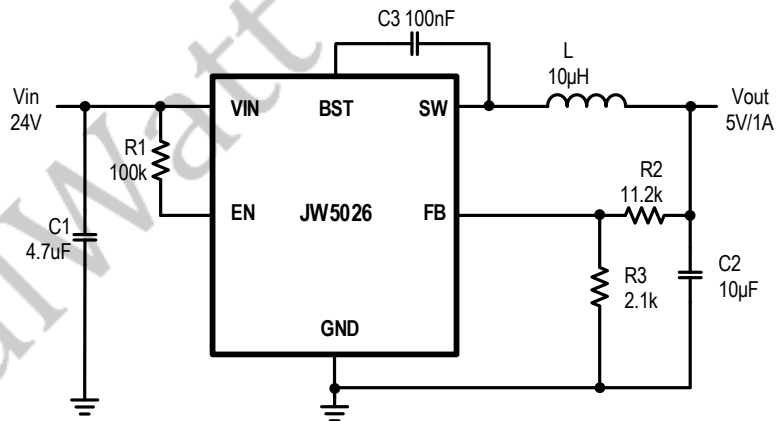

PACKAGE OUTLINE

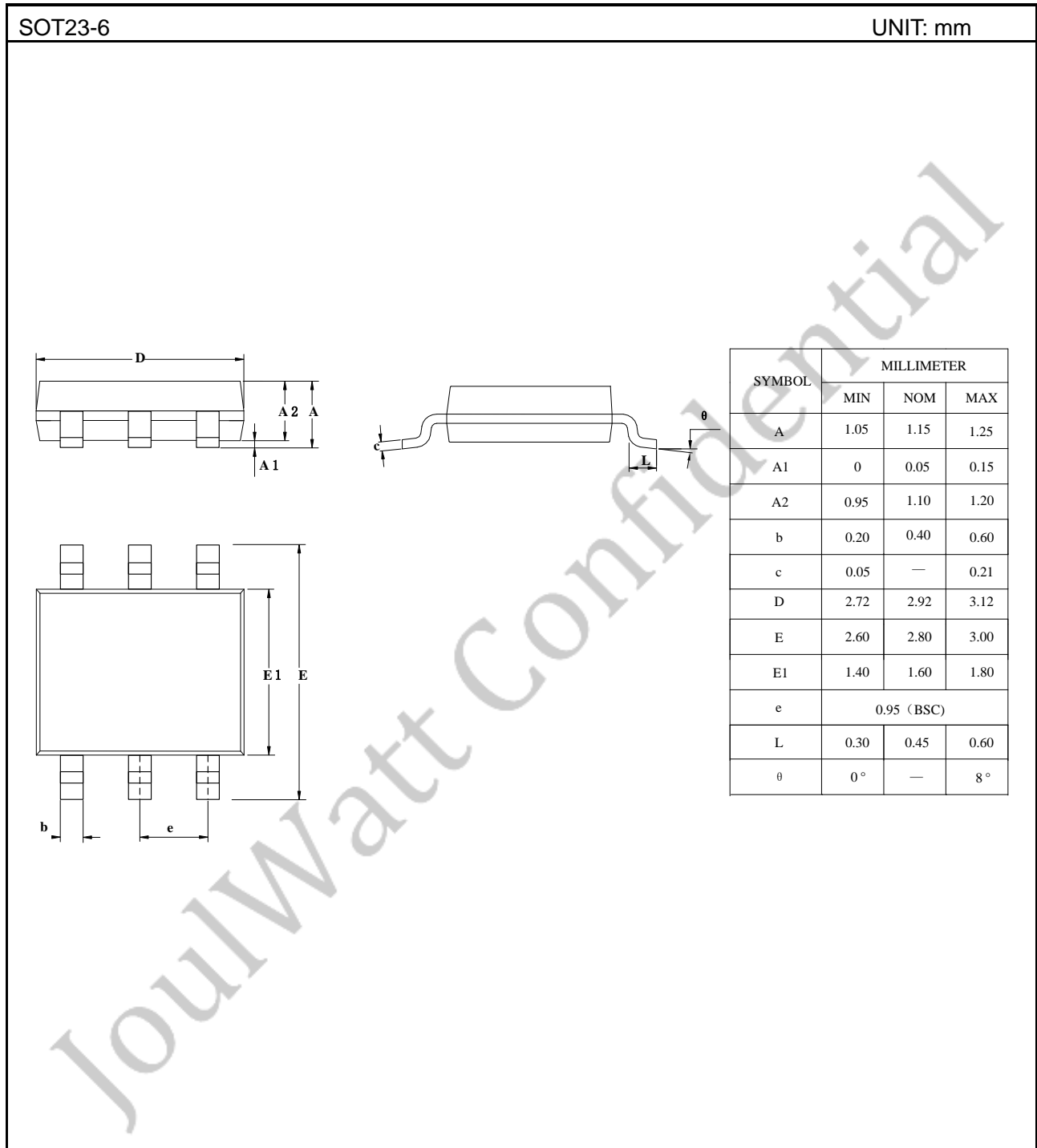

**IMPORTANT NOTICE**

- Joulwatt Technology Inc. reserves the right to make modifications, enhancements, improvements, corrections or other changes without further notice to this document and any product described herein.
- Any unauthorized redistribution or copy of this document for any purpose is strictly forbidden.
- Joulwatt Technology Inc. does not warrant or accept any liability whatsoever in respect of any products purchased through unauthorized sales channel.

JoulWatt Confidential

*Copyright © 2015 JW5026 Incorporated.*

*All rights are reserved by Joulwatt Technology Inc.*