

Features

- Diffused Junction
- Low Forward Voltage Drop
- High Current Capability
- High Reliability
- High Surge Current Capability
- Ideal for Printed Circuit Boards
- UL Recognized File # E157705

Mechanical Data

- Case: Molded Plastic
- Terminals: Plated Leads Solderable per MIL-STD-202, Method 208
- Polarity: As Marked on Body
- Weight: 8.0 grams (approx.)
- Mounting Position: Any
- Marking: Type Number

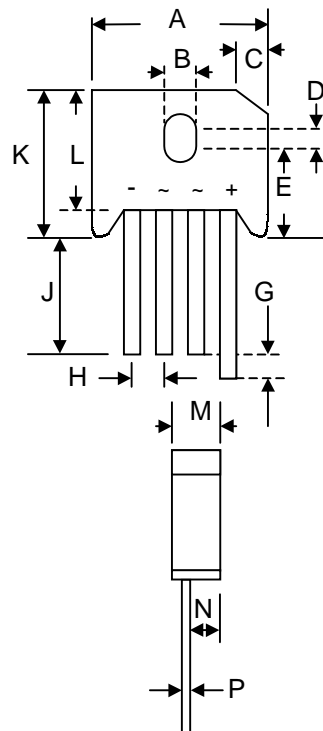

KBU		
Dim	Min	Max
A	22.70	23.70
B	3.80	4.10
C	4.20	4.70
D	1.70	2.20
E	10.30	11.30
G	4.50	6.80
H	4.60	5.60
J	25.40	—
K	—	19.30
L	16.80	17.80
M	6.60	7.10
N	4.70	5.20
P	1.20	1.30
All Dimensions in mm		

Maximum Ratings and Electrical Characteristics @T_A=25°C unless otherwise specified

Single Phase, half wave, 60Hz, resistive or inductive load.
For capacitive load, derate current by 20%.

Characteristic	Symbol	KBU 600	KBU 601	KBU 602	KBU 604	KBU 606	KBU 608	KBU 610	Units
Peak Repetitive Reverse Voltage Working Peak Reverse Voltage DC Blocking Voltage	V _{RRM} V _{RWM} V _R	50	100	200	400	600	800	1000	V
RMS Reverse Voltage	V _{R(RMS)}	35	70	140	280	420	560	700	V
Average Rectified Output Current @T _C = 100°C	I _O	6.0							A
Non-Repetitive Peak Forward Surge Current 8.3ms Single half sine-wave superimposed on rated load (JEDEC Method)	I _{FSM}	250							A
Forward Voltage (per element) @I _F = 3.0A	V _{FM}	1.0							V
Peak Reverse Current @T _C = 25°C At Rated DC Blocking Voltage @T _C = 100°C	I _R	10 1.0							μA mA
Rating for Fusing (t < 8.3ms) (Note 1)	I _t ²	166							A ² s
Typical Thermal Resistance (Note 2)	R _{θJC}	4.2							K/W
Operating and Storage Temperature Range	T _j , T _{STG}	-65 to +150							°C

Note: 1. Non-repetitive for t > 1ms and < 8.3ms.
2. Thermal resistance junction to case per element mounted on PC board with 13.0x13.0x0.03mm thick land areas.

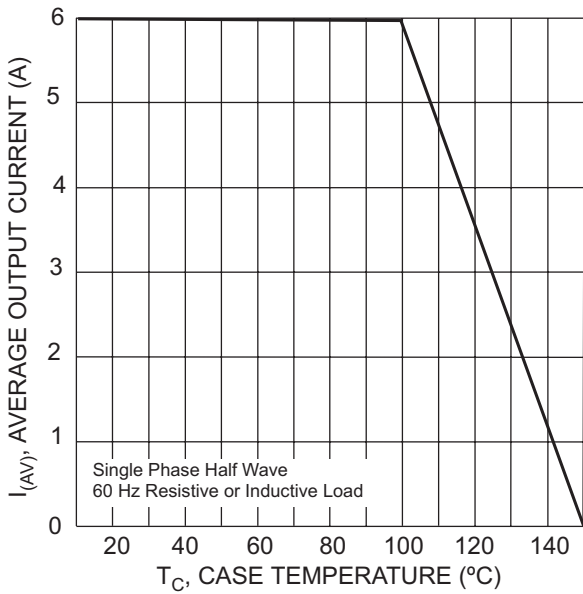

Fig. 1 Forward Current Derating Curve

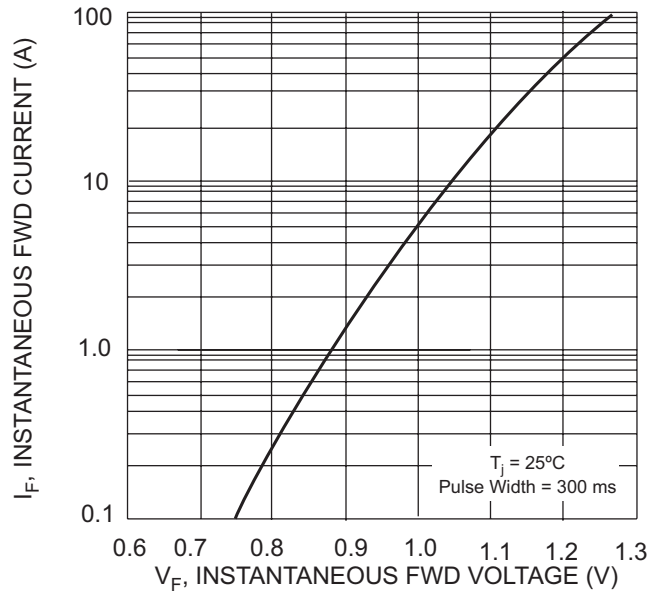

Fig. 2 Typical Forward Characteristics, per element

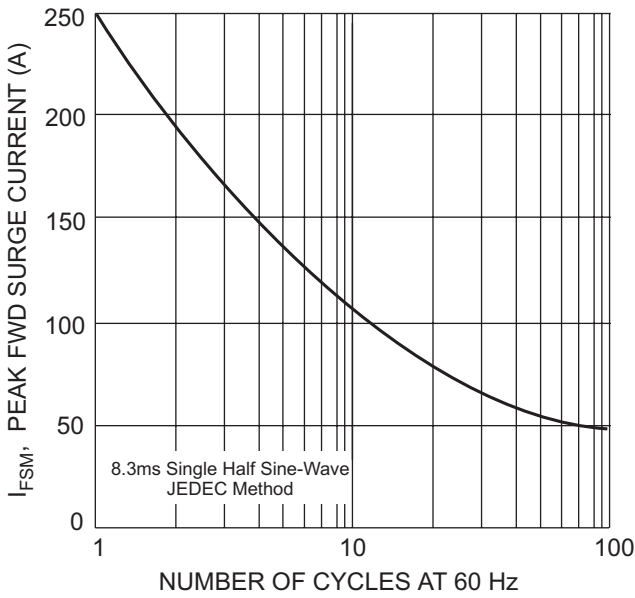

Fig. 3 Max Non-Repetitive Peak Fwd Surge Current

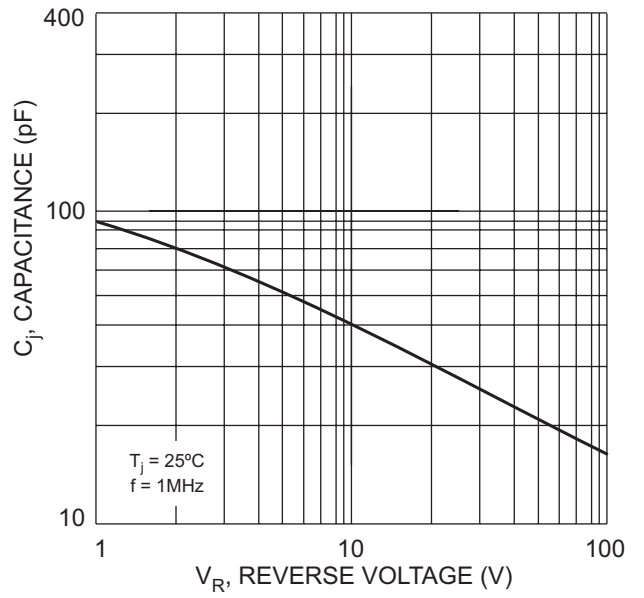

Fig. 4 Typical Junction Capacitance Per Element

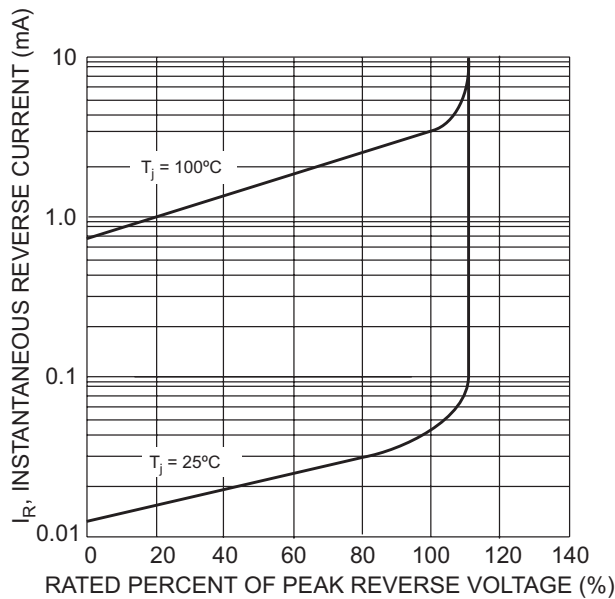

Fig. 5 Typical Reverse Characteristics

ORDERING INFORMATION

Product No.	Package Type	Shipping Quantity
KBU600	SIL Bridge	400 Units/Box
KBU601	SIL Bridge	400 Units/Box
KBU602	SIL Bridge	400 Units/Box
KBU604	SIL Bridge	400 Units/Box
KBU606	SIL Bridge	400 Units/Box
KBU608	SIL Bridge	400 Units/Box
KBU610	SIL Bridge	400 Units/Box

Shipping quantity given is for minimum packing quantity only. For minimum order quantity, please consult the Sales Department.