

GS Oxygen Sensors

Features:

- * Long life
KE-25 - 5 years / KE-50 - 10 years in ambient air
- * Virtually no influence from CO₂, CO, H₂S, NO_x, H₂
- * Low cost
- * Operates in normal ambient temperatures
- * Stable output signal
- * No external power supply required for sensor operation
- * No warmup time is required

Applications:

- * Medical - Anesthetic instruments, respirators, oxygen-enrichers
- * Biotechnology - Oxygen incubators
- * Food industry - Refrigeration, greenhouses
- * Safety - Air conditioners, oxygen detectors, fire detectors

The GS Oxygen Sensor KE series (KE-25 and KE-50) is a unique galvanic cell type oxygen sensor which was developed in Japan in 1985. Its most notable features are long life expectancy, excellent chemical durability, and it is not influenced by CO₂. The KE series oxygen sensor is ideal to meet the ever-increasing demand for oxygen monitoring in various fields such as combustion gas monitoring, the biochemical field, medical applications, domestic combustion appliances, etc.



Sensitivity characteristics (typical values under std. test conditions)

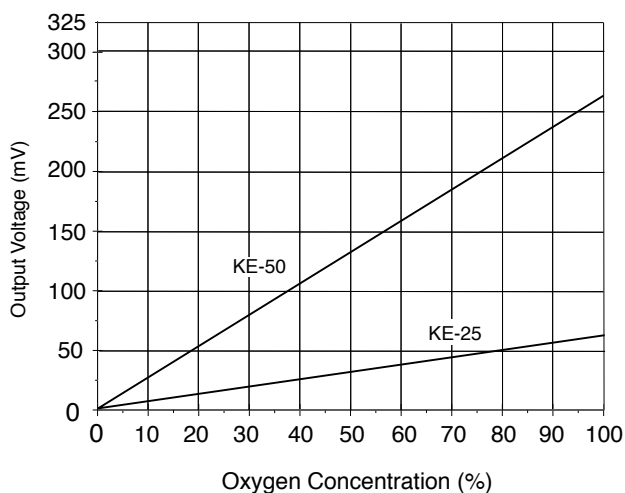

Response time (typical)

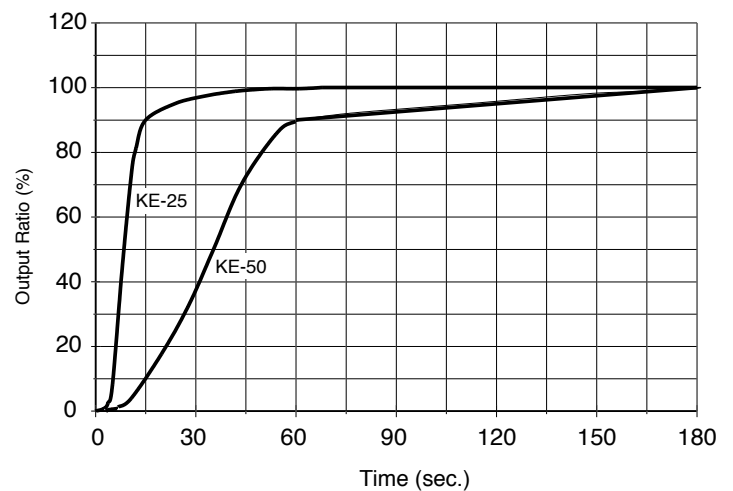

Dimensions

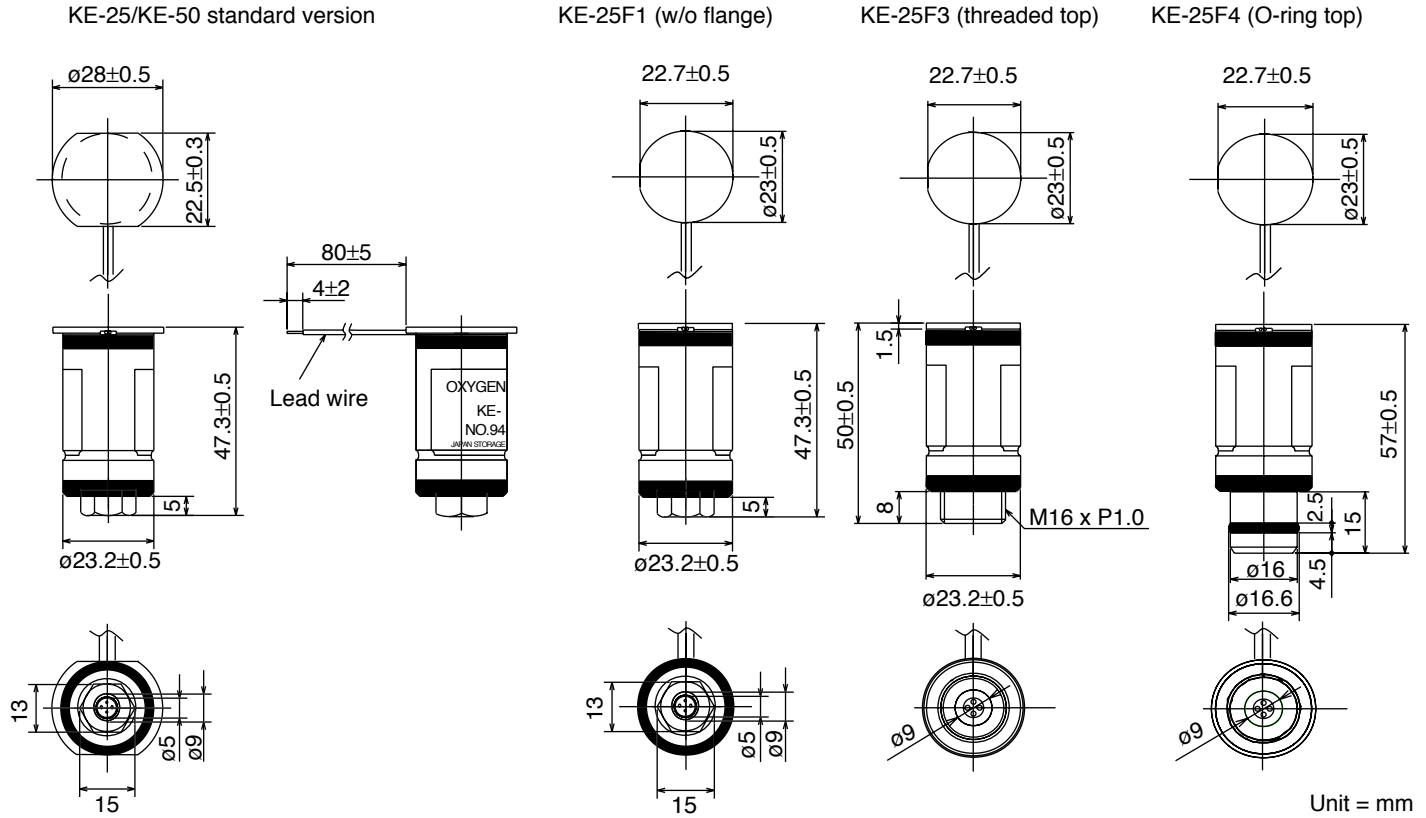

Specifications

Item	Model	
	KE-25	KE-50
Measurement range	0~100% O ₂	
Accuracy (Note 1)	±1% (full scale)	±2% (full scale)
Operating conditions	Atmospheric pressure	811hPa ~1216hPa
	Temperature	5~40°C
	Relative humidity	10 ~ 90%R.H. (no condensation)
Response time (90%) (Note 4)	14±2 seconds	60±5 seconds
Initial output voltage under standard test conditions	10.0~15.5mV	47~65mV
Standard test conditions	Test gas	21% O ₂
	Atmospheric pressure	1013±5hPa
	Temperature	25°C±1°C
	Relative humidity	60±5%
Linearity	(V _a -V ₀)/(V ₁₀₀ -V ₀) (Note 2)	0.21±0.02
Offset voltage	V ₀	≤0.5mV ≤6.0mV
	V _H /V _a	0.91~1.09
Temperature characteristics (Note 3)	V _L /V _a	0.91~1.09

Notes:

1) When calibrated at both 0% and 100% of O₂, accuracy in the range from 0-100% O₂ shall be within ±1% of full scale for KE-25 and ±2% of full scale for KE-50.

2) V_a = output voltage at 21% O₂
V₀ = output voltage at 0% O₂
V₁₀₀ = output voltage at 100% O₂

3) V_a = output voltage at 25°C
V_H = output voltage at 40°C
V_L = output voltage at 5°C

4) Sensors should be used under conditions where the air exchange is greater than 200~300ml per minute in order to obtain the response speed as specified in Table 1.