

## Positive voltage regulators

Datasheet - production data

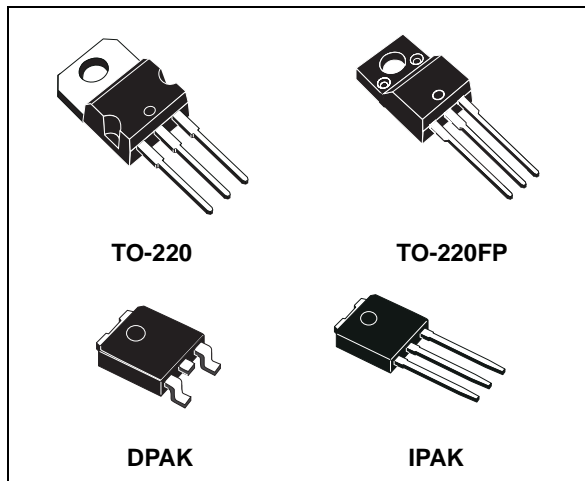

### Description

The L78MxxC series of three-terminal positive regulators is available in TO-220, TO-220FP, DPAK and IPAK packages and with several fixed output voltages, making it useful in a wide range of applications. These regulators can provide local on-card regulation, eliminating the distribution problems associated with single point regulation. Each type employs internal current limiting, thermal shutdown and safe area protection, making it essentially indestructible. If adequate heat sinking is provided, they can deliver over 0.5 A output current. Although designed primarily as fixed voltage regulators, these devices can be used with external components to obtain adjustable voltage and currents.

### Features

- Output current to 0.5 A
- Output voltages of 5; 6; 8; 9; 12; 15; 24 V
- Thermal overload protection
- Short circuit protection
- Output transition SOA protection

**Table 1. Device summary**

Part numbers	Order codes					Output voltages
	TO-220	TO-220 <sup>(1)</sup>	TO-220FP	DPAK	IPAK	
L78M05C	L78M05CV	L78M05CV-DG	L78M05CP	L78M05CDT-TR	L78M05CDT-1	5 V
L78M06C				L78M06CDT-TR		6 V
L78M08C	L78M08CV	L78M08CV-DG		L78M08CDT-TR		8 V
L78M09C	L78M09CV	L78M09CV-DG		L78M09CDT-TR		9 V
L78M12C	L78M12CV	L78M12CV-DG		L78M12CDT-TR		12 V
L78M15C	L78M15CV	L78M15CV-DG		L78M15CDT-TR		15 V
L78M24C	L78M24CV	L78M24CV-DG		L78M24CDT-TR		24 V

1. TO-220 Dual Gauge frame

# 1 Diagram

Figure 1. Block diagram

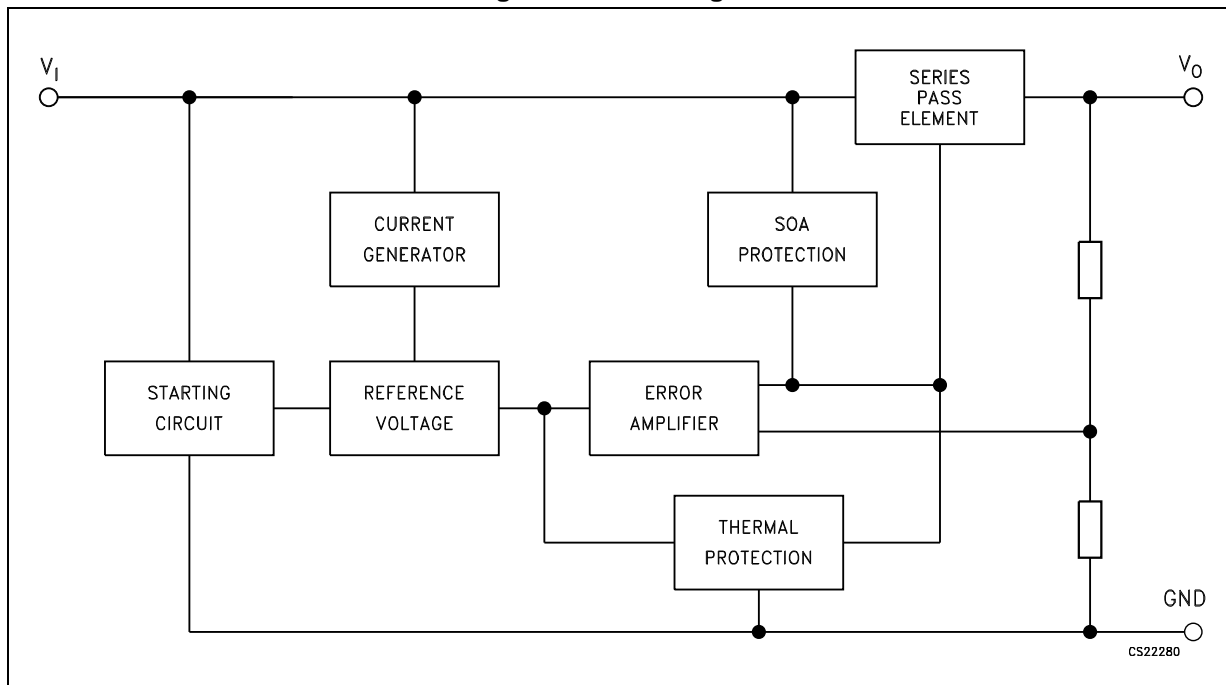

## 2 Pin configuration

Figure 2. Pin connections (top view)

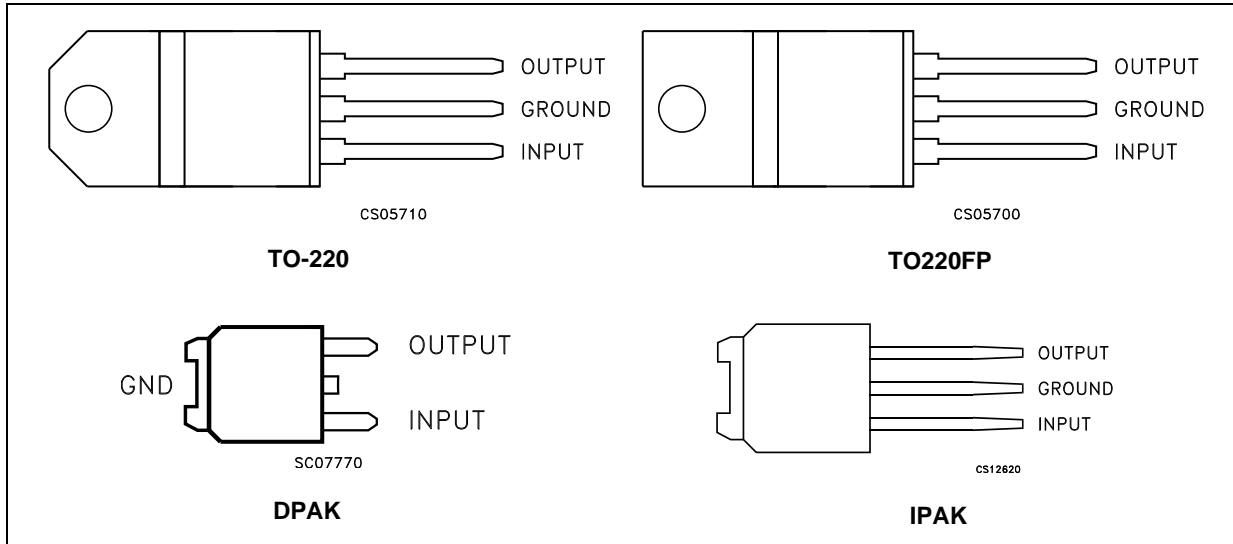
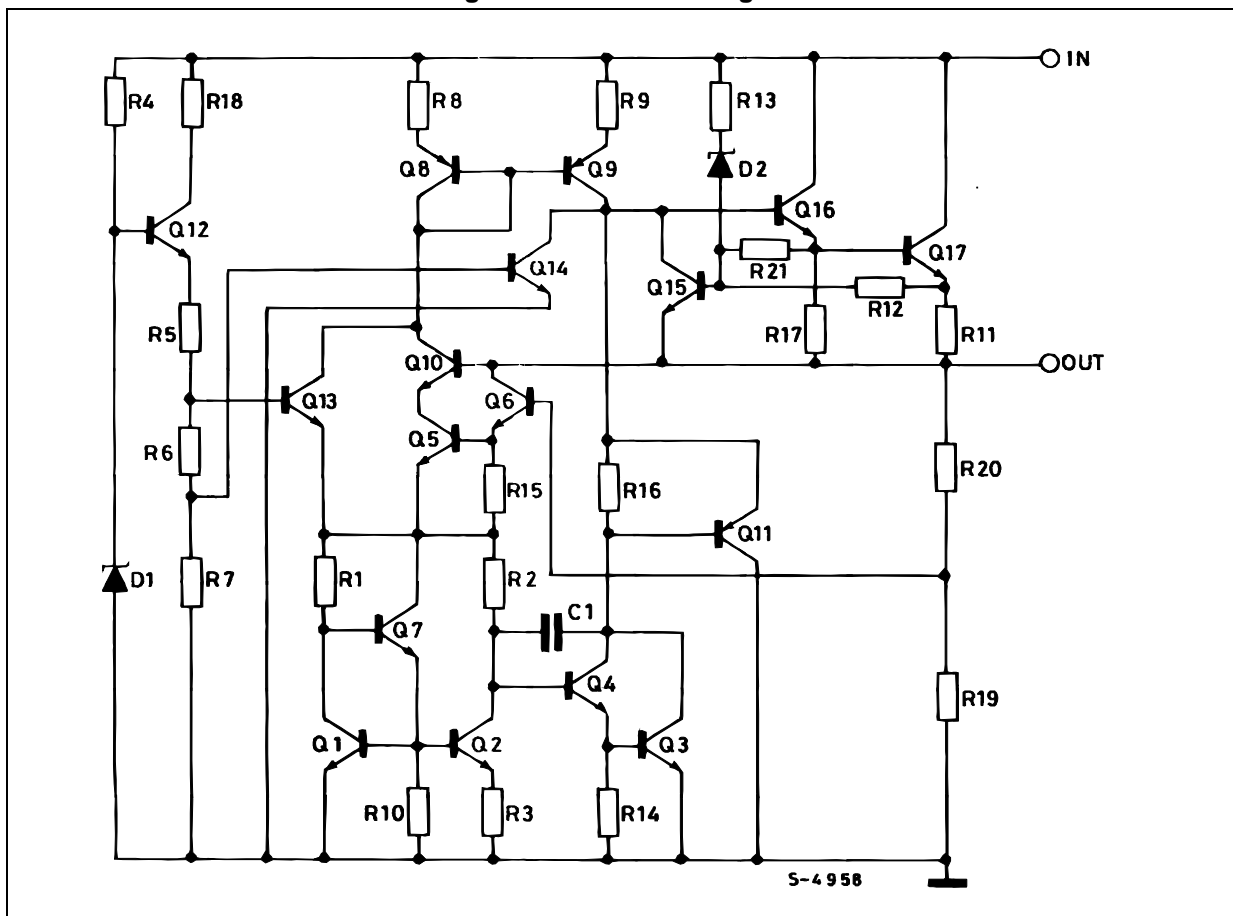

Figure 3. Schematic diagram



### 3 Maximum ratings

Table 2. Absolute maximum ratings

Symbol	Parameter		Value	Unit
$V_I$	DC input voltage	for $V_O = 5$ to $18$ V	35	V
		for $V_O = 20, 24$ V	40	
$I_O$	Output current		Internally limited	mA
$P_D$	Power dissipation		Internally limited	mW
$T_{STG}$	Storage temperature range		- 65 to 150	°C
$T_{OP}$	Operating junction temperature range		0 to 150	°C

Note: Absolute maximum ratings are those values beyond which damage to the device may occur. Functional operation under these condition is not implied.

Table 3. Thermal data

Symbol	Parameter	TO-220	TO-220FP	DPAK	IPAK	Unit
$R_{thJC}$	Thermal resistance junction-case	5	5	8		°C/W
$R_{thJA}$	Thermal resistance junction-ambient	50	60	100		°C/W

Figure 4. Application circuit

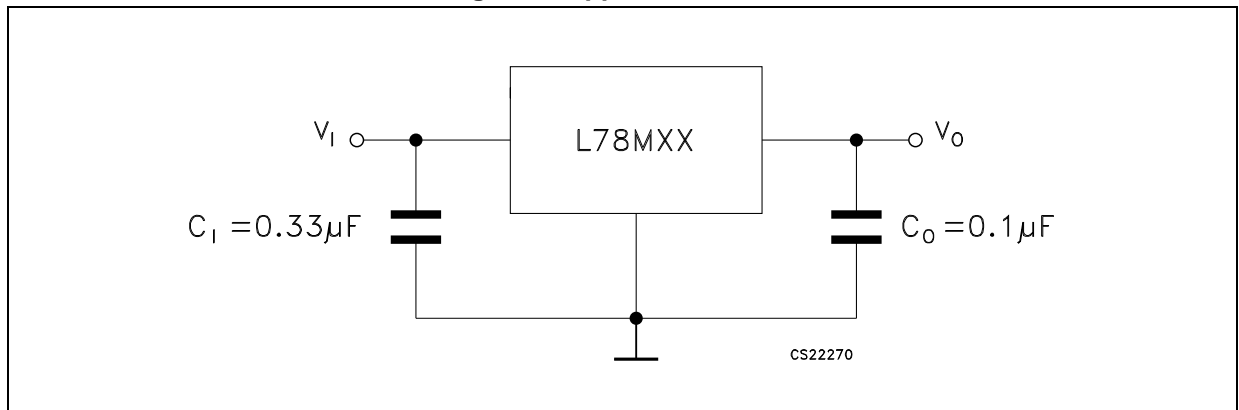

# 4 Test circuits

Figure 5. DC parameter

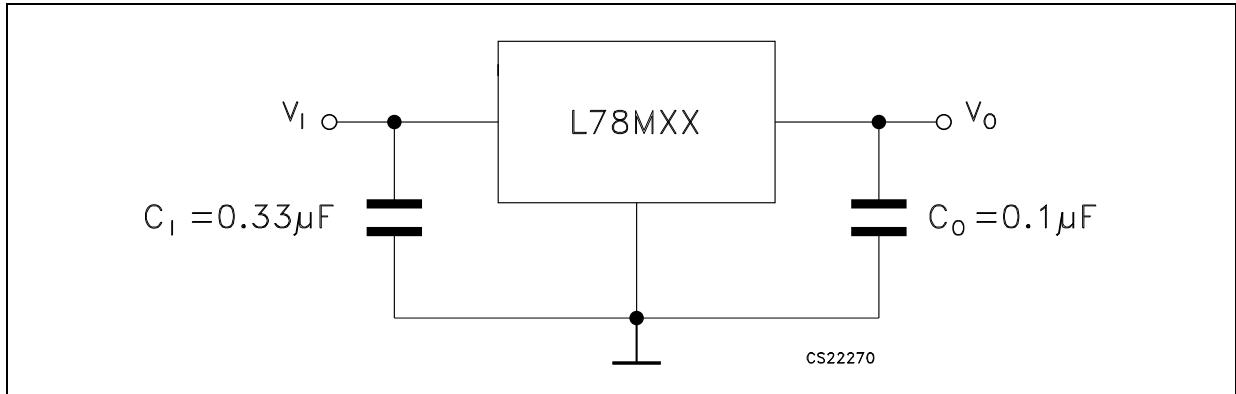

Figure 6. Load regulation

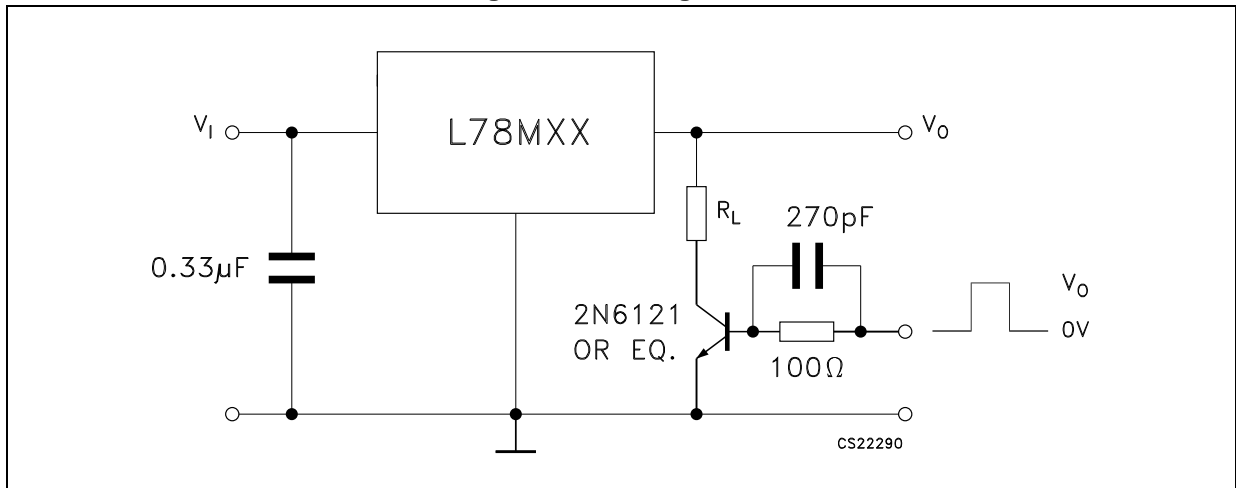
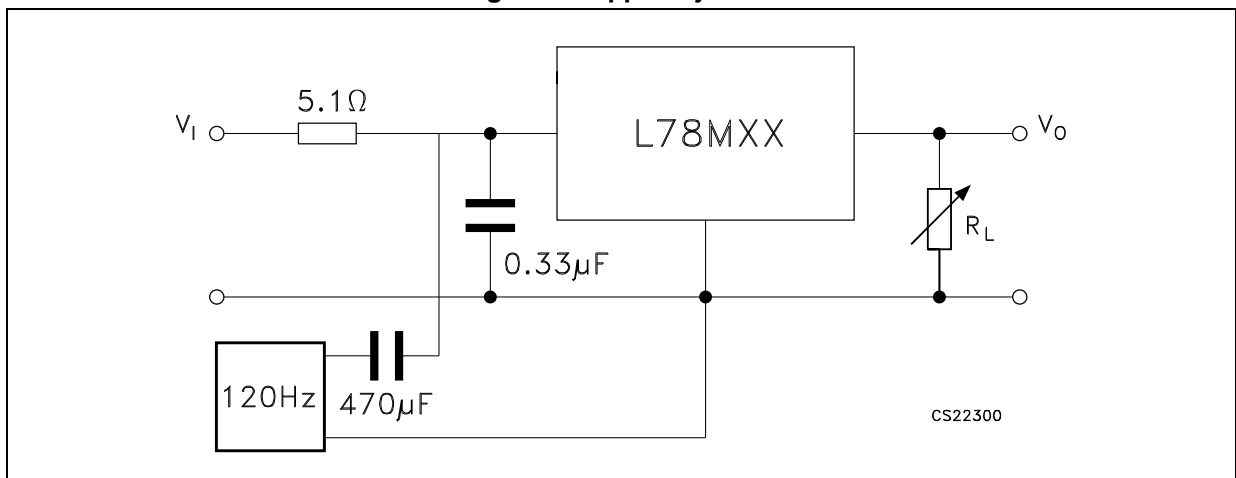

Figure 7. Ripple rejection



## 5 Electrical characteristics

Refer to the test circuits,  $T_J = 25\text{ °C}$ ,  $V_I = 10\text{ V}$ ,  $I_O = 350\text{ mA}$ ,  $C_I = 0.33\text{ }\mu\text{F}$ ,  $C_O = 0.1\text{ }\mu\text{F}$  unless otherwise specified.

**Table 4. Electrical characteristics of L78M05C**

Symbol	Parameter	Test conditions	Min.	Typ.	Max.	Unit
$V_O$	Output voltage		4.8	5	5.2	V
$V_O$	Output voltage	$I_O = 5\text{ to }350\text{ mA}$ , $V_I = 7\text{ to }20\text{ V}$	4.75	5	5.25	V
$\Delta V_O$	Line regulation	$V_I = 7\text{ to }25\text{ V}$ , $I_O = 200\text{ mA}$			100	mV
		$V_I = 8\text{ to }25\text{ V}$ , $I_O = 200\text{ mA}$			50	
$\Delta V_O$	Load regulation	$I_O = 5\text{ to }500\text{ mA}$ , $T_J = 25\text{ °C}$			100	mV
		$I_O = 5\text{ to }200\text{ mA}$ , $T_J = 25\text{ °C}$			50	
$I_d$	Quiescent current				6	mA
$\Delta I_d$	Quiescent current change	$I_O = 5\text{ to }350\text{ mA}$			0.5	mA
		$I_O = 200\text{ mA}$ , $V_I = 8\text{ to }25\text{ V}$			0.8	
$\Delta V_O/\Delta T$	Output voltage drift	$I_O = 5\text{ mA}$ , $T_J = 0\text{ to }125\text{ °C}$		-0.5		mV/°C
SVR	Supply voltage rejection	$V_I = 8\text{ to }18\text{ V}$ , $f = 120\text{ Hz}$ , $I_O = 300\text{ mA}$	62			dB
eN	Output noise voltage	$B = 10\text{ Hz to }100\text{ kHz}$		40		$\mu\text{V}$
$V_d$	Dropout voltage			2		V
$I_{sc}$	Short circuit current	$V_I = 35\text{ V}$		300		mA

Refer to the test circuits,  $T_J = 25\text{ °C}$ ,  $V_I = 11\text{ V}$ ,  $I_O = 350\text{ mA}$ ,  $C_I = 0.33\text{ }\mu\text{F}$ ,  $C_O = 0.1\text{ }\mu\text{F}$  unless otherwise specified.

**Table 5. Electrical characteristics of L78M06C**

Symbol	Parameter	Test conditions	Min.	Typ.	Max.	Unit
$V_O$	Output voltage		5.75	6	6.25	V
$V_O$	Output voltage	$I_O = 5\text{ to }350\text{ mA}$ , $V_I = 8\text{ to }21\text{ V}$	5.7	6	6.3	V
$\Delta V_O$	Line regulation	$V_I = 8\text{ to }25\text{ V}$ , $I_O = 200\text{ mA}$			100	mV
		$V_I = 9\text{ to }25\text{ V}$ , $I_O = 200\text{ mA}$			50	
$\Delta V_O$	Load regulation	$I_O = 5\text{ to }500\text{ mA}$ , $T_J = 25\text{ °C}$			120	mV
		$I_O = 5\text{ to }200\text{ mA}$ , $T_J = 25\text{ °C}$			60	
$I_d$	Quiescent current				6	mA
$\Delta I_d$	Quiescent current change	$I_O = 5\text{ to }350\text{ mA}$			0.5	mA
		$I_O = 200\text{ mA}$ , $V_I = 9\text{ to }25\text{ V}$			0.8	
$\Delta V_O/\Delta T$	Output voltage drift	$I_O = 5\text{ mA}$ , $T_J = 0\text{ to }125\text{ °C}$		-0.5		mV/°C
SVR	Supply voltage rejection	$V_I = 9\text{ to }19\text{ V}$ , $f = 120\text{ Hz}$ , $I_O = 300\text{ mA}$	59			dB
eN	Output noise voltage	$B = 10\text{ Hz to }100\text{ kHz}$		45		$\mu\text{V}$
$V_d$	Dropout voltage			2		V
$I_{sc}$	Short circuit current	$V_I = 35\text{ V}$		270		mA

Refer to the test circuits,  $T_J = 25\text{ °C}$ ,  $V_I = 14\text{ V}$ ,  $I_O = 350\text{ mA}$ ,  $C_I = 0.33\text{ }\mu\text{F}$ ,  $C_O = 0.1\text{ }\mu\text{F}$  unless otherwise specified.

**Table 6. Electrical characteristics of L78M08C**

Symbol	Parameter	Test conditions	Min.	Typ.	Max.	Unit
$V_O$	Output voltage		7.7	8	8.3	V
$V_O$	Output voltage	$I_O = 5\text{ to }350\text{ mA}$ , $V_I = 10.5\text{ to }23\text{ V}$	7.6	8	8.4	V
$\Delta V_O$	Line regulation	$V_I = 10.5\text{ to }25\text{ V}$ , $I_O = 200\text{ mA}$			100	mV
		$V_I = 11\text{ to }25\text{ V}$ , $I_O = 200\text{ mA}$			50	
$\Delta V_O$	Load regulation	$I_O = 5\text{ to }500\text{ mA}$ , $T_J = 25\text{ °C}$			160	mV
		$I_O = 5\text{ to }200\text{ mA}$ , $T_J = 25\text{ °C}$			80	
$I_d$	Quiescent current				6	mA
$\Delta I_d$	Quiescent current change	$I_O = 5\text{ to }350\text{ mA}$			0.5	mA
		$I_O = 200\text{ mA}$ , $V_I = 10.5\text{ to }25\text{ V}$			0.8	
$\Delta V_O/\Delta T$	Output voltage drift	$I_O = 5\text{ mA}$ , $T_J = 0\text{ to }125\text{ °C}$		-0.5		mV/°C
SVR	Supply voltage rejection	$V_I = 11.5\text{ to }21.5\text{ V}$ , $f = 120\text{ Hz}$ , $I_O = 300\text{ mA}$	56			dB
eN	Output noise voltage	$B = 10\text{ Hz to }100\text{ kHz}$		52		$\mu\text{V}$
$V_d$	Dropout voltage			2		V
$I_{sc}$	Short circuit current	$V_I = 35\text{ V}$		250		mA

Refer to the test circuits,  $T_J = 25\text{ °C}$ ,  $V_I = 15\text{ V}$ ,  $I_O = 350\text{ mA}$ ,  $C_I = 0.33\text{ }\mu\text{F}$ ,  $C_O = 0.1\text{ }\mu\text{F}$  unless otherwise specified.

**Table 7. Electrical characteristics of L78M09C**

Symbol	Parameter	Test conditions	Min.	Typ.	Max.	Unit
$V_O$	Output voltage		8.65	9	9.35	V
$V_O$	Output voltage	$I_O = 5\text{ to }350\text{ mA}$ , $V_I = 11.5\text{ to }24\text{ V}$	8.55	9	9.45	V
$\Delta V_O$	Line regulation	$V_I = 11.5\text{ to }25\text{ V}$ , $I_O = 200\text{ mA}$			100	mV
		$V_I = 12\text{ to }25\text{ V}$ , $I_O = 200\text{ mA}$			50	
$\Delta V_O$	Load regulation	$I_O = 5\text{ to }500\text{ mA}$ , $T_J = 25\text{ °C}$			180	mV
		$I_O = 5\text{ to }200\text{ mA}$ , $T_J = 25\text{ °C}$			90	
$I_d$	Quiescent current				6	mA
$\Delta I_d$	Quiescent current change	$I_O = 5\text{ to }350\text{ mA}$			0.5	mA
		$I_O = 200\text{ mA}$ , $V_I = 11.5\text{ to }25\text{ V}$			0.8	
$\Delta V_O/\Delta T$	Output voltage drift	$I_O = 5\text{ mA}$ , $T_J = 0\text{ to }125\text{ °C}$		-0.5		mV/°C
SVR	Supply voltage rejection	$V_I = 12.5\text{ to }23\text{ V}$ , $f = 120\text{ Hz}$ , $I_O = 300\text{ mA}$	56			dB
eN	Output noise voltage	$B = 10\text{ Hz to }100\text{ kHz}$		58		$\mu\text{V}$
$V_d$	Dropout voltage			2		V
$I_{sc}$	Short circuit current	$V_I = 35\text{ V}$		250		mA

Refer to the test circuits,  $T_J = 25\text{ °C}$ ,  $V_I = 19\text{ V}$ ,  $I_O = 350\text{ mA}$ ,  $C_I = 0.33\text{ }\mu\text{F}$ ,  $C_O = 0.1\text{ }\mu\text{F}$  unless otherwise specified.

**Table 8. Electrical characteristics of L78M12C**

Symbol	Parameter	Test conditions	Min.	Typ.	Max.	Unit
$V_O$	Output voltage		11.5	12	12.5	V
$V_O$	Output voltage	$I_O = 5\text{ to }350\text{ mA}$ , $V_I = 14.5\text{ to }27\text{ V}$	11.4	12	12.6	V
$\Delta V_O$	Line regulation	$V_I = 14.5\text{ to }30\text{ V}$ , $I_O = 200\text{ mA}$			100	mV
		$V_I = 16\text{ to }30\text{ V}$ , $I_O = 200\text{ mA}$			50	
$\Delta V_O$	Load regulation	$I_O = 5\text{ to }500\text{ mA}$ , $T_J = 25\text{ °C}$			240	mV
		$I_O = 5\text{ to }200\text{ mA}$ , $T_J = 25\text{ °C}$			120	
$I_d$	Quiescent current				6	mA
$\Delta I_d$	Quiescent current change	$I_O = 5\text{ to }350\text{ mA}$			0.5	mA
		$I_O = 200\text{ mA}$ , $V_I = 14.5\text{ to }30\text{ V}$			0.8	
$\Delta V_O/\Delta T$	Output voltage drift	$I_O = 5\text{ mA}$ , $T_J = 0\text{ to }125\text{ °C}$		-1		mV/°C
SVR	Supply voltage rejection	$V_I = 15\text{ to }25\text{ V}$ , $f = 120\text{ Hz}$ , $I_O = 300\text{ mA}$	55			dB
eN	Output noise voltage	$B = 10\text{ Hz to }100\text{ kHz}$		75		$\mu\text{V}$
$V_d$	Dropout voltage			2		V
$I_{sc}$	Short circuit current	$V_I = 35\text{ V}$		240		mA



Refer to the test circuits,  $T_J = 25\text{ °C}$ ,  $V_I = 23\text{ V}$ ,  $I_O = 350\text{ mA}$ ,  $C_I = 0.33\text{ }\mu\text{F}$ ,  $C_O = 0.1\text{ }\mu\text{F}$  unless otherwise specified.

**Table 9. Electrical characteristics of L78M15C**

Symbol	Parameter	Test conditions	Min.	Typ.	Max.	Unit
$V_O$	Output voltage		14.4	15	15.6	V
$V_O$	Output voltage	$I_O = 5\text{ to }350\text{ mA}$ , $V_I = 17.5\text{ to }30\text{ V}$	14.25	15	15.75	V
$\Delta V_O$	Line regulation	$V_I = 17.5\text{ to }30\text{ V}$ , $I_O = 200\text{ mA}$			100	mV
		$V_I = 20\text{ to }30\text{ V}$ , $I_O = 200\text{ mA}$			50	
$\Delta V_O$	Load regulation	$I_O = 5\text{ to }500\text{ mA}$ , $T_J = 25\text{ °C}$			300	mV
		$I_O = 5\text{ to }200\text{ mA}$ , $T_J = 25\text{ °C}$			150	
$I_d$	Quiescent current				6	mA
$\Delta I_d$	Quiescent current change	$I_O = 5\text{ to }350\text{ mA}$			0.5	mA
		$I_O = 200\text{ mA}$ , $V_I = 17.5\text{ to }30\text{ V}$			0.8	
$\Delta V_O/\Delta T$	Output voltage drift	$I_O = 5\text{ mA}$ , $T_J = 0\text{ to }125\text{ °C}$		-1		mV/°C
SVR	Supply voltage rejection	$V_I = 18.5\text{ to }28.5\text{ V}$ , $f = 120\text{ Hz}$ , $I_O = 300\text{ mA}$	54			dB
eN	Output noise voltage	$B = 10\text{ Hz to }100\text{ kHz}$		90		$\mu\text{V}$
$V_d$	Dropout voltage			2		V
$I_{sc}$	Short circuit current	$V_I = 35\text{ V}$		240		mA

Refer to the test circuits,  $T_J = 25\text{ °C}$ ,  $V_I = 23\text{ V}$ ,  $I_O = 350\text{ mA}$ ,  $C_I = 0.33\text{ }\mu\text{F}$ ,  $C_O = 0.1\text{ }\mu\text{F}$  unless otherwise specified.

**Table 10. Electrical characteristics of L78M24C**

Symbol	Parameter	Test conditions	Min.	Typ.	Max.	Unit
$V_O$	Output voltage		23	24	25	V
$V_O$	Output voltage	$I_O = 5\text{ to }350\text{ mA}$ , $V_I = 27\text{ to }38\text{ V}$	22.8	24	25.2	V
$\Delta V_O$	Line regulation	$V_I = 27\text{ to }38\text{ V}$ , $I_O = 200\text{ mA}$			100	mV
		$V_I = 28\text{ to }38\text{ V}$ , $I_O = 200\text{ mA}$			50	
$\Delta V_O$	Load regulation	$I_O = 5\text{ to }500\text{ mA}$ , $T_J = 25\text{ °C}$			480	mV
		$I_O = 5\text{ to }200\text{ mA}$ , $T_J = 25\text{ °C}$			240	
$I_d$	Quiescent current				6	mA
$\Delta I_d$	Quiescent current change	$I_O = 5\text{ to }350\text{ mA}$			0.5	mA
		$I_O = 200\text{ mA}$ , $V_I = 27\text{ to }38\text{ V}$			0.8	
$\Delta V_O/\Delta T$	Output voltage drift	$I_O = 5\text{ mA}$ , $T_J = 0\text{ to }125\text{ °C}$		-1.2		mV/°C
SVR	Supply voltage rejection	$V_I = 28\text{ to }38\text{ V}$ , $f = 120\text{ Hz}$ , $I_O = 300\text{ mA}$	50			dB
eN	Output noise voltage	$B = 10\text{ Hz to }100\text{ kHz}$		170		$\mu\text{V}$
$V_d$	Dropout voltage			2		V
$I_{sc}$	Short circuit current	$V_I = 35\text{ V}$		240		mA

## 6 Typical performance

Figure 8. Dropout voltage vs. junction temp.

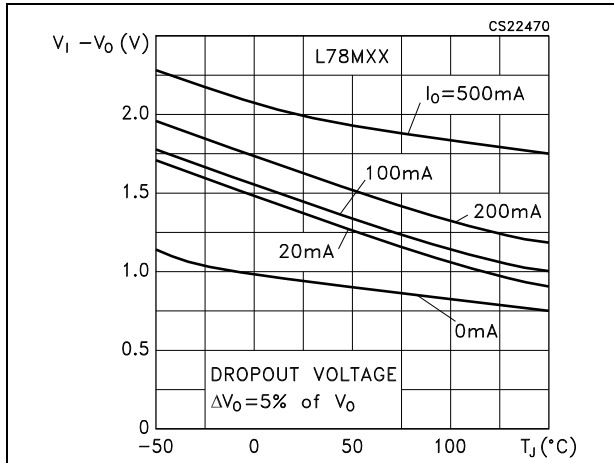

Figure 9. Dropout characteristics

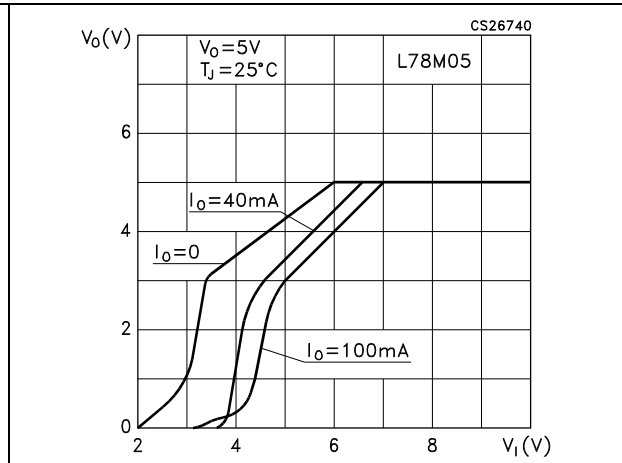

Figure 10. Peak output current vs. input-output differential voltage

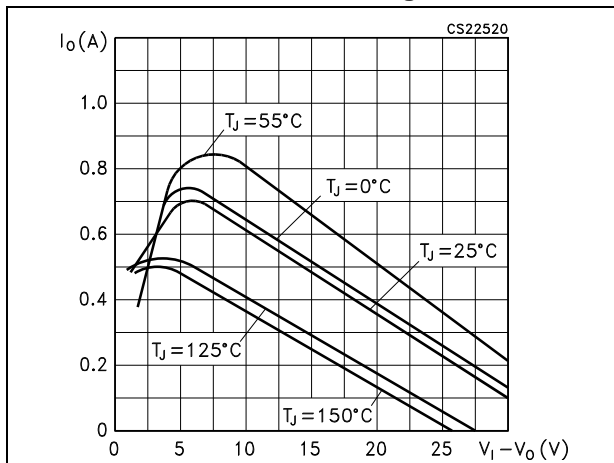

Figure 11. Output voltage vs. junction temperature

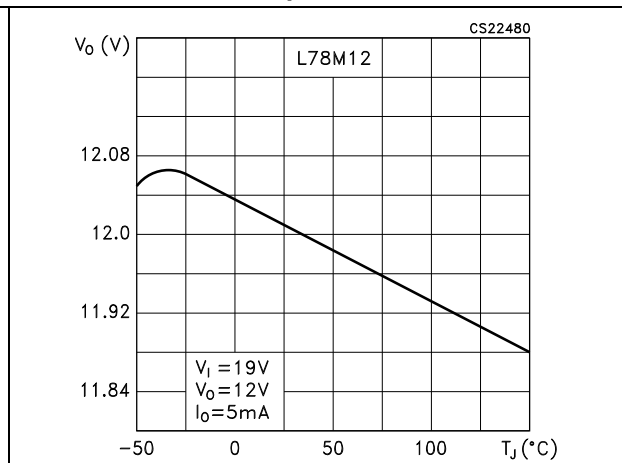

Figure 12. Supply voltage rejection vs. frequency

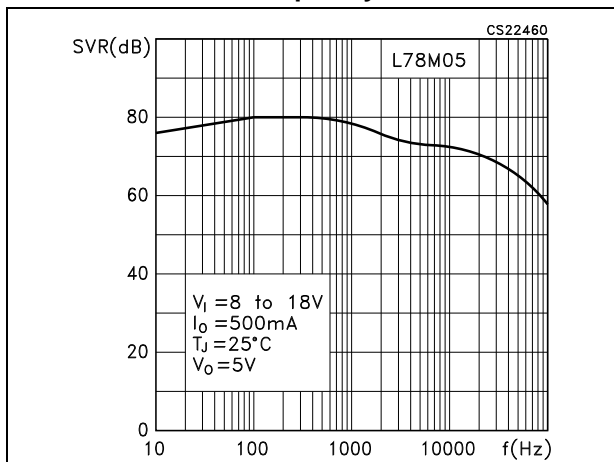

Figure 13. Quiescent current vs. junction temperature

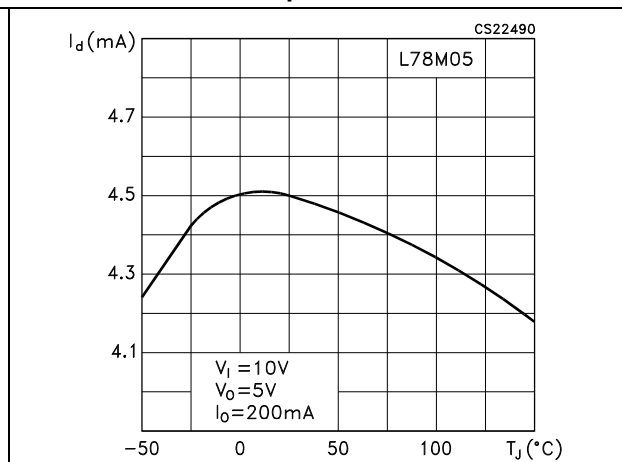

Figure 14. Load transient response

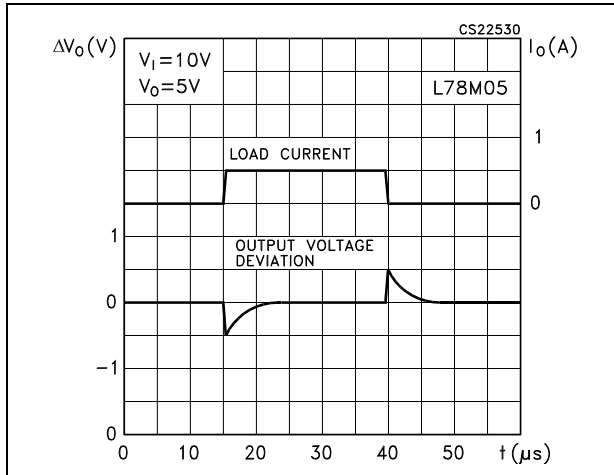

Figure 15. Line transient response

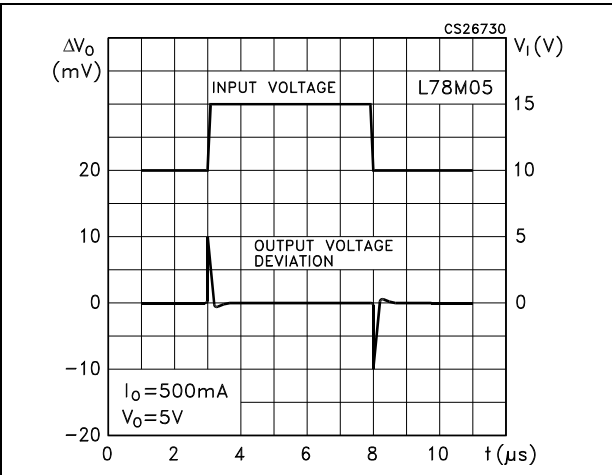

Figure 16. Quiescent current vs. input voltage

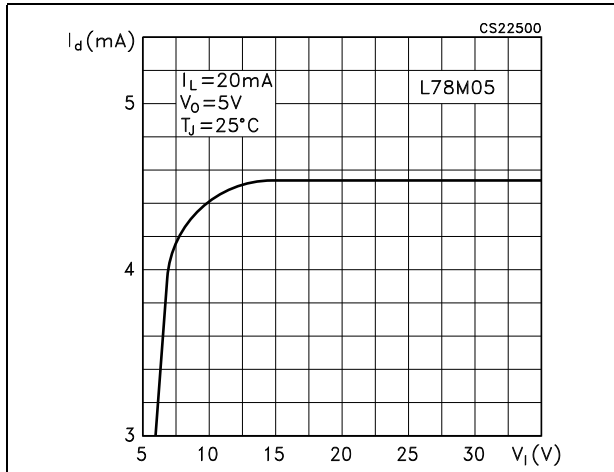
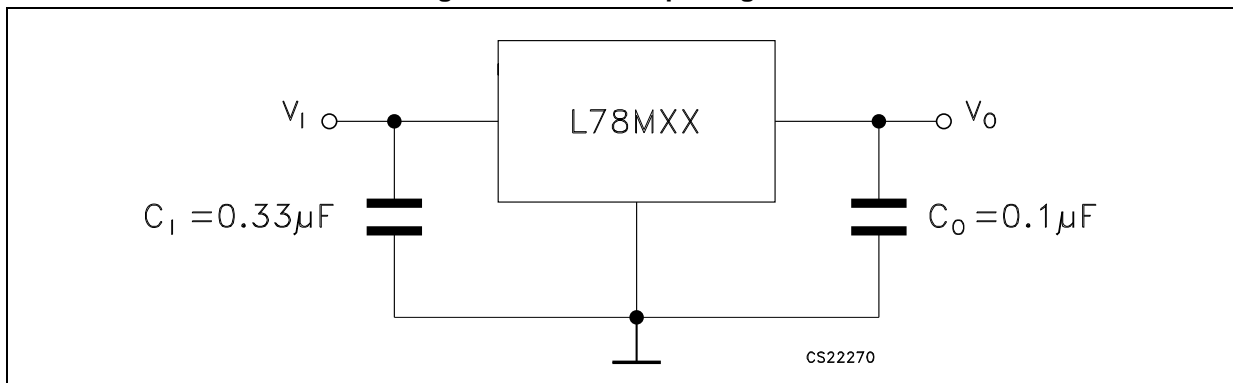

Figure 17. Fixed output regulator



1. To specify an output voltage, substitute voltage value for "XX".
2. Although no output capacitor is needed for stability, it does improve transient response.
3. Required if regulator is located an appreciable distance from power supply filter.

Figure 18. Constant current regulator

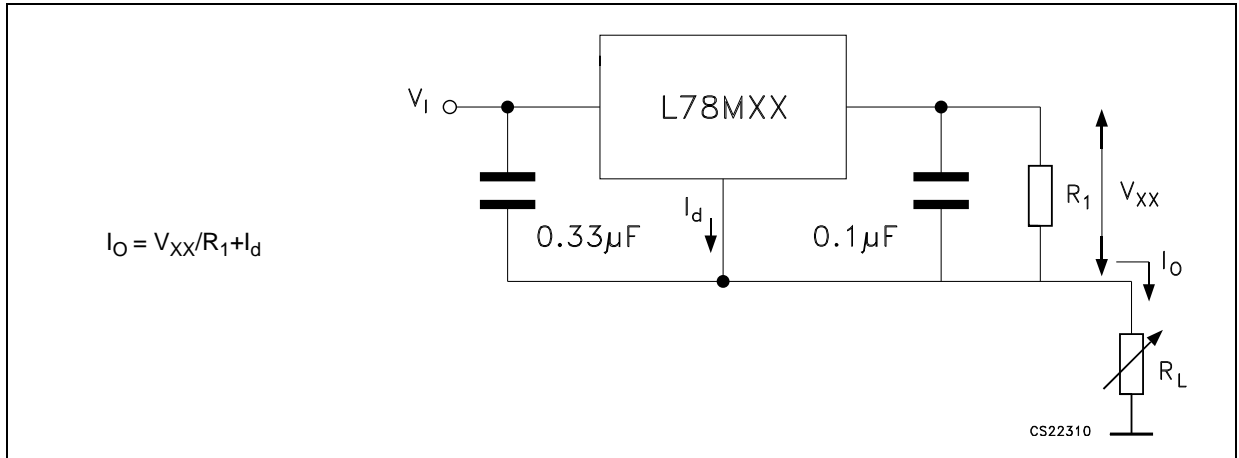

Figure 19. Circuit for increasing output voltage

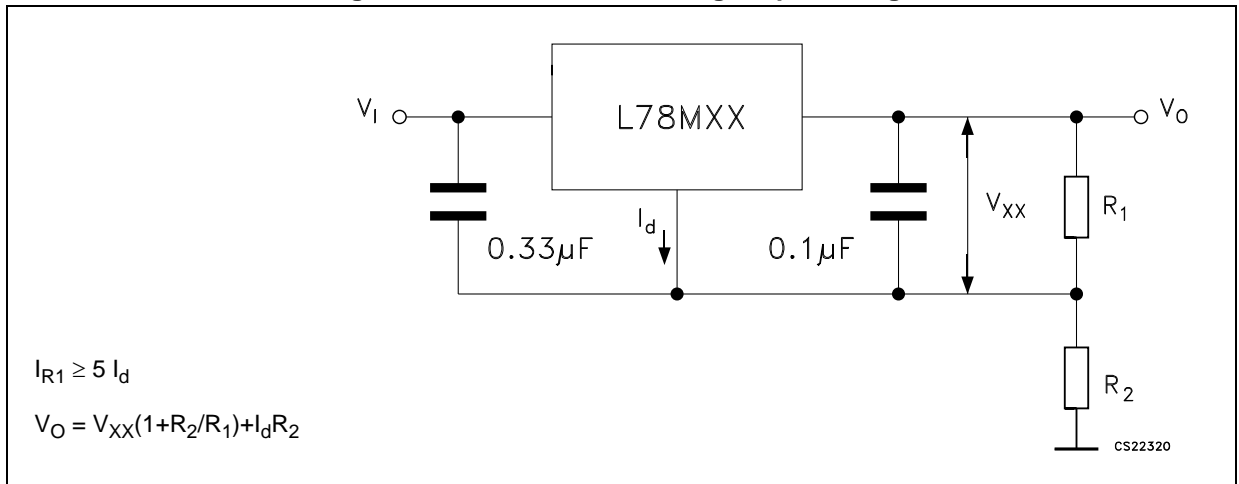

Figure 20. Adjustable output regulator (7 to 30 V)

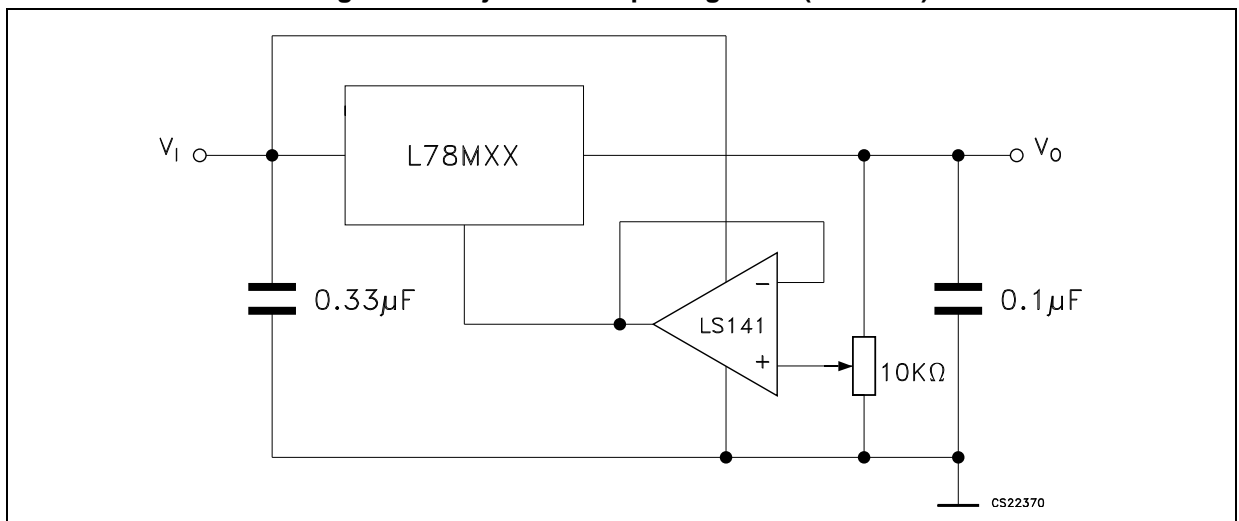

Figure 21. 0.5 to 10 V regulator

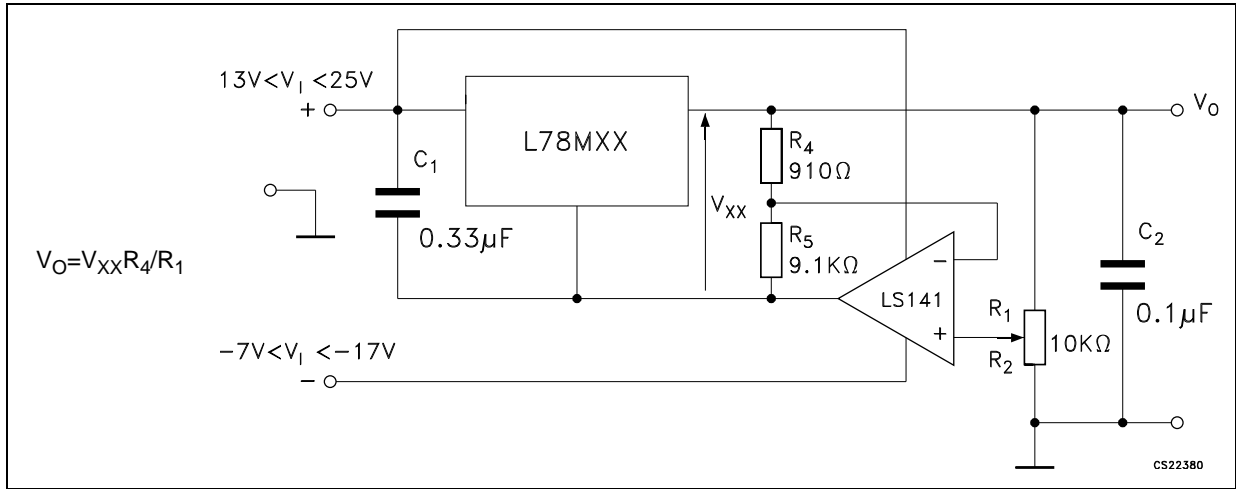

Figure 22. High current voltage regulator

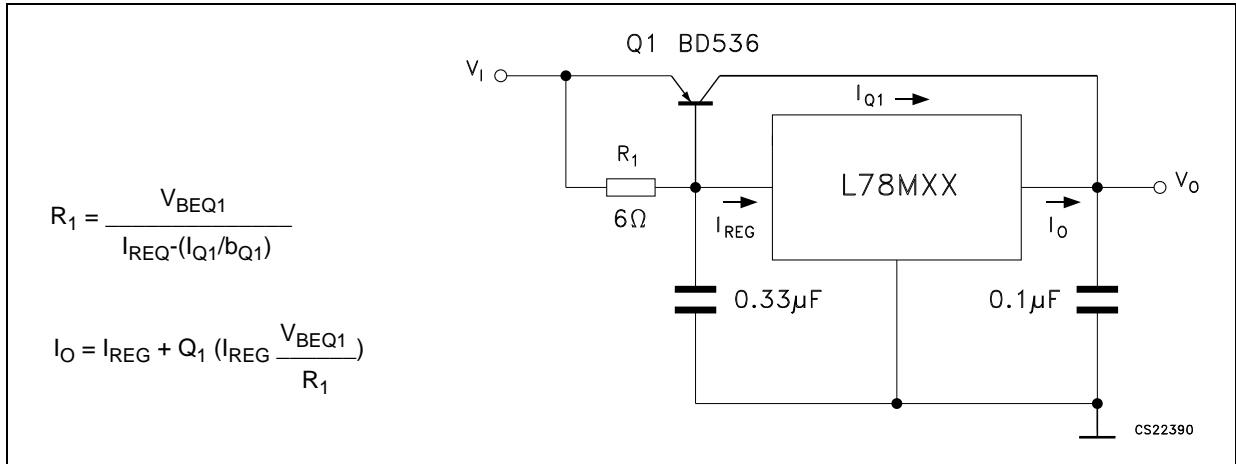

Figure 23. High output current with short circuit protection

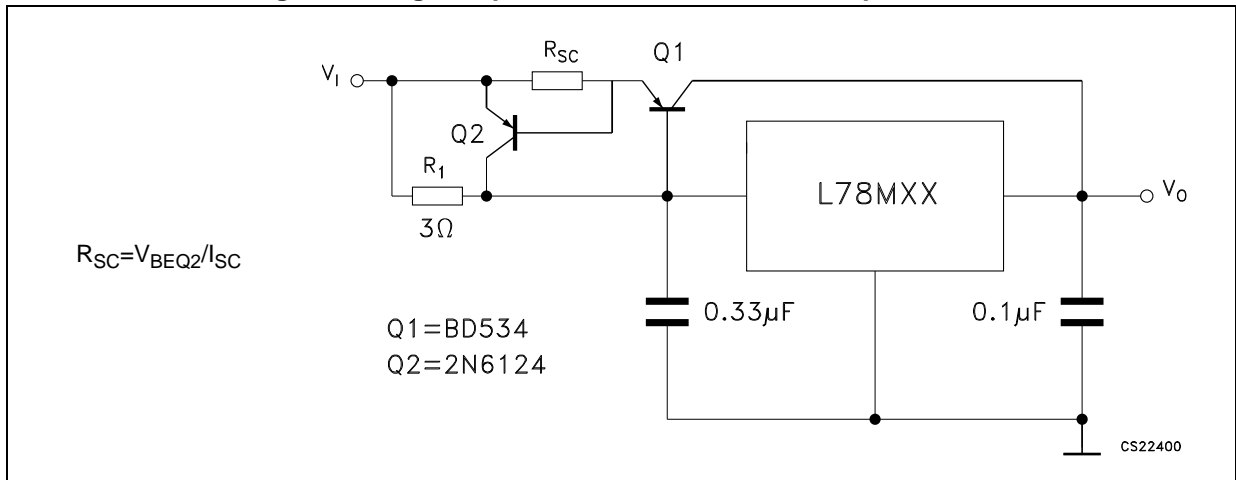

Figure 24. Tracking voltage regulator

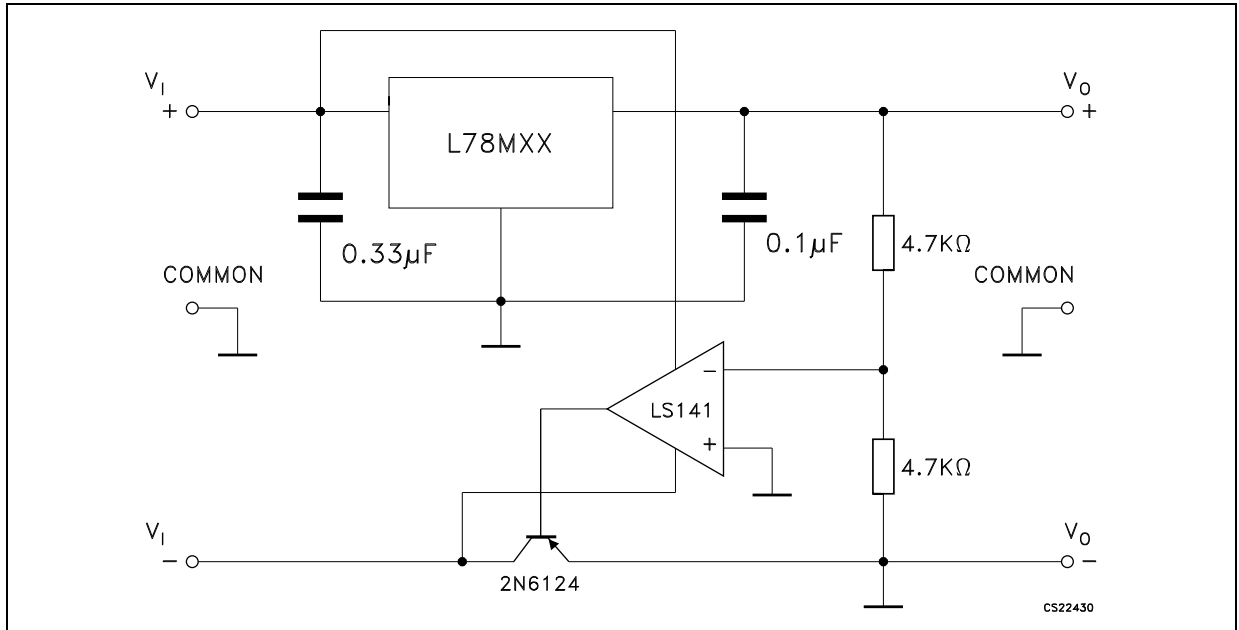

Figure 25. High input voltage circuit

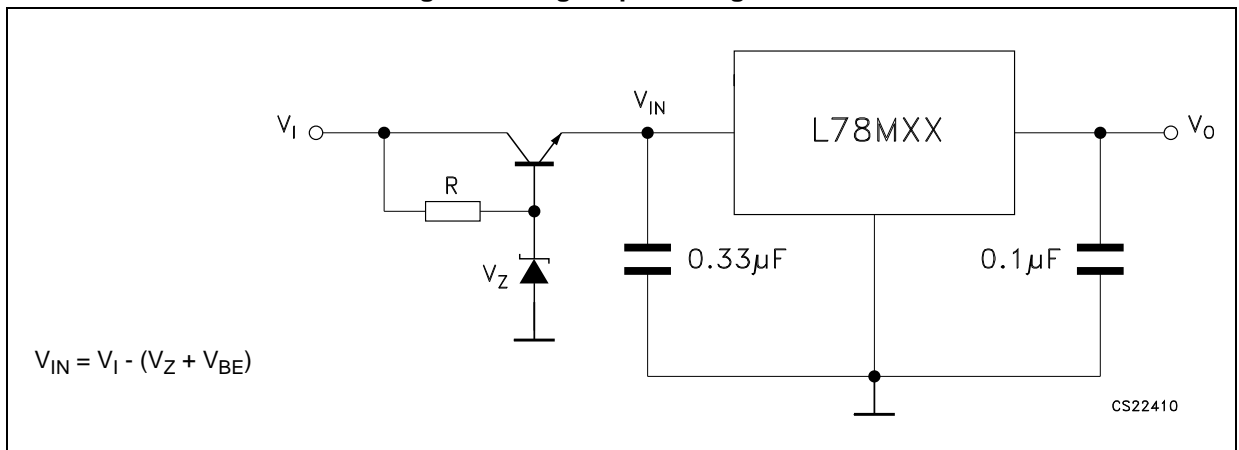

Figure 26. Reducing power dissipation with dropping resistor

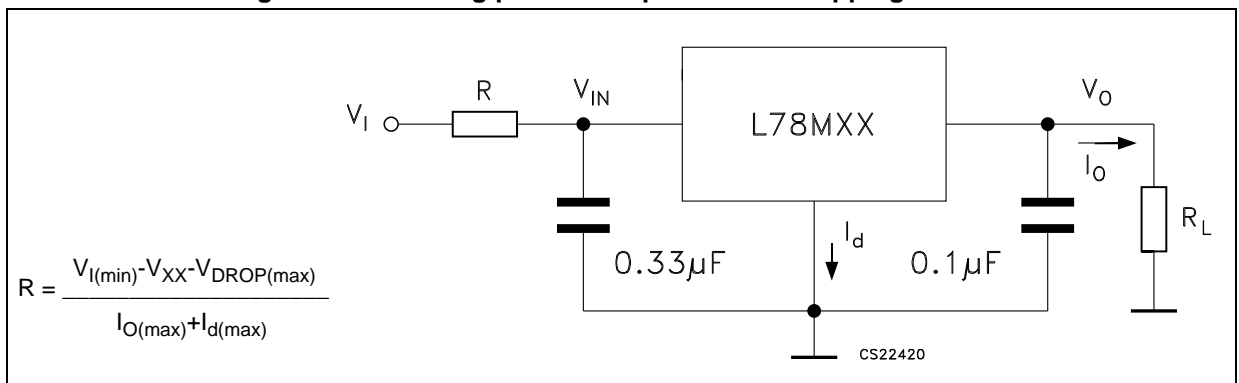
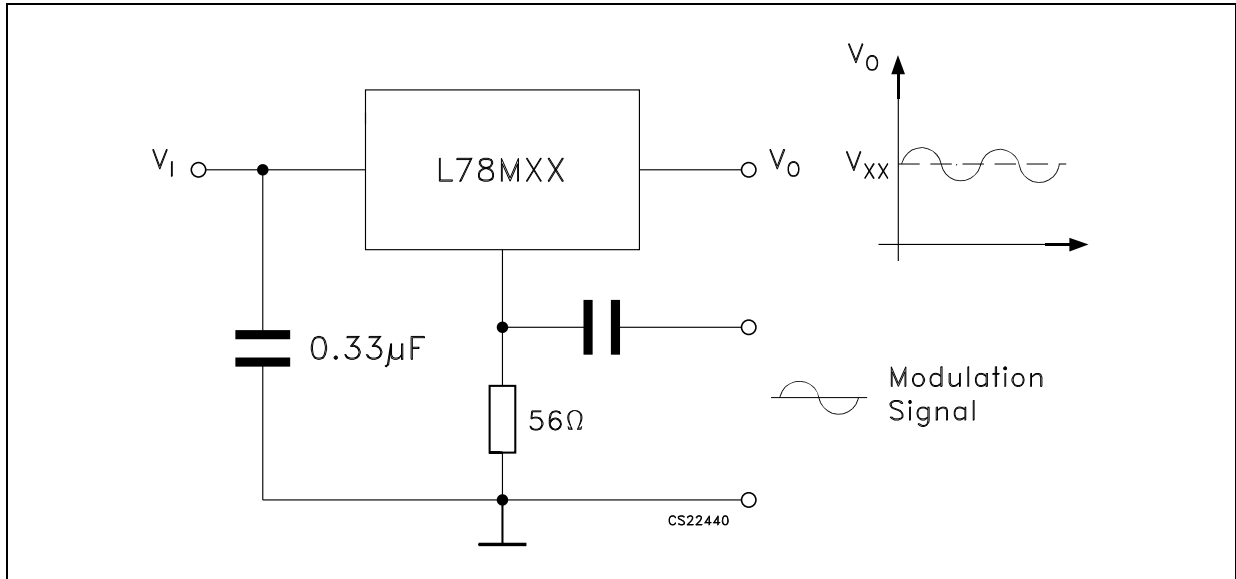
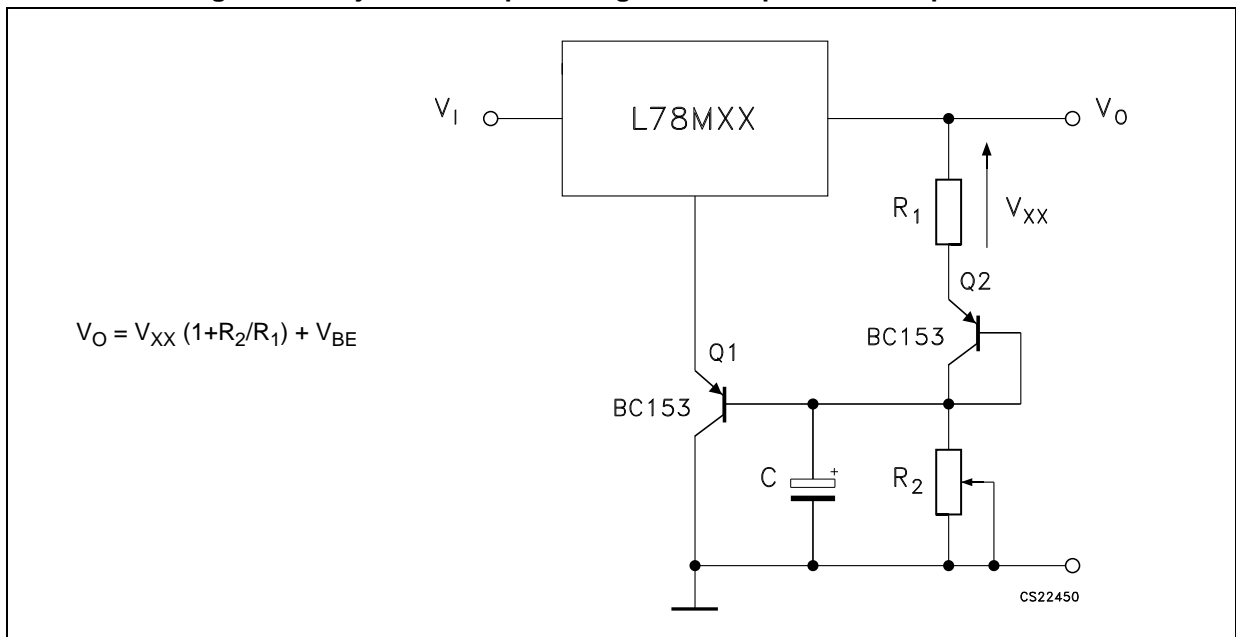

Figure 27. Power AM modulator (unity voltage gain,  $I_O \leq 0.5$ )



Note: The circuit performs well up to 100 kHz.

Figure 28. Adjustable output voltage with temperature compensation



Note:  $Q_2$  is connected as a diode in order to compensate the variation of the  $Q_1 V_{BE}$  with the temperature.  $C$  allows a slow rise time of the  $V_O$ .

## 7 Package mechanical data

In order to meet environmental requirements, ST offers these devices in different grades of ECOPACK<sup>®</sup> packages, depending on their level of environmental compliance. ECOPACK<sup>®</sup> specifications, grade definitions and product status are available at: [www.st.com](http://www.st.com). ECOPACK is an ST trademark.

Table 11. TO-220 mechanical data

Dim.	Type STD - ST Dual Gauge			Type STD - ST Single Gauge		
	mm.			mm.		
	Min.	Typ.	Max.	Min.	Typ.	Max.
A	4.40		4.60	4.40		4.60
b	0.61		0.88	0.61		0.88
b1	1.14		1.70	1.14		1.70
c	0.48		0.70	0.48		0.70
D	15.25		15.75	15.25		15.75
D1		1.27				
E	10.00		10.40	10.00		10.40
e	2.40		2.70	2.40		2.70
e1	4.95		5.15	4.95		5.15
F	1.23		1.32	0.51		0.60
H1	6.20		6.60	6.20		6.60
J1	2.40		2.72	2.40		2.72
L	13.00		14.00	13.00		14.00
L1	3.50		3.93	3.50		3.93
L20		16.40			16.40	
L30		28.90			28.90	
∅P	3.75		3.85	3.75		3.85
Q	2.65		2.95	2.65		2.95

*In spite of some difference in tolerances, the packages are compatible.*



Figure 29. Drawing dimension TO-220 (type STD-ST Dual Gauge)

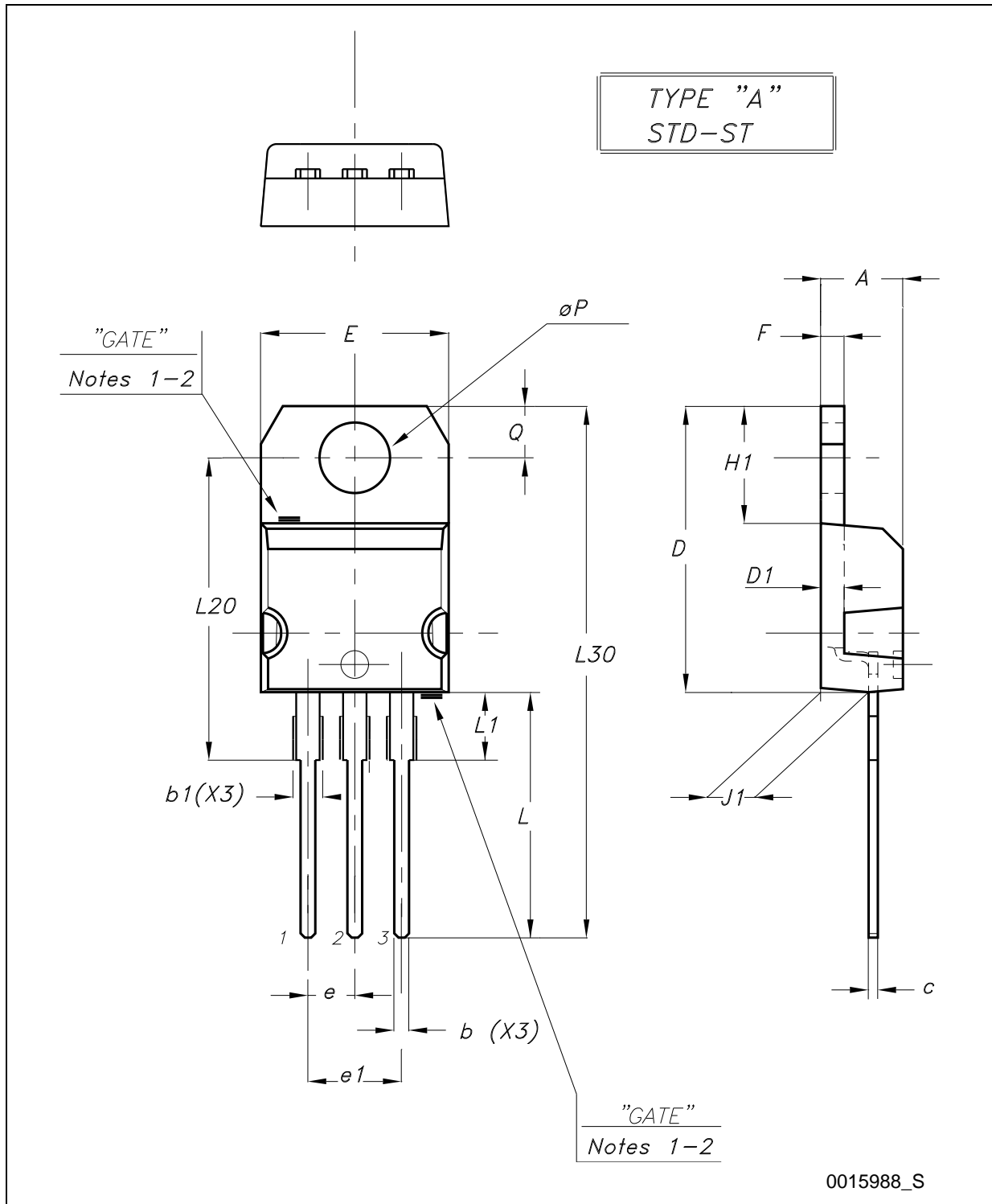

- Note: 1 Maximum resin gate protrusion: 0.5 mm.  
 2 Resin gate position is accepted in each of the two positions shown on the drawing, or their symmetrical.

Figure 30. Drawing dimension TO-220 (type STD-ST Single Gauge)

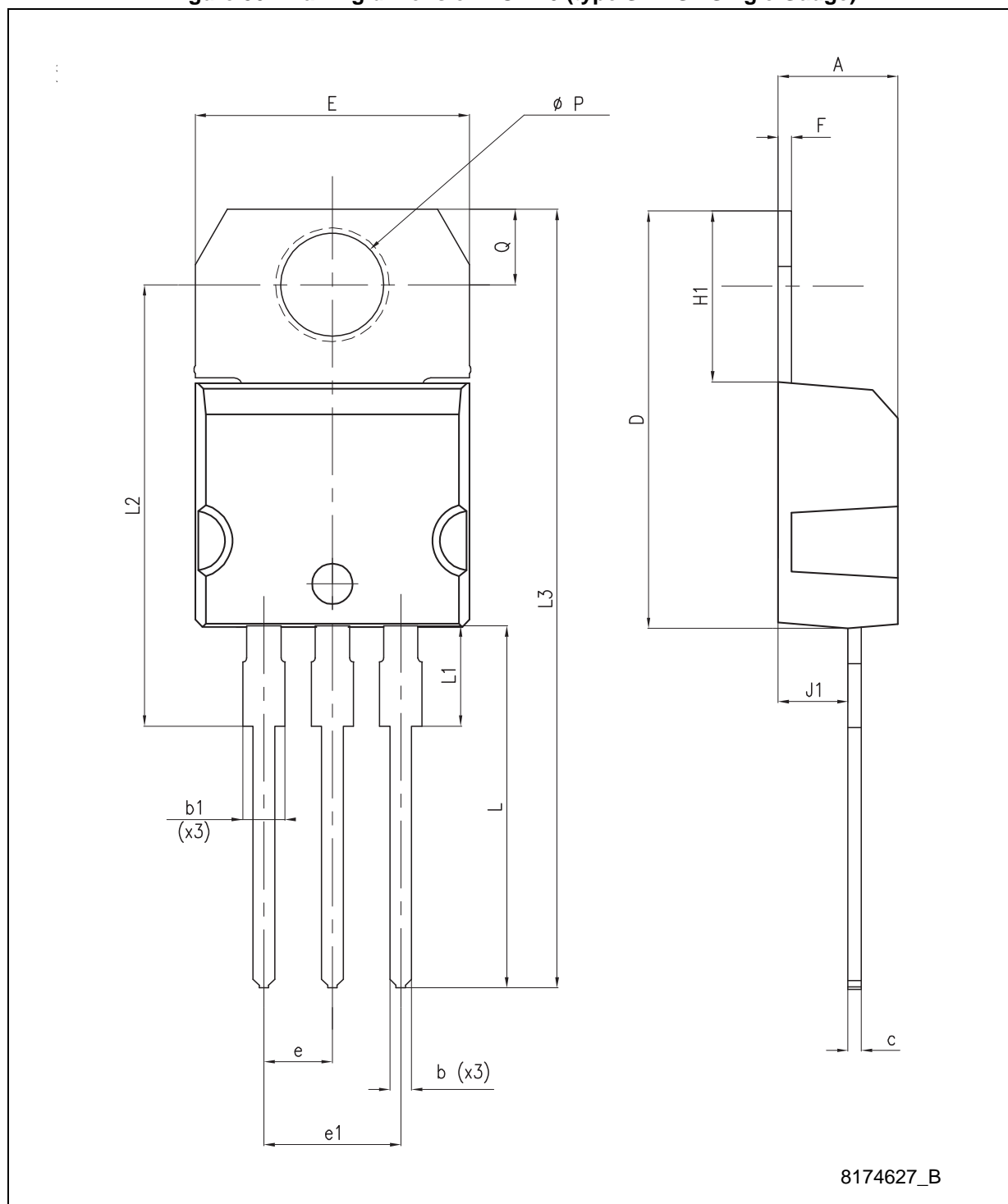

Figure 31. Drawing dimension tube for TO-220 Dual Gauge (mm.)

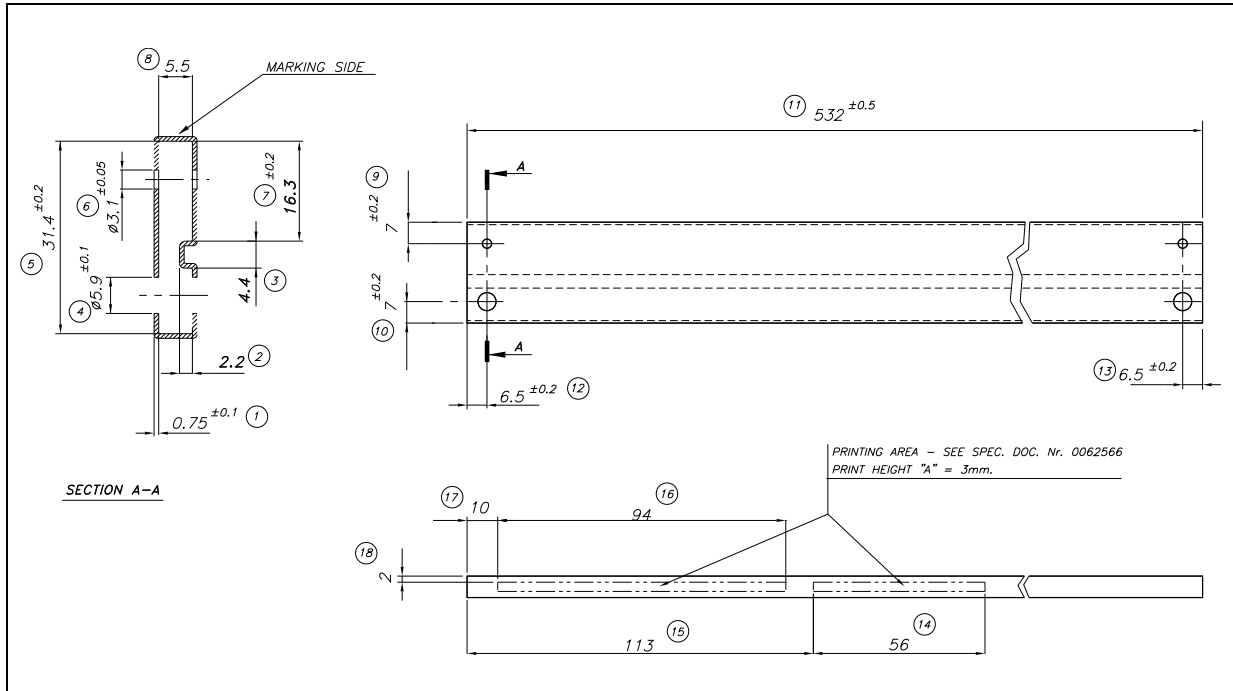
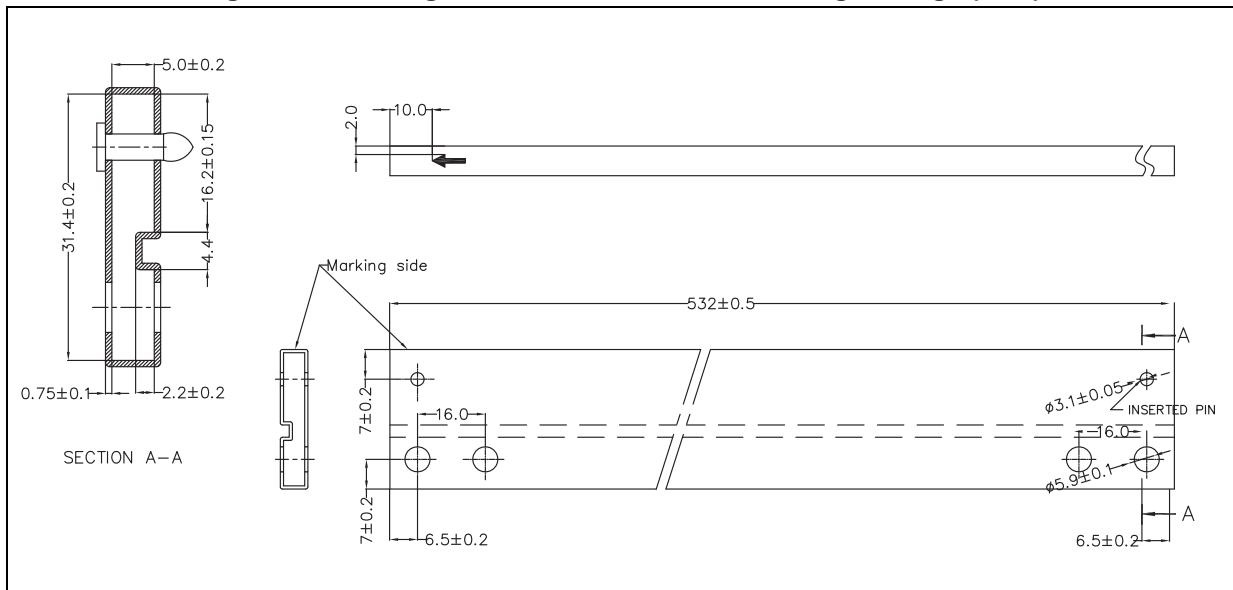

Figure 32. Drawing dimension tube for TO-220 Single Gauge (mm.)



**TO-220FP mechanical data**

Dim.	mm.			inch.		
	Min.	Typ	Max.	Min.	Typ.	Max.
A	4.40		4.60	0.173		0.181
B	2.5		2.7	0.098		0.106
D	2.5		2.75	0.098		0.108
E	0.45		0.70	0.017		0.027
F	0.75		1	0.030		0.039
F1	1.15		1.50	0.045		0.059
F2	1.15		1.50	0.045		0.059
G	4.95		5.2	0.194		0.204
G1	2.4		2.7	0.094		0.106
H	10.0		10.40	0.393		0.409
L2		16			0.630	
L3	28.6		30.6	1.126		1.204
L4	9.8		10.6	0.385		0.417
L5	2.9		3.6	0.114		0.142
L6	15.9		16.4	0.626		0.645
L7	9		9.3	0.354		0.366
DIA.	3		3.2	0.118		0.126

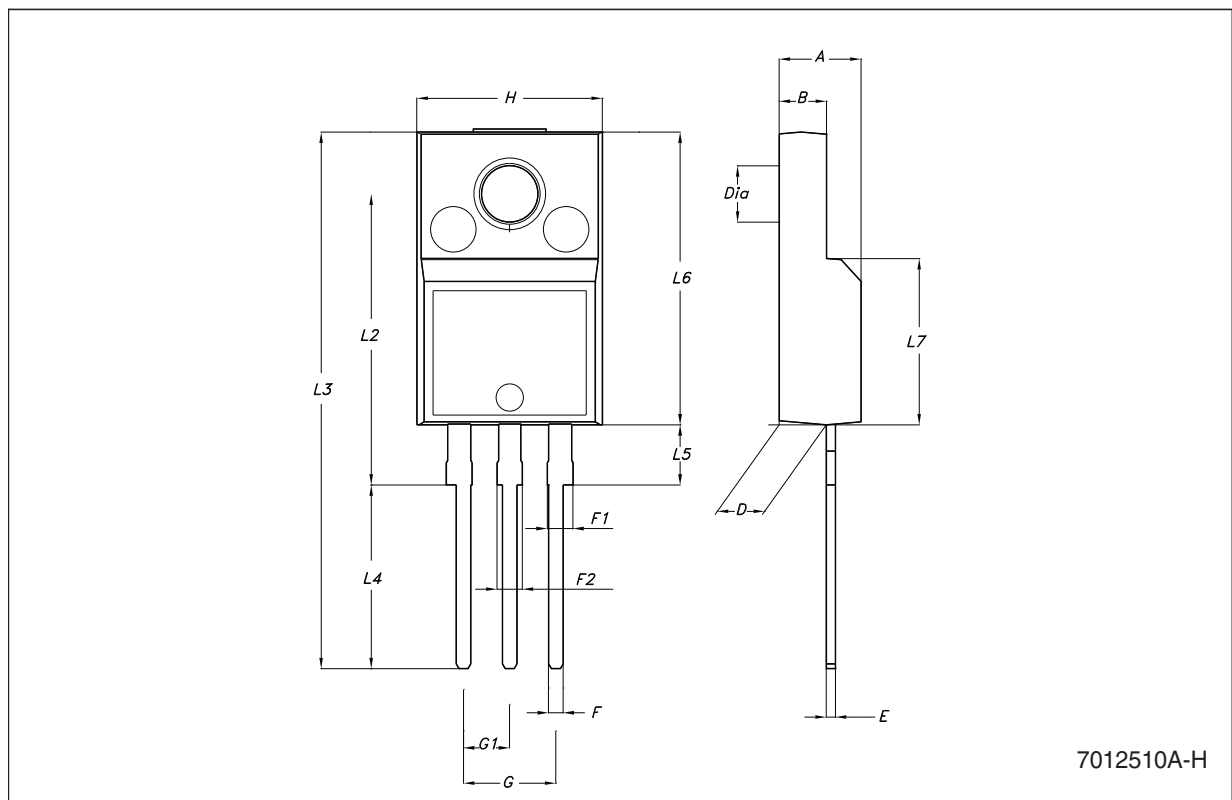
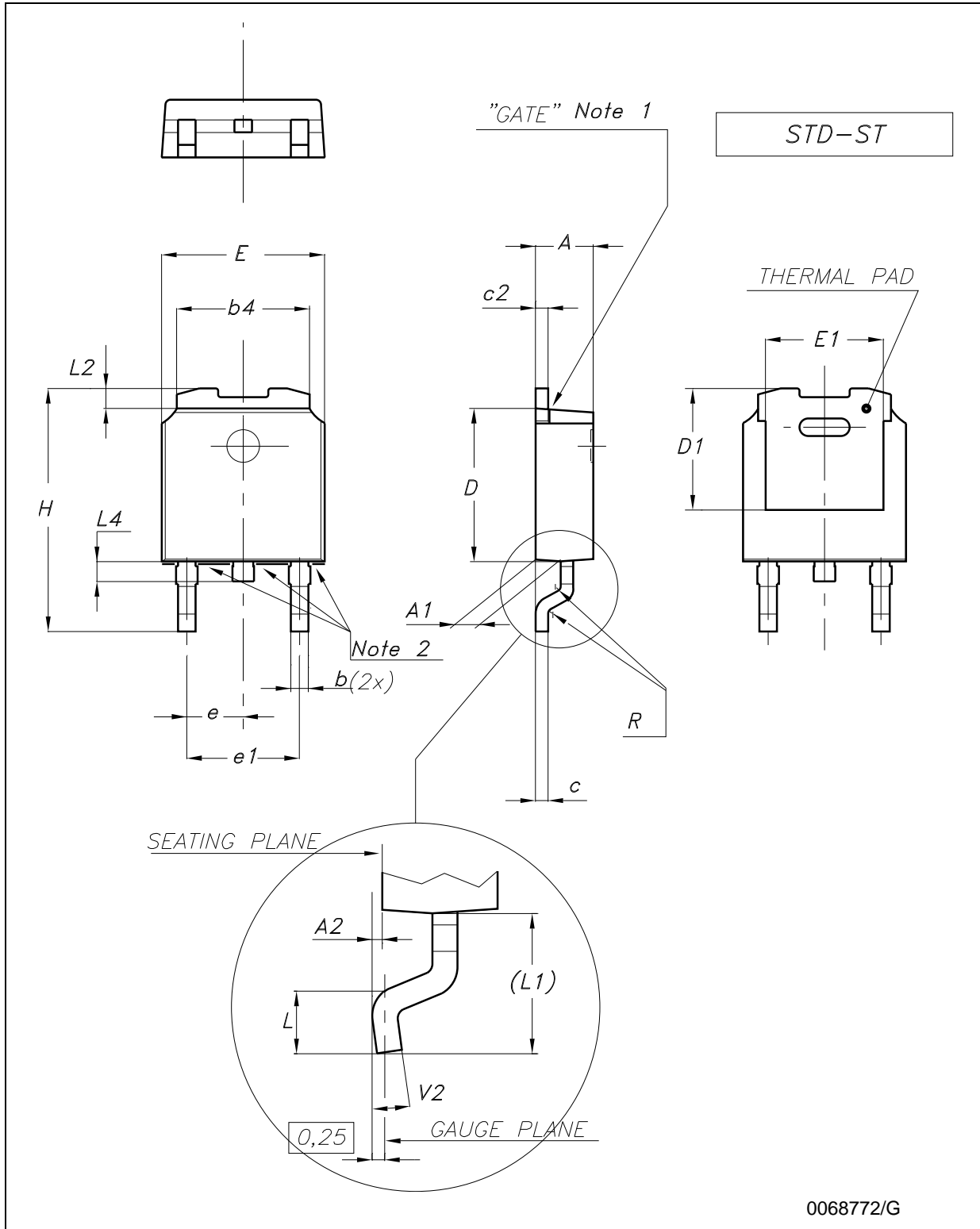

Figure 33. Drawing dimension DPAK (type STD-ST)



Note: 1 Max resin gate protrusion: 0.5 mm.

2 Max resin protrusion: 0.25 mm.

Figure 34. Drawing dimension DPAK (type FUJITSU-subcon.)

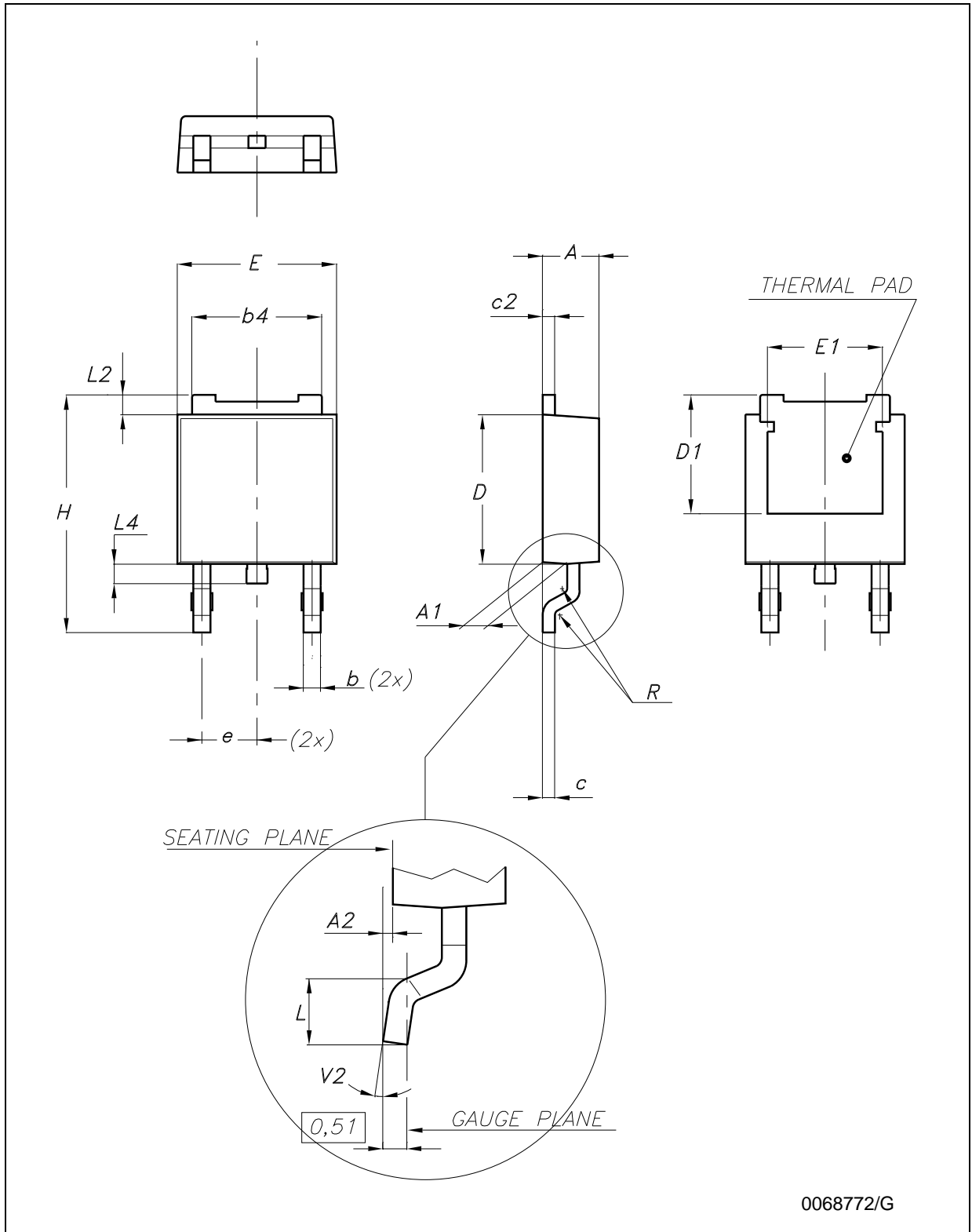

0068772/G

Figure 35. Drawing dimension DPAK (type IDS-subcon.)

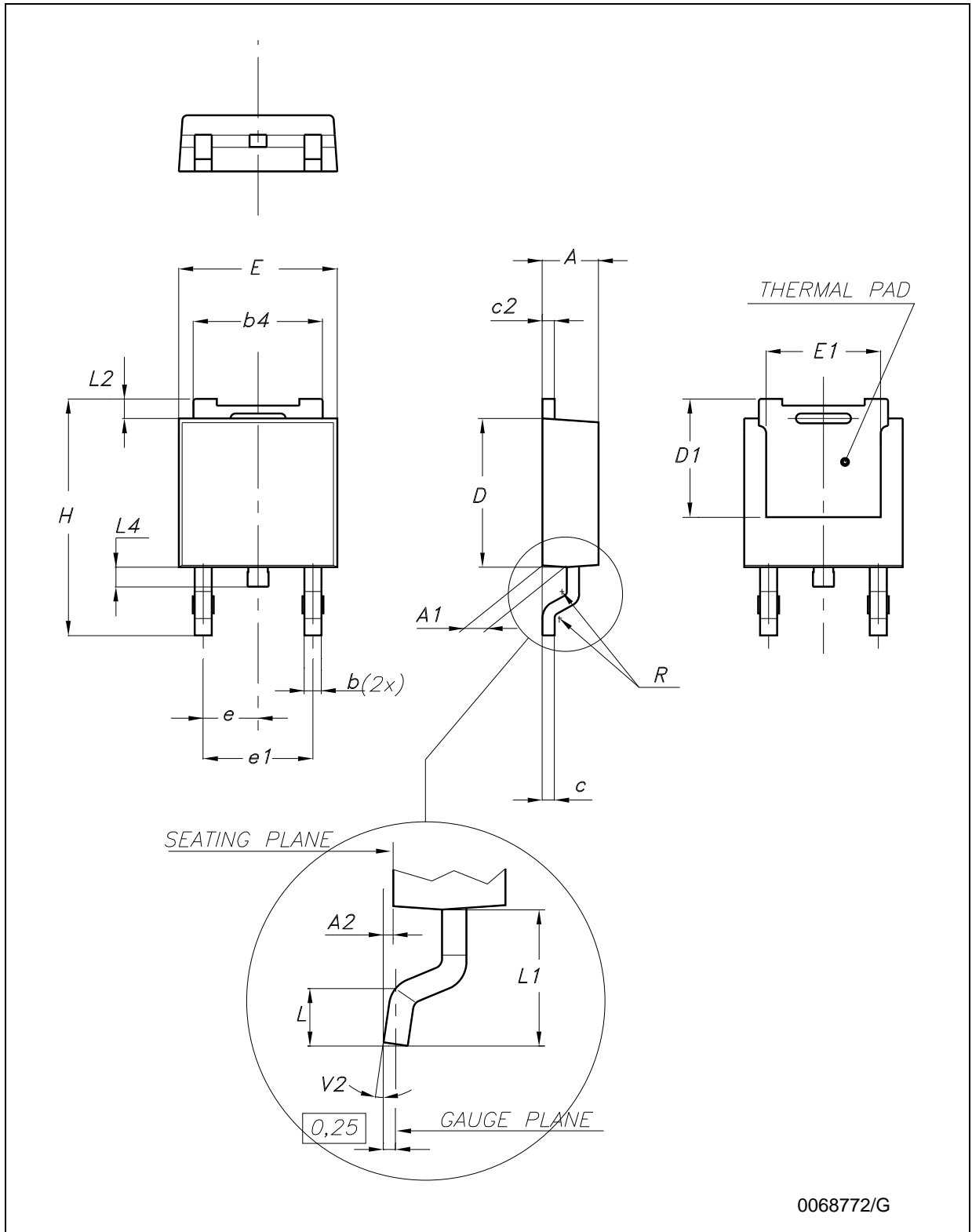

0068772/G

Table 12. DPAK mechanical data

Dim.	Type STD-ST			Type FUJITSU-Subcon.			Type IDS-Subcon		
	mm.			mm.			mm.		
	Min.	Typ.	Max.	Min.	Typ.	Max.	Min.	Typ.	Max.
A	2.20		2.40	2.25	2.30	2.35	2.19		2.38
A1	0.90		1.10	0.96		1.06	0.89		1.14
A2	0.03		0.23	0		0.10	0.03		0.23
b	0.64		0.90	0.76		0.86	0.64		0.88
b4	5.20		5.40	5.28		5.38	5.21		5.46
c	0.45		0.60	0.46		0.56	0.46		0.58
c2	0.48		0.60	0.46		0.56	0.46		0.58
D	6.00		6.20	6.05		6.15	5.97		6.22
D1		5.10		5.27		5.47		5.20	
E	6.40		6.60	6.55	6.60	6.65	6.35		6.73
E1		4.70			4.77			4.70	
e		2.28		2.23	2.28	2.33		2.28	
e1	4.40		4.60				4.51		4.61
H	9.35		10.10	9.90		10.30	9.40		10.42
L	1.00			1.40		1.60	0.90		
L1		2.80					2.50		2.65
L2		0.80		1.03		1.13	0.89		1.27
L4	0.60		1.00	0.70		0.90	0.64		1.02
R		0.20			0.40			0.20	
V2	0°		8°	0°		8°	0°		8°

Note: *The DPAK package coming from the two subcontractors (Fujitsu and IDS) are fully compatible with the ST's package suggested footprint.*



Figure 36. DPAK footprint recommended data

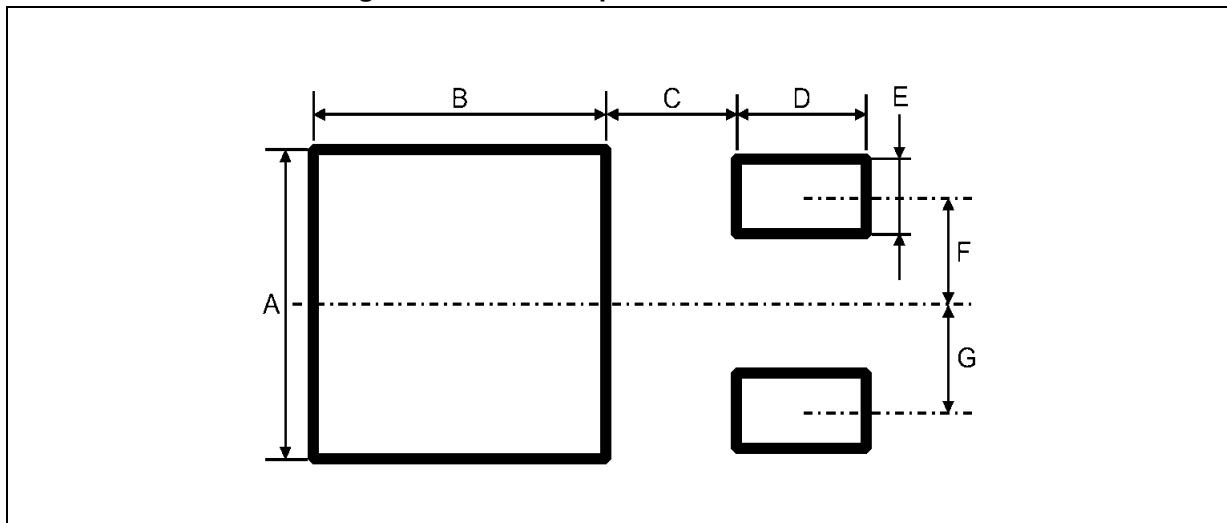
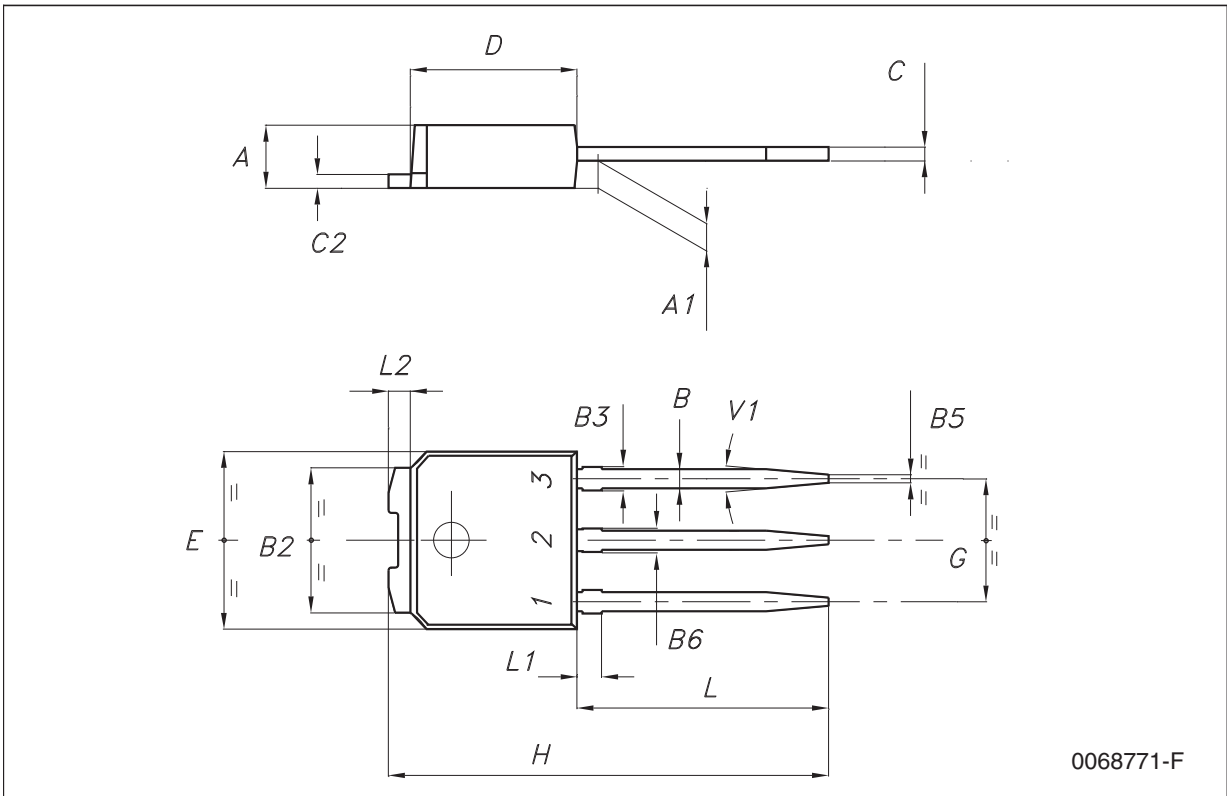

Table 13. Footprint data

Dim.	Values	
	mm.	inch.
A	6.70	0.264
B	6.70	0.64
C	1.8	0.070
D	3.0	0.118
E	1.60	0.063
F	2.30	0.091
G	2.30	0.091

**IPAK mechanical data**

Dim.	mm.			inch.		
	Min.	Typ.	Max.	Min.	Typ.	Max.
A	2.2		2.4	0.086		0.094
A1	0.9		1.1	0.035		0.043
B	0.64		0.9	0.025		0.035
B2	5.2		5.4	0.204		0.212
B3			0.95			0.037
B5		0.3			0.012	
B6			0.95			0.037
C	0.45		0.6	0.017		0.023
C2	0.48		0.6	0.019		0.023
D	6		6.2	0.236		0.244
E	6.4		6.6	0.252		0.260
G	4.4		4.6	0.173		0.181
H	15.9		16.3	0.626		0.641
L	9		9.4	0.354		0.370
L1	0.8		1.2	0.031		0.047
L2		0.8	1		0.031	0.039



**Tape & reel DPAK-PPAK mechanical data**

Dim.	mm.			inch.		
	Min.	Typ.	Max.	Min.	Typ.	Max.
A			330			12.992
C	12.8	13.0	13.2	0.504	0.512	0.519
D	20.2			0.795		
N	60			2.362		
T			22.4			0.882
Ao	6.80	6.90	7.00	0.268	0.272	0.276
Bo	10.40	10.50	10.60	0.409	0.413	0.417
Ko	2.55	2.65	2.75	0.100	0.104	0.105
Po	3.9	4.0	4.1	0.153	0.157	0.161
P	7.9	8.0	8.1	0.311	0.315	0.319

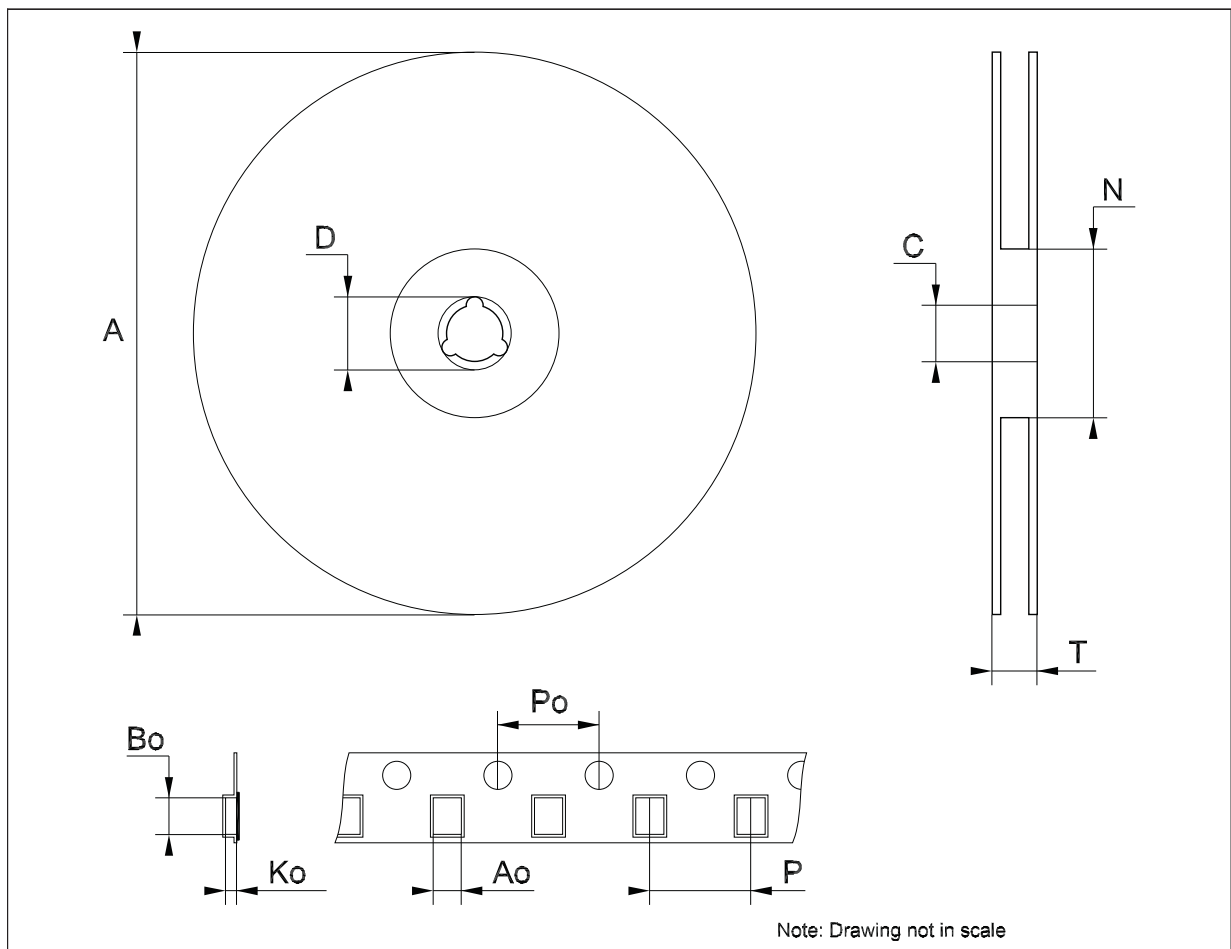

## 8 Revision history

**Table 14. Document revision history**

Date	Revision	Changes
21-Jun-2004	6	Document updating.
30-Aug-2006	7	Order codes updated.
29-Nov-2006	8	DPAK mechanical data updated and add footprint data.
06-Jun-2007	9	Order codes updated.
10-Dec-2007	10	Added <a href="#">Table 1</a> .
19-Feb-2008	11	Modified: <a href="#">Table 1 on page 1</a> .
15-Jul-2008	12	Modified: <a href="#">Table 1 on page 1</a> and <a href="#">Table 14 on page 29</a> .
07-Apr-2009	13	Modified: <a href="#">Figure 9 on page 11</a> and <a href="#">Figure 15 on page 12</a> .
14-Jun-2010	14	Added: <a href="#">Table 11 on page 17</a> , <a href="#">Figure 29 on page 18</a> , <a href="#">Figure 30 on page 19</a> , <a href="#">Figure 31</a> and <a href="#">Figure 32 on page 20</a> .
11-Nov-2010	15	Modified: $R_{thJC}$ value for TO-220 <a href="#">Table 3 on page 5</a> .
08-Feb-2012	16	Added: order codes L78M05CV-DG, L78M12CV-DG and L78M15CV-DG <a href="#">Table 1 on page 1</a> .
09-Mar-2012	17	Added: order codes L78M08CV-DG and L78M09CV-DG <a href="#">Table 1 on page 1</a> .
15-May-2012	18	Added: order codes L78M24CV-DG <a href="#">Table 1 on page 1</a> .
19-Apr-2013	19	Removed: Available on request footnote 2 <a href="#">Table 1 on page 1</a> .