

DESCRIPTION

MPS1410 is high efficiency step down DC/DC converter operated with current mode and constant frequency. MPS1410 can supply 2A of load current from 4.75V to 15V input voltage. The output voltage can be regulated from 1.23 to 13V. The switching frequency is set at 380kHz, allowing the use of a minimum number of surface mount inductors and capacitors. MPS1410 is available in a green SOP package.

FEATURES

- 2A output current
- High efficiency up to 95%
- 25uA shutdown current
- 4.75V to 15V supply voltage
- 380kHz constant frequency
- Output adjustable from 1.23 to 13V
- Over temperature protection
- Over current protection
- Under voltage lockout
- SOP-8L Package
- RoHS Compliant and 100 % Lead (Pb) Free

APPLICATIONS

- PC motherboard
- Set-top box
- LCD display
- Battery charger

ORDERING INFORMATION

PART	PACKAGE	RoHS	Ship, Quantity
MPS1410S	SOP-8L	Yes	Tape and Reel, 2500

Pin Configuration

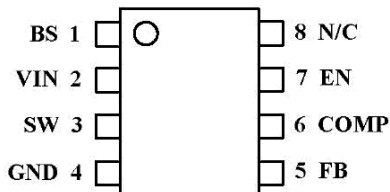

Absolute Maximum Rating

VIN to GND.....-0.3V to +16V
 SW Voltage to GND.....-0.3V to VIN+0.3V
 BS Voltage to GND.....V_{SW}-0.3V to V_{SW} +6V
 All Other Pins.....-0.3V to +6V
 Operating Temperature Range.....-20 to +85
 Maximum Junction Temperature.....+150
 Storage Temperature Range.....-65 to 150
 Lead Temperature (Soldering 10s).....+260

CAUTION: Stresses above those listed in “Absolute Maximum Ratings may cause permanent damage to the device. This is a stress only rating and operation of the device at these or any other conditions above those indicated in the operational sections of this specification is not implied.

Electro-Static Discharge Sensitivity

This integrated circuit can be damaged by ESD. It is recommended that all integrated circuits be handled with proper precautions. Failure to observe proper handling and installation procedures can cause damage. ESD damage can range from subtle performance degradation to complete device failure.

Package Thermal Characteristics

Thermal Resistance, Θ_{JA}110 /W

Pin Description

Pin	Symbol	Description
1	BS	Boost input for high-side MOSFET switch
2	VIN	Supply voltage
3	SW	Power switch output
4	GND	Ground pin
5	FB	Feedback voltage pin
6	COMP	Compensation pin
7	EN	Chip enable input; For automatic enable, leave EN unconnected.
8	NC	No connect

Block Diagram

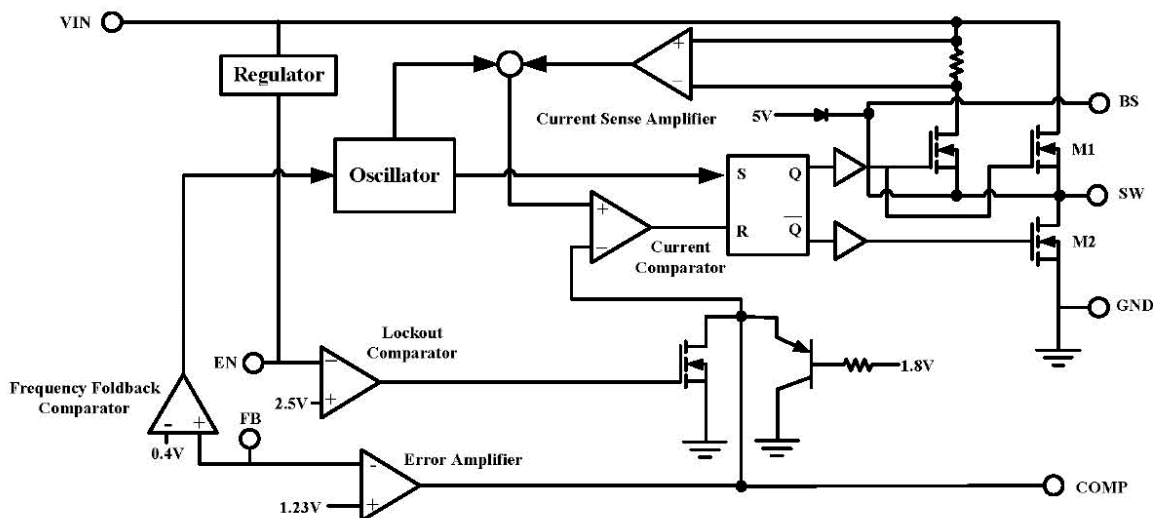

Typical Application Circuit

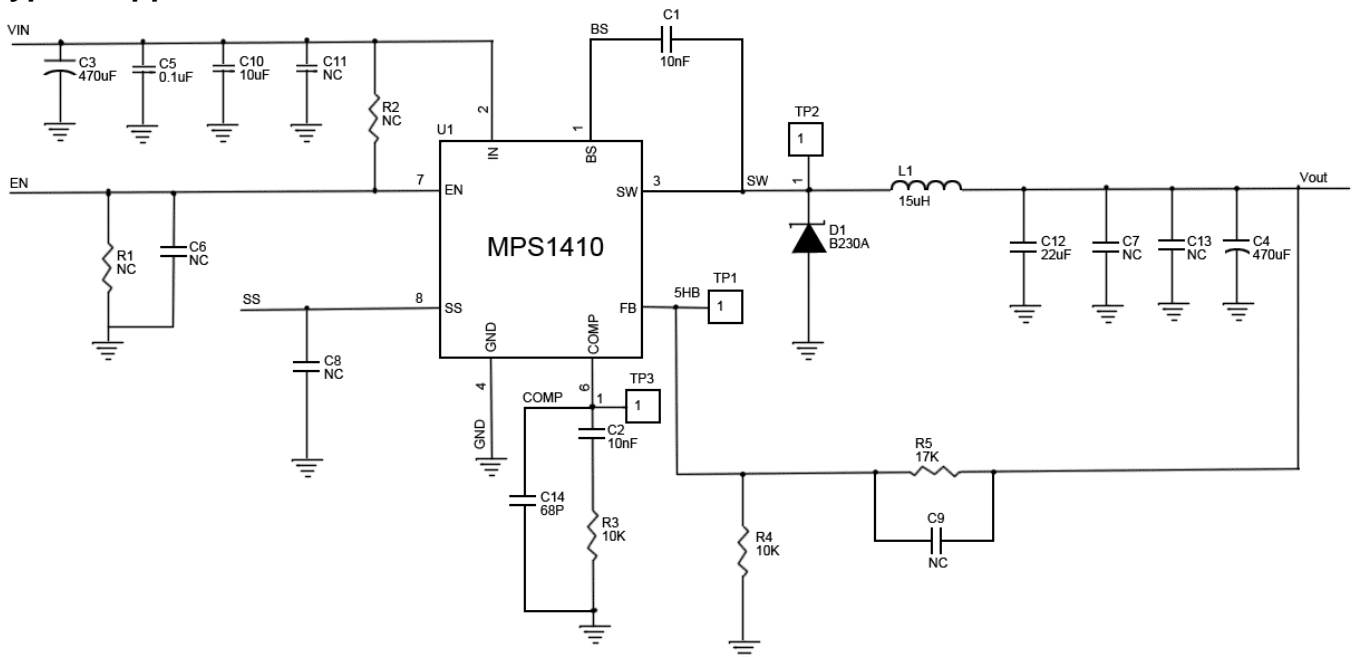

V_{IN}=5V

	C1	C2	C10	C5	C4	C9	C14	C13	C6
1.2V	10nF	1nF	NC	10u	100uF	NC	1nF	22uF	1uF
	R5	R4	R3	L1	D1	U1	other Capacitor	other resistor	R2
1.8V	1K	NC	47K	6.8U	B320A	MPS1410A	NC	NC	10K

Vout	C1	C2	C3	C5	C4	C9	C14	C13	C6
5V	10nF	22nF	220uF	10uF/50V	100uF	0.1uF	3.3nF	1uF	1uF
3.3V	10nF	22nF	220uF	10uF/50V	100uF	0.1uF	3.3nF	1uF	1uF
2.5V	10nF	10nF	220uF	10u/50V*2	100uF	0.1uF	3.3nF	1uF	1uF
1.8V	10nF	10nF	220uF	10u/50V*2	100uF	0.1uF	3.3nF	1uF	1uF
	R5	R4	R3	L1	D1	U1	other Capacitor	other resistor	R2
5V	68K	22K	6.8K	15u	B320A	MPS1410A	NC	NC	10K
3.3V	17K	10K	6.8K	15u	B320A	MPS1410A	NC	NC	10K
2.5V	10.47K	10K	6.8K	6.8u	B320A	MPS1410A	NC	NC	10K
1.8V	4.7K	10K	5.6K	6.8u	B320A	MPS1410A	NC	NC	10K

*NOTE:

5V for $8V \leq V_{IN} \leq 22V$

3.3V for $6V \leq V_{IN} \leq 23V$

2.5V for $5V \leq V_{IN} \leq 20V$

1.8V for $5V \leq V_{IN} \leq 18V$

Electrical Specifications

($V_{IN} = +12V$, typical values are at $T_A = +25^\circ C$, unless otherwise noted.)

Parameter	Symbol	Test Conditions	Min	Typ	Max	Unit
Supply Voltage	V_{IN}		4.75		15	V
Feedback voltage	V_{FB}	$4.75V < V_{IN} < 15V$	1.184	1.23	1.258	V
High-Side Switch On Resistance*	R_{HS}			0.22		Ω
Low-Side Switch On Resistance*	R_{LS}			10		Ω
High-Side Switch Leadage	I_{HS}	$V_{EN} = V_{SW} = 0V$			10	μA
Inductance Current Limit*	I_{OL}		2.4	2.95		A
Switching Frequency	f_{SW}		320	380	440	kHz
Short Circuit Frequency	f_{SC}			120		kHz
Max. Duty Cycle		$V_{FB} = 1V$		90		%
Min. Duty Cycle		$V_{FB} = 1.5V$			0	%
Current Sense to COMP Transconductance	G_{CS}			1.75		A/V
V_{IN} Under Voltage Lockout Threshold	V_{UI}	V_{IN} Rising	3.4	4.0	4.4	V
Undeer Voltage Lockout Threshold (Hysteresis)	V_{UH}			200		mV
EN Threshold Voltage	V_{ET}			2.5		V
Shutdown Current	I_{SD}	$V_{EN} = 0V$		25	50	μA
Operation Current	I_{OP}	$V_{EN} = 0, V_{FP} = 1.4V$		1	1.5	mA
Thermal Shutdown*	T_{SD}			160		

*Guaranteed by design not for test

TYPICAL CHARACTERISTICS

($V_{IN}=12V$, $V_{OUT}=3.3V$, $T_A=25^\circ C$, unless otherwise noted)

Efficiency vs. Output Current and Voltage

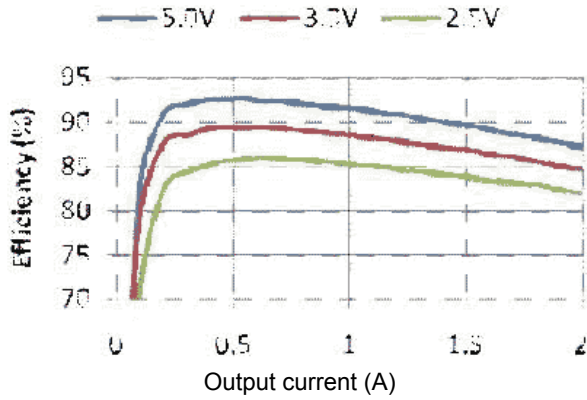

Medium Loading Operation ($I_L=1A$)

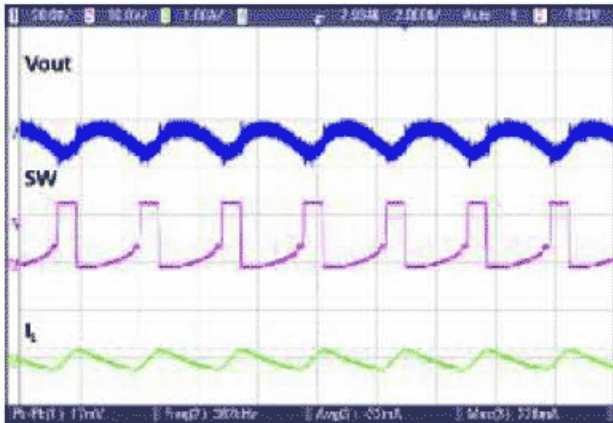

Dynamic Loading Operation ($I_L=1\sim 2A$)

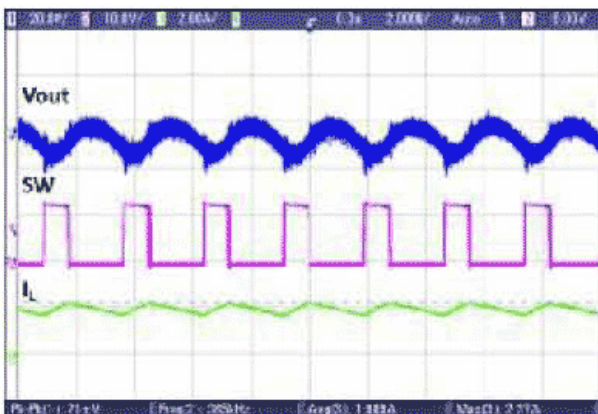

Soft Start & Inrush Current

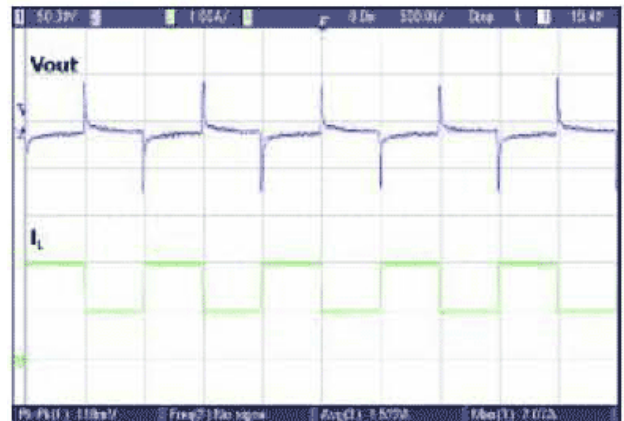
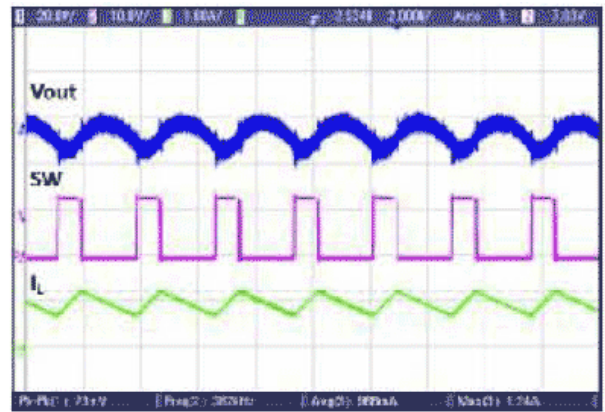
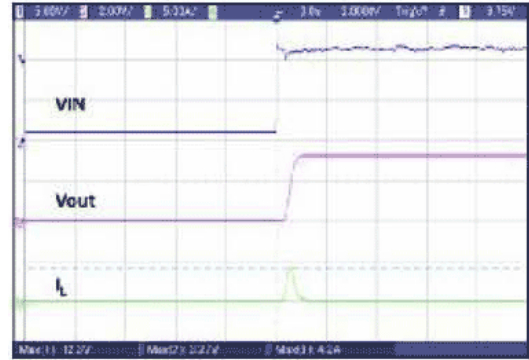

FUNCTIONAL DESCRIPTION

Overviews

The MPS1410 is a current-mode step-down switch-mode regulator. It regulates input voltages from 4.75V to 15V down to an output voltage as low as 1.23V, and is able to supply up to 2A of load current. The MPS1410 uses current-mode control to regulate the output voltage. The output voltage is measured at FB through a resistive voltage divider and amplified through the internal error amplifier. The output current of the transconductance error amplifier is presented at COMP where a network compensates the regulation control system. The voltage at COMP is compared to the switch current measured internally to control the output voltage.

The converter uses an internal n-channel MOSFET switch to step down the input voltage to the regulated output voltage. Since the MOSFET requires a gate voltage greater than the input voltage, a boost capacitor connected between SW and BS drives the gate. The capacitor is internally charged while the switch is off. An internal 10 Ω switch from SW to GND is used to insure that SW is pulled to GND when the switch is off to fully charge the BS capacitor.

Application Information

The output voltage is set using a resistive voltage divider from the output voltage to feedback voltage pin. The voltage divider divides the output voltage down by the ratio:

$$V_{FB} = V_{OUT} * R4 / (R4 + R5)$$

Thus the output voltage is:

$$V_{OUT} = V_{FB} * (R4 + R5) / R4$$

The typical value of R4 and feedback voltage is 10kΩ and 1.23V, respectively. If the output voltage is 3.3V, using the above equation, R5 is about 17kΩ.

Selection of Inductor

The inductor is required to supply constant current to the output load while being driven by the switched input voltage. A larger value inductor has a larger physical size, higher series resistance, and/or lower saturation current. Choose an inductor that does not saturate under the worst-case load conditions. A good rule for determining the inductance is to allow the peak-to-peak ripple current in the inductor to be approximately 30% of the maximum load current. Also, make sure that the peak inductor current (the load current plus half the peak-to-peak inductor ripple current) is below the 2.4A minimum current limit. The inductance value can be calculated by the equation:

$$L = V_{OUT} * (V_{IN} - V_{OUT}) / (V_{IN} * f_{SC} * \Delta I)$$

Where V_{OUT} is the output voltage, V_{IN} is the supply voltage, f_{SC} is the switching frequency and ΔI is the peak-to-peak inductor ripple current.

Input Capacitor

The input current to the step-down converter is discontinuous, and therefore an input capacitor C10 is required to supply the AC current to the step-down converter while maintaining the DC input voltage. A low ESR capacitor is required to keep the noise at the IC to a minimum. Ceramic capacitors are

preferred, but tantalum or low-ESR electrolytic capacitors may also suffice.

The input capacitor value should be greater than 10μF. The capacitor can be electrolytic, tantalum or ceramic. However since it absorbs the input switching current it requires an adequate ripple current rating. Its RMS current rating should be greater than approximately 1/2 of the DC load current.

For insuring stable operation C5 should be placed as close to the IC as possible. Alternately a smaller high quality ceramic 0.1μF capacitor may be placed closer to the IC and a larger capacitor placed further away. If using this technique, it is recommended that the larger capacitor be a tantalum or electrolytic type. All ceramic capacitors should be placed close to the MPS1410.

Output Capacitor

The output capacitor is required to maintain the DC output voltage. Low ESR capacitors are preferred to keep the output voltage ripple low. The characteristics of the output voltage ripple low. The characteristics of the output capacitor also affect the stability of the regulation control system. Ceramic, tantalum, or low ESR electrolytic capacitors are recommended. In the case of ceramic capacitors, the impedance at the switching frequency is dominated by the capacitance, and so the output voltage ripple is mostly independent of the ESR.

The output voltage ripple is estimated to be:

$$V_{RIPPLE} = 1.4 * V_{IN} * (f_{LC} / f_{SW})^2$$

Where V_{RIPPLE} is the output ripple voltage, V_{IN} is the input voltage, f_{LC} is the resonant frequency of the LC filter, f_{SW} is the switching frequency. In the case of tantalum or low ESR electrolytic capacitors, the ESR dominates the impedance at the switching frequency, and so the output ripple is calculated as:

$$V_{RIPPLE} = \Delta I * R_{ESR}$$

Where V_{RIPPLE} is the output voltage ripple, ΔI is the inductor ripple current, and R_{ESR} is the equivalent series resistance of the output capacitors.

Output Rectifier Diode

The output rectifier diode supplies the current to the inductor when the high-side switch is off. To reduce losses due to the diode forward voltage and recovery times, use a Schottky rectifier. Choose a rectifier which maximum reverse voltage is greater than the maximum input voltage and which current rating is greater than maximum load current.

Compensation

The system stability is controlled through the COMP pin. COMP is the output of the internal transconductance error amplifier. A series capacitor-resistor combination sets a pole-zero combination to control the characteristics of the control system. Choose the compensation resistor (R3) to set the desired crossover frequency. Choose the compensation capacitor (C2) to set the zero to 1/4 of the crossover frequency. In certain case of instability, add the second compensation capacitor (C14) is necessary.

Package Dimensions (SOP-8L)

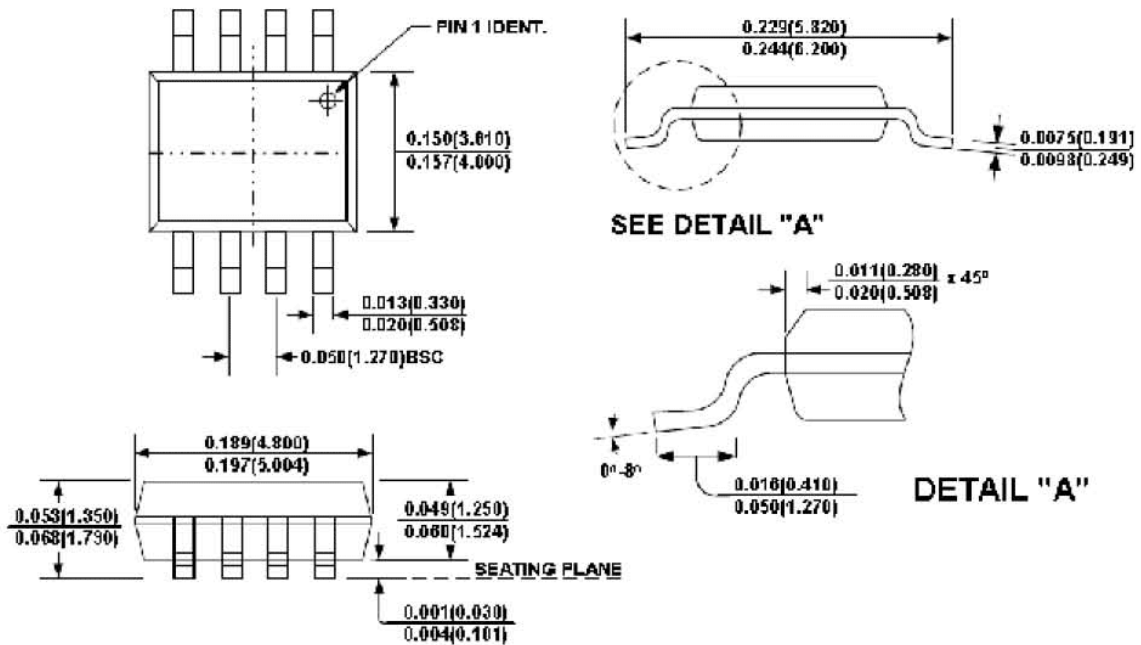

Note: The standard dimension is inches and the dimension in bracket is millimeters.