

# 负温度系数热敏电阻器：SCK 系列



## 突波电流抑制用功率型热敏电阻器

### ■ 特点

1. 满足RoHS和无卤的要求
2. 本体尺寸：Φ5mm~ Φ30mm
3. 径向引线树脂封装
4. 高额定功率
5. 宽阻值范围
6. 低成本
7. 工作温度范围
  - Φ5mm：-40℃~+150℃
  - Φ8~Φ10mm：-40℃~+170℃
  - Φ13mm~Φ30mm：-40℃~+200℃
8. 安规认证：UL / cUL / TUV / CQC

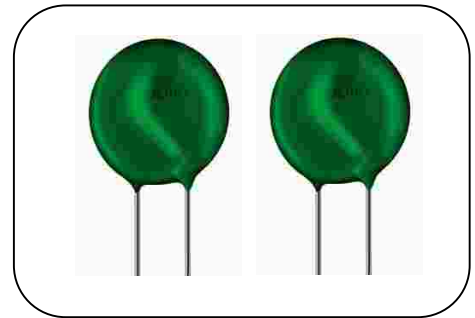

### ■ 用途

1. 开关型电源供应器
2. 电子马达
3. 变压器
4. 适配器
5. 放映机
6. 卤素灯
7. LED 驱动电路

### ■ 编码规则

#### ● Φ5mm~ Φ15mm

1	2	3	4	5	6	7	8	9	10	11	12	13	14	15	16
产品类型		本体尺寸			零功率电阻 25°C (R <sub>25</sub> )		最大稳态电流 @25°C		R <sub>25</sub> 公差		外观		可选后缀		
SCK	兴勤 NTC 热敏电阻 SCK系列	05	Φ5mm	08	Φ8mm	0R5	0.5Ω	X3	0.3A	L	±15%	S	直脚	Y	满足RoHS & 无卤要求
		10	Φ10mm	13	Φ13mm	2R5	2.5Ω	2X	2.5A	M	±20%	F	Y 型引脚		
		15	Φ15mm			08	8Ω	8	8A	N	±25%	T	L 型引脚		
						20	20Ω	10	10A						
						120	120Ω								

#### ● Φ20mm~ Φ30mm

1	2	3	4	5	6	7	8	9	10	11	12	13	14	15
产品类型		本体尺寸		零功率电阻 25°C (R <sub>25</sub> )		R <sub>25</sub> 公差		外观		包装		可选后缀		
SCK	兴勤 NTC 热敏电阻 SCK系列	20	Φ20mm	R <sub>25</sub> < 10Ω	L	±15%	S	直脚	B	散装	Y	满足 RoHS & 无卤要求 (适用于 SCK05~SCK20 系列)		
		25	Φ25mm	0R7:0.7Ω	M	±20%	F	Y 型引脚			H	满足RoHS & 无卤要求 (只适用于 SCK25 和 SCK30 系列)		
		30	Φ30mm	2R5:2.5Ω	N	±25%	T	L 型引脚						
				R <sub>25</sub> ≥ 10Ω										
				100:10Ω										
				470:47Ω										
				471:470Ω										

# 负温度系数热敏电阻器：SCK 系列



## 突波电流抑制用功率型热敏电阻器

### ■ 结构与尺寸

#### S 型 (直脚)

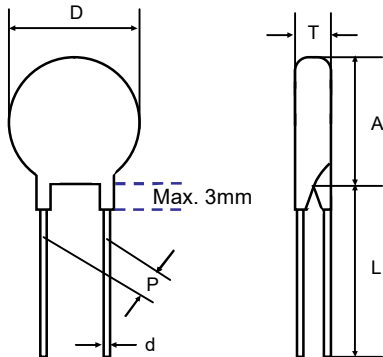

(单位：mm)

系列	Dmax.	P.	d	Amax.	Lmin.	Tmax.	W
SCK05	4.5~6.5	4±0.5	0.8±0.02	6.5	31	2.0~5.0	1.9±0.2
SCK08	6.0~9.5	5±0.5	0.8±0.02	9.5	31	2.5~5.0	2.1±0.3
SCK10	9.0~11.5	5±0.5	0.8±0.02	11.5	31	2.5~5.0	2.1±0.3
SCK13	11.5~14.5	7.5±0.5	0.8±0.02	14.5	30	2.5~6.0	2.3±0.3
SCK15	13.0~16.5	7.5±0.5	1.0±0.02	16.5	29	3.0~6.0	2.5±0.3
SCK20	18.0~21.5	7.5±0.5	1.0±0.02	21.5	26	3.5~6.0	2.6±0.3
SCK25	23.0~29.0	7.5±1	1.0±0.02	29.0	25	4.0~6.0	3.1±0.5
SCK30	30.0~36.0	7.5±1	1.0±0.02	36.0	23	4.0~6.0	3.1±0.5

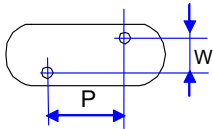

#### F 型 (Y型引脚)

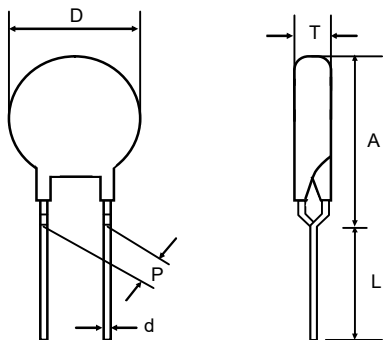

(单位：mm)

系列	Dmax.	P	d	Amax.	Lmin.	Tmax.
SCK05	4.5~6.5	4±0.5	0.8±0.02	11.0	29	2.0~5.0
SCK08	6.0~9.5	5±0.5	0.8±0.02	13.0	29	2.5~5.0
SCK10	9.0~11.5	5±0.5	0.8±0.02	15.0	29	2.5~5.0
SCK13	11.5~14.5	7.5±0.5	0.8±0.02	17.5	27	2.5~6.0
SCK15	13.0~16.5	7.5±0.5	1±0.02	19.0	26	3.0~6.0
SCK20	18.0~21.5	7.5±0.5	1±0.02	24.5	25	3.5~6.0
SCK25	23.0~29.0	7.5±1	1±0.02	35.0	22	4.0~6.0
SCK30	30.0~36.0	7.5±1	1±0.02	42.0	22	4.0~6.0

#### T 型 (L型引脚)

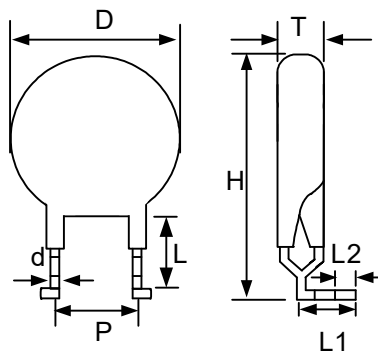

(单位：mm)

系列	Dmax.	P	d	Tmax.	L	Hmax.	L1	L2
SCK08	6.0~9.5	5±0.5	0.8±0.02	2.5~5.0	5.0±0.5	15	7.8±1.0	3.5±0.5
SCK10	9.0~11.5	5±0.5	0.8±0.02	2.5~5.0	5.0±0.5	17	7.8±1.0	3.5±0.5
SCK13	11.5~14.	7.5±0.5	0.8±0.02	2.5~6.0	5.0±0.5	19	7.8±1.0	3.5±0.5
SCK15	13.0~16.	7.5±0.5	1.0±0.02	3.0~6.0	4.5±0.5	21	9.0±1.0	3.5±0.5
SCK20	18.0~21.	7.5±0.5	1.0±0.02	3.5~6.0	4.5±0.5	26	9.0±1.0	3.5±0.5

# 负温度系数热敏电阻器：SCK 系列



## 突波电流抑制用功率型热敏电阻器

### ■ 电气特性

型号	零功率电阻 @25°C	最大 稳态电流 @25°C	最大稳态 电流下的 残余电阻 @25°C	建议电容值 @240Vac	最大 额定功率 @25°C	耗散系数	热时常数	工作 温度范围
	R <sub>25</sub> (Ω)	I <sub>max</sub> (A)	R <sub>Imax</sub> (Ω)	C <sub>th</sub> (μF)	P <sub>max</sub> (W)	δ(mW/°C)	τ (Sec.)	T <sub>L</sub> ~T <sub>U</sub> (°C)
SCK05052□	5	2	0.429	100	1.8	約 15	約 17	-40 ~ +150
SCK05081□	8	1	1.089	68				
SCK05101□	10	1	1.126	100				
SCK05121□	12	1	1.184	68				
SCK0520X3□	20	0.3	5.560	100				
SCK08042□	4	2	0.441	220	2.3	約 16	約 38	-40 ~ +170
SCK084R72□	4.7	2	0.445	220				
SCK08053□	5	3	0.261	220				
SCK08063□	6	3	0.283	220				
SCK08073□	7	3	0.287	220				
SCK08082□	8	2	0.520	220				
SCK08102□	10	2	0.542	220				
SCK08152□	15	2	0.548	100				
SCK08201□	20	1	1.544	100				
SCK0830X□	30	0.5	4.094	100				
SCK10015□	1	5	0.091	470				
SCK101R35□	1.3	5	0.095	330				
SCK101R55□	1.5	5	0.101	330				
SCK102R55A□	2.5	5	0.120	470				
SCK10035□	3	5	0.127	560				
SCK10044□	4	4	0.161	560				
SCK10054□	5	4	0.180	470				
SCK106R83□	6.8	3	0.270	330				
SCK10083□	8	3	0.278	330				
SCK10103□	10	3	0.297	330				
SCK10123□	12	3	0.301	470				
SCK10133□	13	3	0.356	330				
SCK10152X□	15	2.5	0.442	330				
SCK10162X□	16	2.5	0.471	330				
SCK10202□	20	2	0.646	330				
SCK10222□	22	2	0.659	220				
SCK10252□	25	2	0.674	330				
SCK10302□	30	2	0.700	330				
SCK10472□	47	2	0.720	330				
SCK10502□	50	2	0.813	330				
SCK10801□	80	1	2.236	220				
SCK101001□	100	1	2.318	200				
SCK101201□	120	1	2.406	200				
					2.4	約 17	約 43	-40 ~ +170

备注 1：□ = R<sub>25</sub> 公差

备注 2：如有特殊要求请与我们的销售人员联系

# 负温度系数热敏电阻器：SCK 系列



## 突波电流抑制用功率型热敏电阻器

### ■ 电气特性

型号	零功率电阻 @25°C	最大 稳态电流 @25°C	最大稳态 电流下的 残余电阻 @25°C	建议电容值 @240Vac	最大 额定功率 @25°C	耗散系数	热时常数	工作 温度范围
	R <sub>25</sub> (Ω)	I <sub>max</sub> (A)	R <sub>Imax</sub> (Ω)	C <sub>th</sub> (μF)	P <sub>max</sub> (W)	δ(mW/°C)	τ (Sec.)	T <sub>L</sub> ~T <sub>U</sub> (°C)
SCK13013□	1	3	0.174	560	3.1	約 18	約 66	-40 ~ +200
SCK131R37□	1.3	7	0.070	470				
SCK132R56□	2.5	6	0.094	560				
SCK13045□	4	5	0.132	560				
SCK134R74□	4.7	4	0.168	560				
SCK13055□	5	5	0.166	560				
SCK13074□	7	4	0.184	470				
SCK13084□	8	4	0.206	470				
SCK13104□	10	4	0.217	470				
SCK13124□	12	4	0.230	560				
SCK13153□	15	3	0.343	560				
SCK13163□	16	3	0.348	560				
SCK13183□	18	3	0.365	560				
SCK13203□	20	3	0.410	470				
SCK150R78A□	0.7	8	0.051	680	3.6	約 21	約 75	-40 ~ +200
SCK15018□	1	8	0.054	680				
SCK151R38□	1.3	8	0.064	680				
SCK151R58□	1.5	8	0.068	800				
SCK15028□	2	8	0.078	680				
SCK152R58□	2.5	8	0.086	680				
SCK15037□	3	7	0.091	820				
SCK15046□	4	6	0.117	800				
SCK15056□	5	6	0.121	820				
SCK15065□	6	5	0.159	680				
SCK15075□	7	5	0.161	820				
SCK15085□	8	5	0.165	680				
SCK15105□	10	5	0.178	820				
SCK15125□	12	5	0.185	680				
SCK15154□	15	4	0.261	820				
SCK15164□	16	4	0.265	820				
SCK15184□	18	4	0.273	680				
SCK15204□	20	4	0.283	820				
SCK15224□	22	4	0.308	560				
SCK15253□	25	3	0.425	680				
SCK15303□	30	3	0.461	680				
SCK15333□	33	3	0.484	560				
SCK15403□	40	3	0.511	680				
SCK15473□	47	3	0.517	680				
SCK15802X□	80	2.5	0.693	560				
SCK151202□	120	2	1.010	560				

备注 1：□ = R<sub>25</sub> 公差

备注 2：如有特殊要求请与我们的销售人员联系

# 负温度系数热敏电阻器：SCK 系列



## 突波电流抑制用功率型热敏电阻器

### ■ 电气特性

型号	零功率电阻 @25°C	最大 稳态电流 @25°C	最大稳态 电流下的 残余电阻 @25°C	建议电容值 @240Vac	最大 额定功率 @25°C	耗散系数	热时常数	工作 温度范围
	R <sub>25</sub> (Ω)	I <sub>max</sub> (A)	R <sub>Imax</sub> (Ω)	C <sub>th</sub> (μF)	P <sub>max</sub> (W)	δ(mW/°C)	τ (Sec.)	T <sub>L</sub> ~T <sub>U</sub> (°C)
SCK200R7□	0.7	15	0.035	1000	4.9	約 28	約 113	-40 ~ +200
SCK201R0□	1	13	0.034					
SCK201R5□	1.5	10.5	0.041					
SCK202R0□	2	10	0.062					
SCK202R5□	2.5	9	0.083					
SCK203R0□	3	8.5	0.078					
SCK204R0□	4	8	0.080					
SCK204R7□	4.7	7.5	0.114					
SCK205R0□	5	7.5	0.118					
SCK206R0□	6	7	0.120					
SCK206R8□	6.8	6.5	0.130					
SCK207R0□	7	6.5	0.132					
SCK208R0□	8	6	0.161					
SCK20100□	10	5.5	0.196					
SCK20120□	12	5	0.197					
SCK20130□	13	5	0.213					
SCK20150□	15	4.5	0.258					
SCK20160□	16	4.5	0.276					
SCK20180□	18	4	0.280					
SCK20200□	20	4	0.306					
SCK251R0□	1	20	0.020	1200	7.0	約 30	約 130	-40 ~ +200
SCK251R5□	1.5	18.5	0.023					
SCK252R0□	2	18	0.025					
SCK252R5□	2.5	15	0.032					
SCK253R0□	3	14.5	0.042					
SCK254R0□	4	14	0.044					
SCK254R7□	4.7	13	0.052					
SCK255R0□	5	12	0.061					
SCK256R8□	6.8	10.5	0.082					
SCK257R0□	7	10	0.092					
SCK258R0□	8	9	0.115					
SCK25100□	10	8	0.141					
SCK25120□	12	7.5	0.164					
SCK25150□	15	6.5	0.210					
SCK25180□	18	5.5	0.231					
SCK25200□	20	5	0.270					

备注 1：□ = R<sub>25</sub> 公差

备注 2：如有特殊要求请与我们的销售人员联系

# 负温度系数热敏电阻器：SCK 系列



## 突波电流抑制用功率型热敏电阻器

### ■ 电气特性

型号	零功率电阻 @25°C	最大 稳态电流 @25°C	最大稳态 电流下的 残余电阻 @25°C	建议电容值 @240Vac	最大 额定功率 @25°C	耗散系数	热时常数	工作 温度范围
	R <sub>25</sub> (Ω)	I <sub>max</sub> (A)	R <sub>Imax</sub> (Ω)	C <sub>th</sub> (μF)	P <sub>max</sub> (W)	δ(mW/°C)	τ (Sec.)	T <sub>L</sub> ~T <sub>U</sub> (°C)
SCK301R0□	1	30	0.016	1500	8.0	約 40	約 190	-40 ~ +200
SCK301R5□	1.5	25	0.020					
SCK302R0□	2	23	0.022					
SCK302R5□	2.5	18	0.030					
SCK303R0□	3	17	0.035					
SCK304R0□	4	16	0.048					
SCK304R7□	4.7	15	0.055					
SCK305R0□	5	14	0.057					
SCK306R8□	6.8	12	0.077					
SCK307R0□	7	11.5	0.084					
SCK308R0□	8	10.5	0.100					
SCK30100□	10	10	0.115					
SCK30120□	12	9	0.142					
SCK30150□	15	8	0.175					
SCK30180□	18	7	0.210					
SCK30200□	20	6	0.233					

备注 1：□ = R<sub>25</sub> 公差

备注 2：如有特殊要求请与我们的销售人员联系

# 负温度系数热敏电阻器：SCK 系列



## 突波电流抑制用功率型热敏电阻器

### ■ 安规认证

- UL&cUL 证书号：E138827
- CSA 证书号：97495
- TUV 证书号：R 50050155
- CQC 证书号：CQC05001011984,993,985,942,943,944 , CQC05001011988,989,990,963,964,965

本体尺寸	认证型号	安规认证				
		UL	cUL	CSA	TUV	CQC
5mm	SCK-052	√	√	√	√	√
	SCK-081	√	√		√	√
	SCK-101	√	√	√	√	√
	SCK-121	√	√		√	√
	SCK-20X3	√	√	√	√	√
8mm	SCK-042	√	√	√	√	√
	SCK-4R72	√	√	√	√	√
	SCK-053	√	√	√	√	√
	SCK-063	√	√	√	√	√
	SCK-073	√	√		√	√
	SCK-082	√	√	√	√	√
	SCK-102	√	√	√	√	√
	SCK-152	√	√	√	√	√
	SCK-201	√	√	√	√	√
	SCK-30X	√	√	√	√	√
10mm	SCK-015	√	√		√	√
	SCK-1R35	√	√		√	√
	SCK-1R55	√	√		√	√
	SCK-2R55A	√	√	√	√	√
	SCK-035	√	√	√	√	√
	SCK-044	√	√	√	√	√
	SCK-054	√	√	√	√	√
	SCK-6R83	√	√	√	√	√
	SCK-083	√	√	√	√	√
	SCK-103	√	√	√	√	√
	SCK-123	√	√	√	√	√
	SCK-133	√	√	√	√	√
	SCK-152X	√	√	√	√	√
	SCK-162X	√	√	√	√	√
	SCK-202	√	√	√	√	√
	SCK-222	√	√		√	√
	SCK-252	√	√	√	√	√
	SCK-302	√	√	√	√	√
	SCK-472	√	√	√	√	√
	SCK-502	√	√	√	√	√
SCK-801	√	√	√	√	√	
SCK-1001	√	√	√	√	√	
SCK-1201	√	√	√	√	√	

本体尺寸	认证型号	安规认证				
		UL	cUL	CSA	TUV	CQC
13mm	SCK-013	√	√		√	√
	SCK-1R37	√	√		√	√
	SCK-2R56	√	√	√	√	√
	SCK-045	√	√		√	√
	SCK-4R74	√	√		√	√
	SCK-055	√	√	√	√	√
	SCK-074	√	√		√	√
	SCK-084	√	√	√	√	√
	SCK-104	√	√	√	√	√
	SCK-124	√	√	√	√	√
	SCK-153	√	√	√	√	√
	SCK-163	√	√	√	√	√
	SCK-183	√	√	√	√	√
	SCK-203	√	√	√	√	√
	SCK-0R78A	√	√		√	√
	SCK-018	√	√		√	
	SCK-1R38	√	√	√	√	√
	SCK-1R58	√	√	√	√	√
15mm	SCK-028	√	√		√	√
	SCK-2R58	√	√	√	√	√
	SCK-037	√	√	√	√	√
	SCK-046	√	√	√	√	√
	SCK-056	√	√	√	√	√
	SCK-065	√	√	√	√	√
	SCK-075	√	√	√	√	√
	SCK-085	√	√		√	√
	SCK-105	√	√	√	√	√
	SCK-125	√	√	√	√	√
	SCK-154	√	√	√	√	√
	SCK-164	√	√	√	√	√
	SCK-184	√	√	√	√	√
	SCK-204	√	√	√	√	√
	SCK-224	√	√		√	√
	SCK-253	√	√	√	√	√
	SCK-303	√	√	√	√	√
	SCK-333	√	√		√	√
SCK-403	√	√	√	√	√	
SCK-473	√	√	√	√	√	

# 负温度系数热敏电阻器：SCK 系列



## 突波电流抑制用功率型热敏电阻器

本体尺寸	认证型号	安规认证			
		UL	cUL	TUV	CQC
20mm	SCK200R7	√	√	√	√
	SCK201R0	√	√	√	√
	SCK201R5	√	√	√	√
	SCK202R0	√	√	√	√
	SCK202R5	√	√	√	√
	SCK203R0	√	√	√	√
	SCK204R0	√	√	√	√
	SCK204R7	√	√	√	√
	SCK205R0	√	√	√	√
	SCK206R0	√	√	√	√
	SCK206R8	√	√	√	√
	SCK207R0	√	√	√	√
	SCK208R0	√	√	√	√
	SCK20100	√	√	√	√
	SCK20120	√	√	√	√
	SCK20130	√	√	√	√
	SCK20150	√	√	√	√
	SCK20160	√	√	√	√
	SCK20180	√	√	√	√
	SCK20200	√	√	√	√
25mm	SCK251R0	√	√	√	√
	SCK251R5	√	√	√	√
	SCK252R0	√	√	√	√
	SCK252R5	√	√	√	√
	SCK253R0	√	√	√	√
	SCK254R0	√	√	√	√
	SCK254R7	√	√	√	√
	SCK255R0	√	√	√	√
	SCK256R8	√	√	√	√
	SCK257R0	√	√	√	√
	SCK258R0	√	√	√	√
	SCK25100	√	√	√	√
	SCK25120	√	√	√	√
	SCK25150	√	√	√	√
	SCK25180	√	√	√	√
SCK25200	√	√	√	√	

本体尺寸	认证型号	安规认证			
		UL	cUL	TUV	CQC
30mm	SCK301R0	√	√	√	√
	SCK301R5	√	√	√	√
	SCK302R0	√	√	√	√
	SCK302R5	√	√	√	√
	SCK303R0	√	√	√	√
	SCK304R0	√	√	√	√
	SCK304R7	√	√	√	√
	SCK305R0	√	√	√	√
	SCK306R8	√	√	√	√
	SCK307R0	√	√	√	√
	SCK308R0	√	√	√	√
	SCK30100	√	√	√	√
	SCK30120	√	√	√	√
	SCK30150	√	√	√	√
	SCK30180	√	√	√	√
	SCK30200	√	√	√	√



# 负温度系数热敏电阻器：SCK 系列



## 突波电流抑制用功率型热敏电阻器

### 最大电流减额曲线

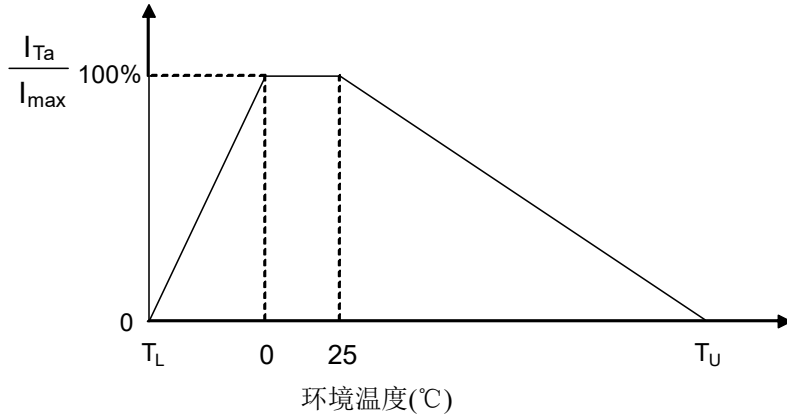

$T_U$ ：工作温度上限( $^{\circ}C$ )

$T_L$ ：工作温度下限( $^{\circ}C$ )

例如：

环境温度( $T_a$ ) = 60 $^{\circ}C$

工作温度上限( $T_U$ ) = 200 $^{\circ}C$

$$I_{Ta} = [1 - (T_a - 25) / (T_U - 25)] \times I_{max} = 80\% I_{max}$$

环境温度( $T_a$ ) = -10 $^{\circ}C$

工作温度下限( $T_L$ ) = -40 $^{\circ}C$

$$I_{Ta} = [1 - (0 - T_a) / (0 - T_L)] \times I_{max} = 75\% I_{max}$$

### 电阻-温度特性曲线

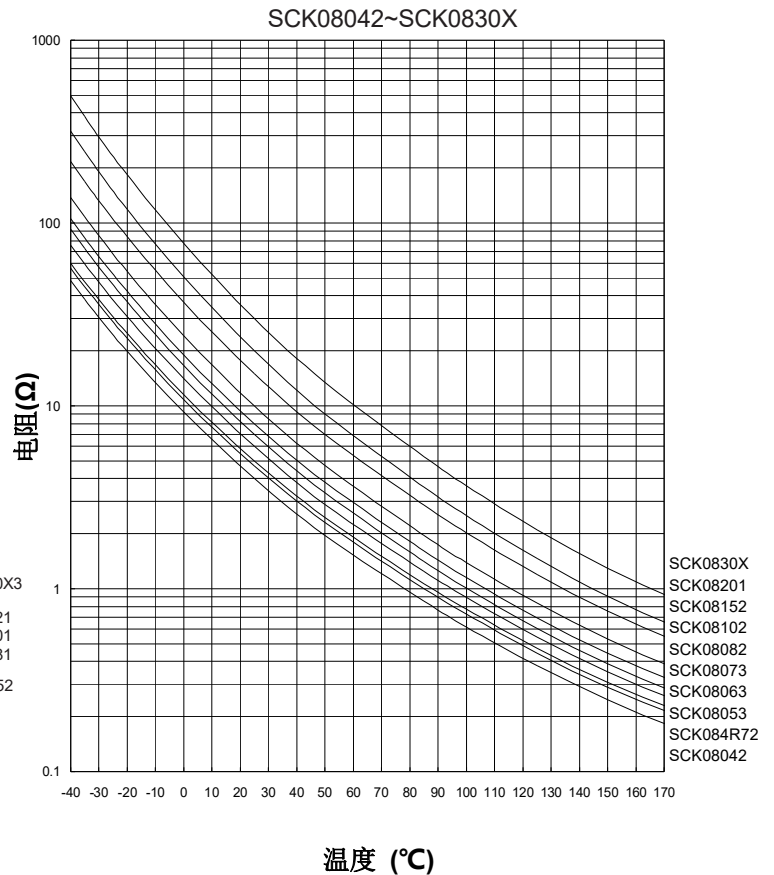
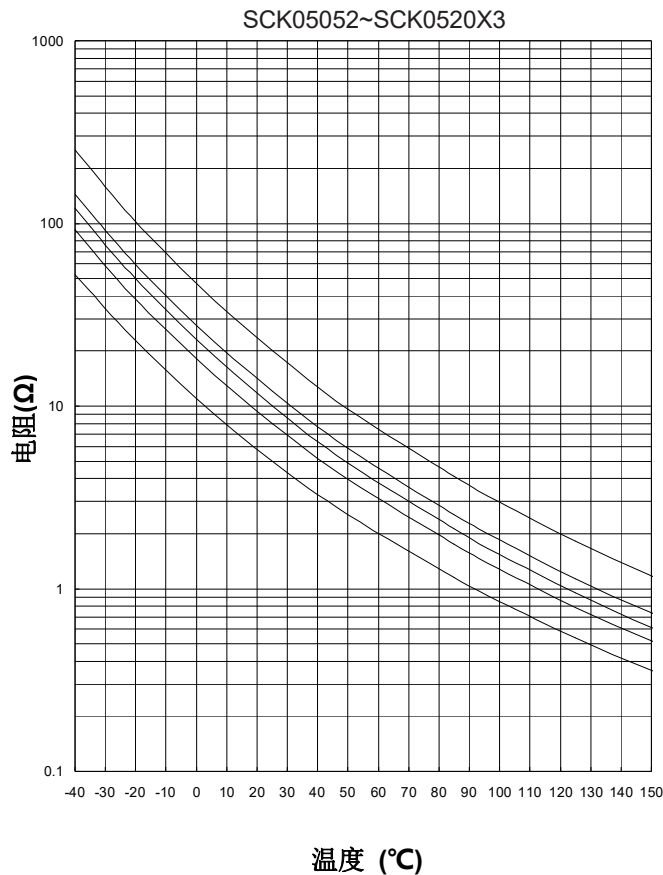

# 负温度系数热敏电阻器：SCK 系列



## 突波电流抑制用功率型热敏电阻器

### ■ 电阻-温度特性曲线

SCK10015~SCK101201

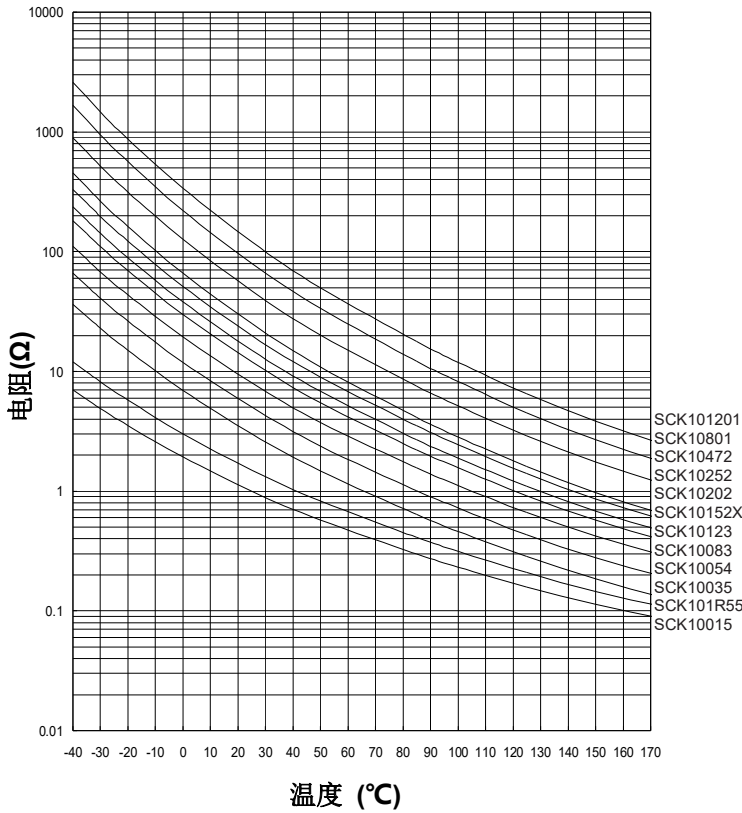

SCK101R35~SCK101001

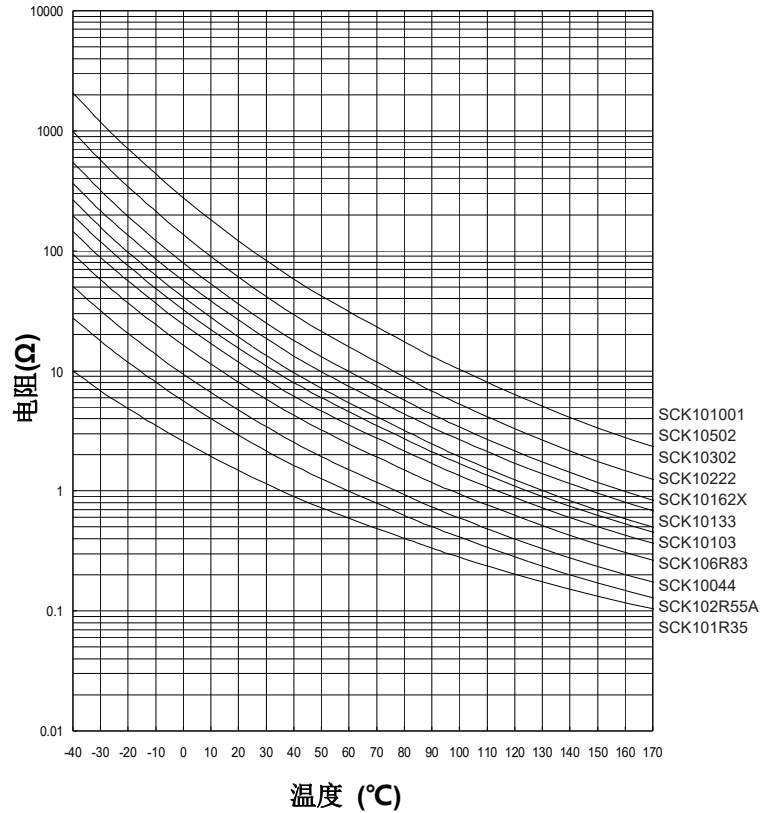

SCK13013~SCK13183

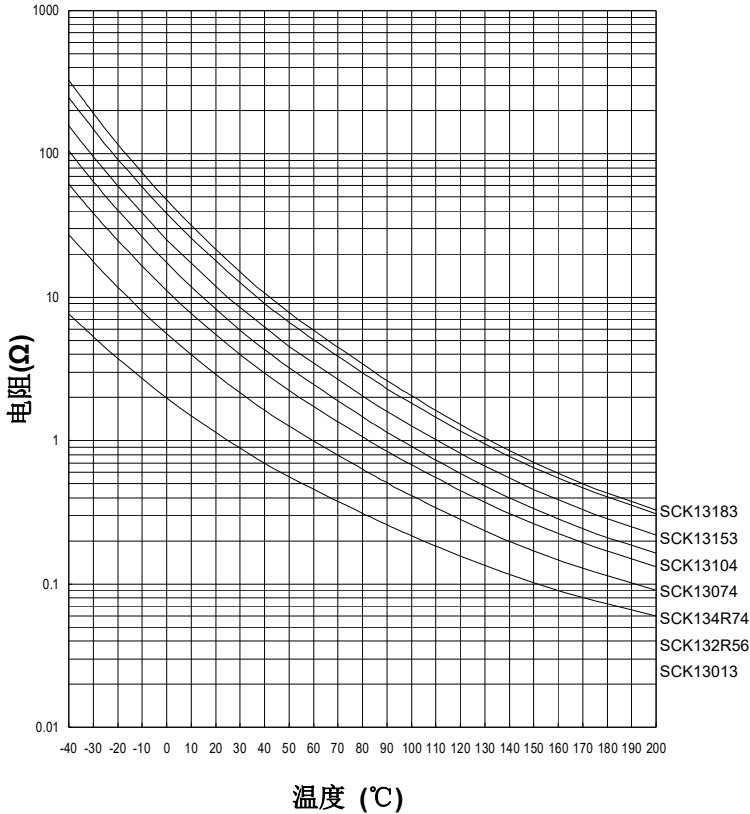

SCK131R37~SCK13203

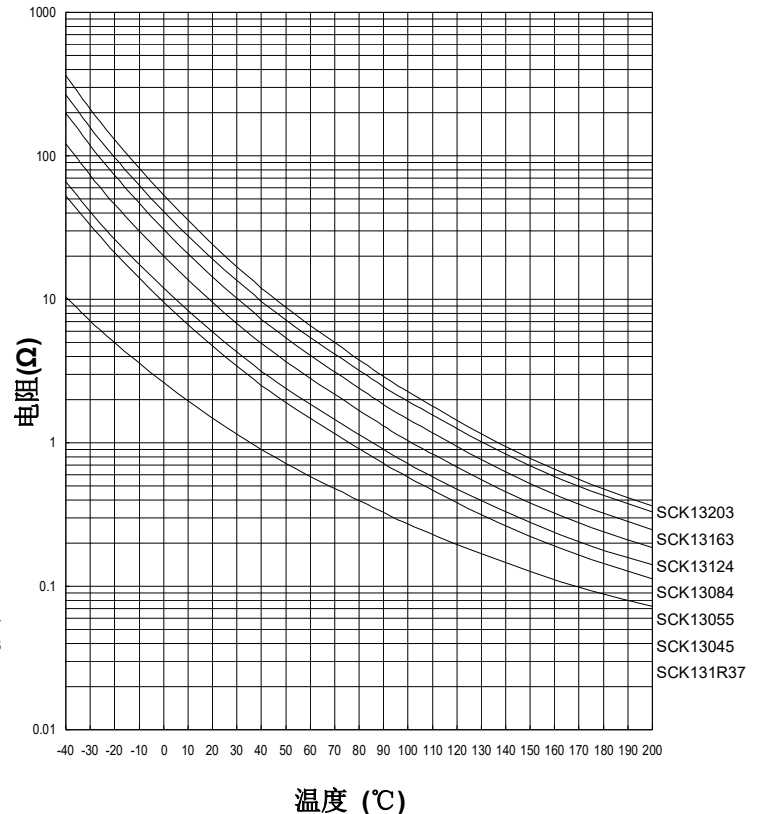

# 负温度系数热敏电阻器：SCK 系列



## 突波电流抑制用功率型热敏电阻器

### ■ 电阻-温度特性曲线

SCK150R78A~SCK151202

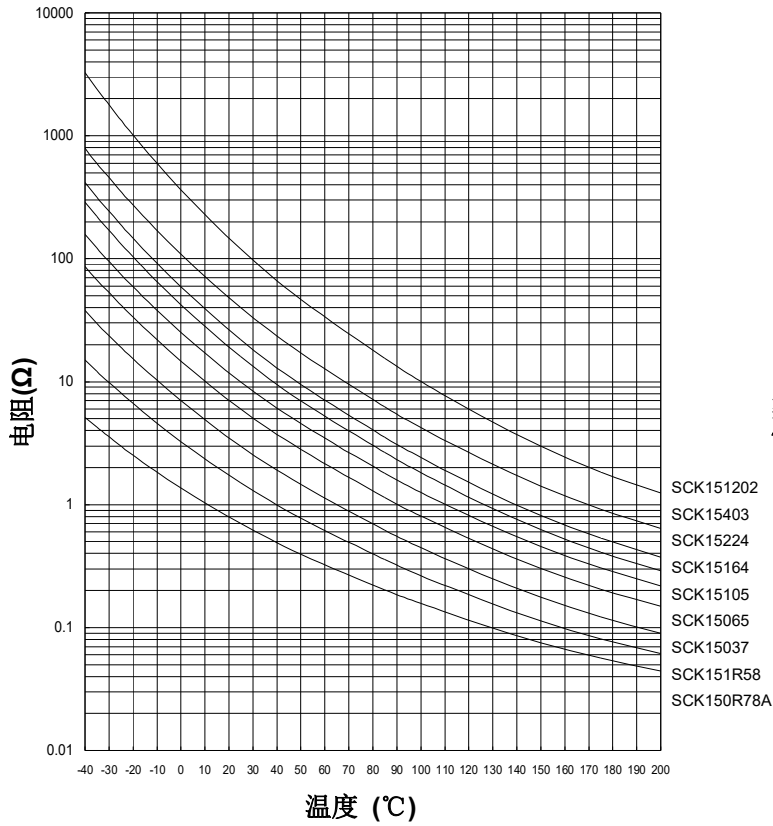

SCK15016~SCK15473

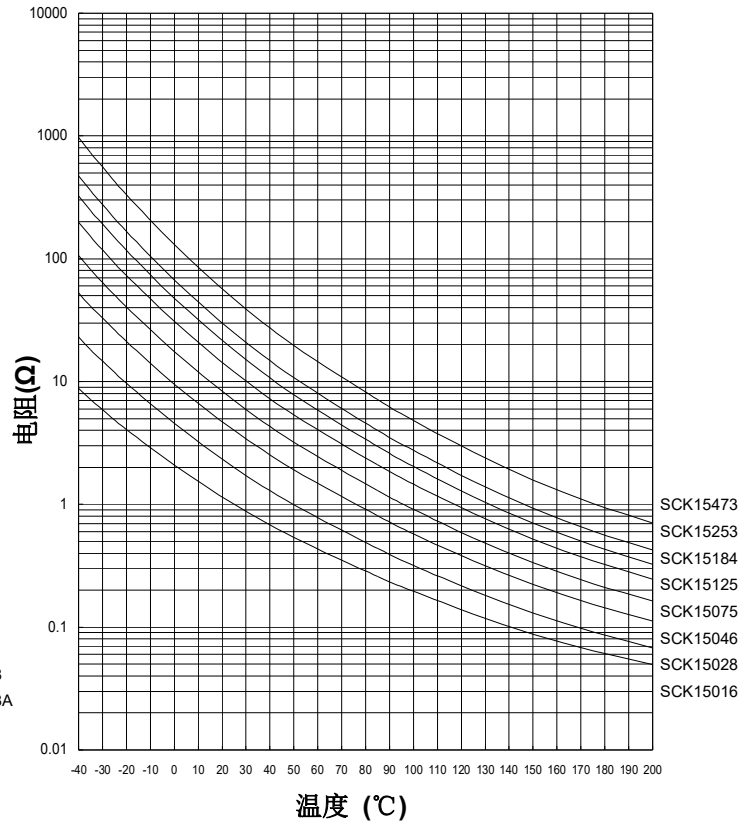

SCK151R38~SCK15802X

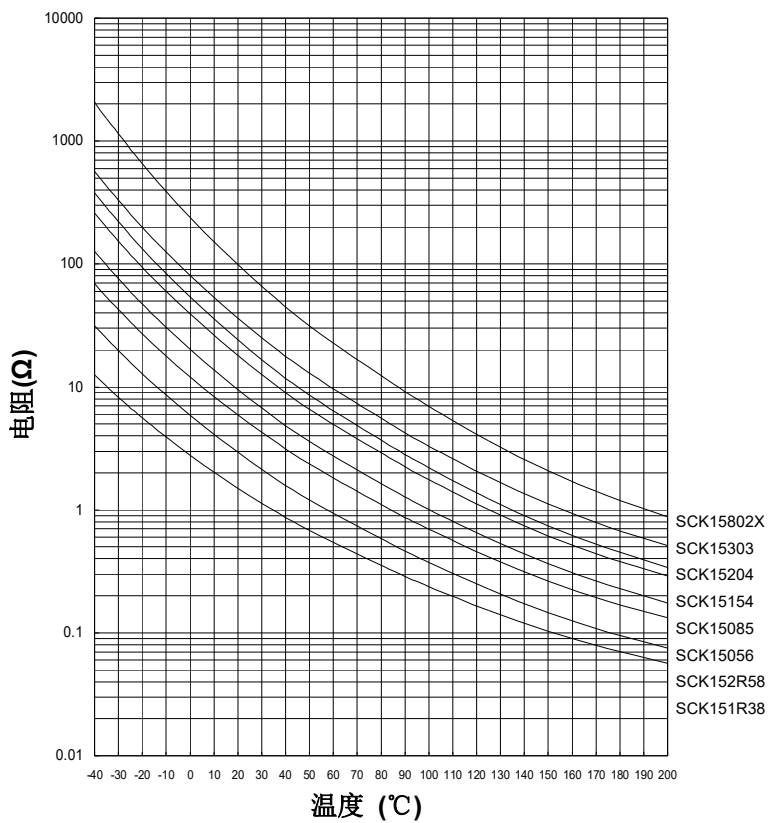

SCK200R7~SCK20180

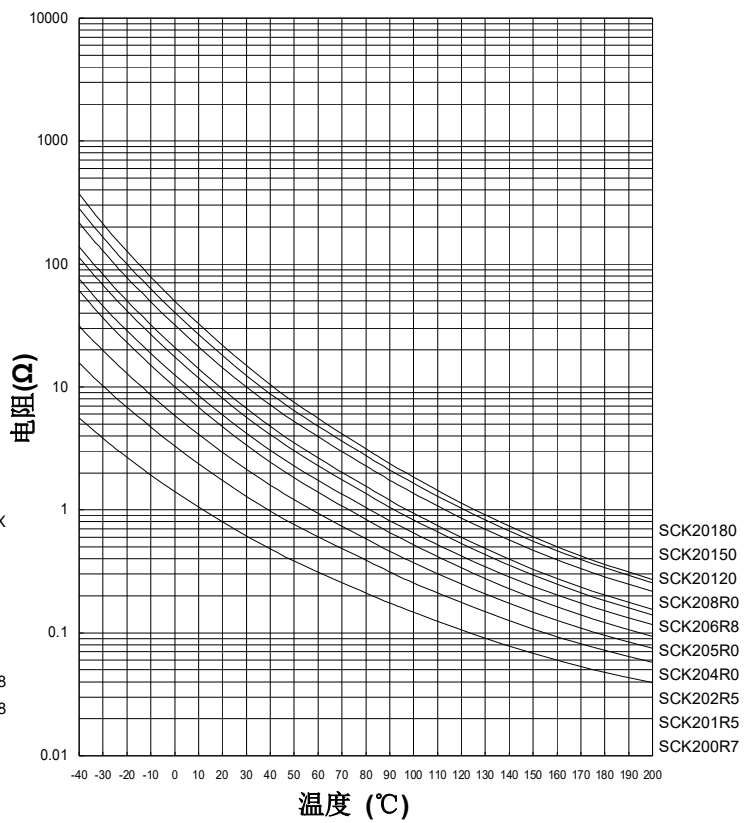

# 负温度系数热敏电阻器：SCK 系列



## 突波电流抑制用功率型热敏电阻器

### ■ 电阻-温度特性曲线

SCK201R0~SCK20200

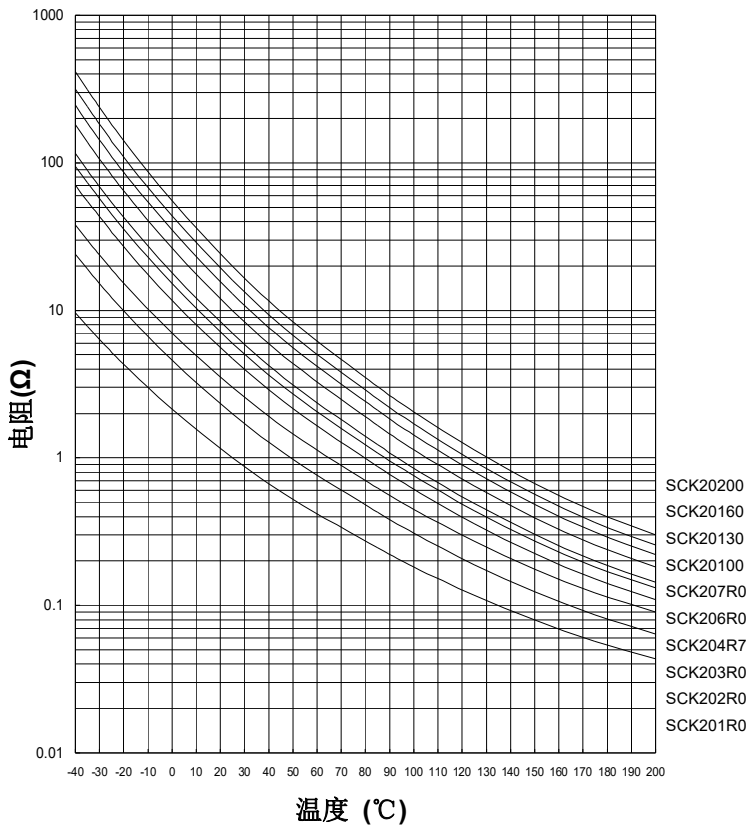

SCK251R0~SCK25180

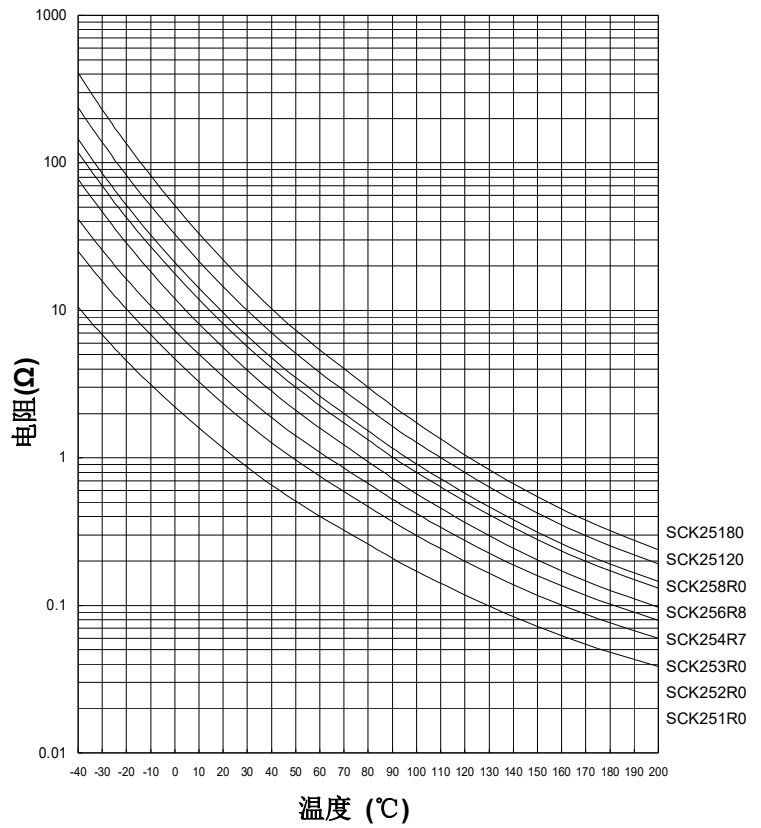

SCK251R5~SCK25200

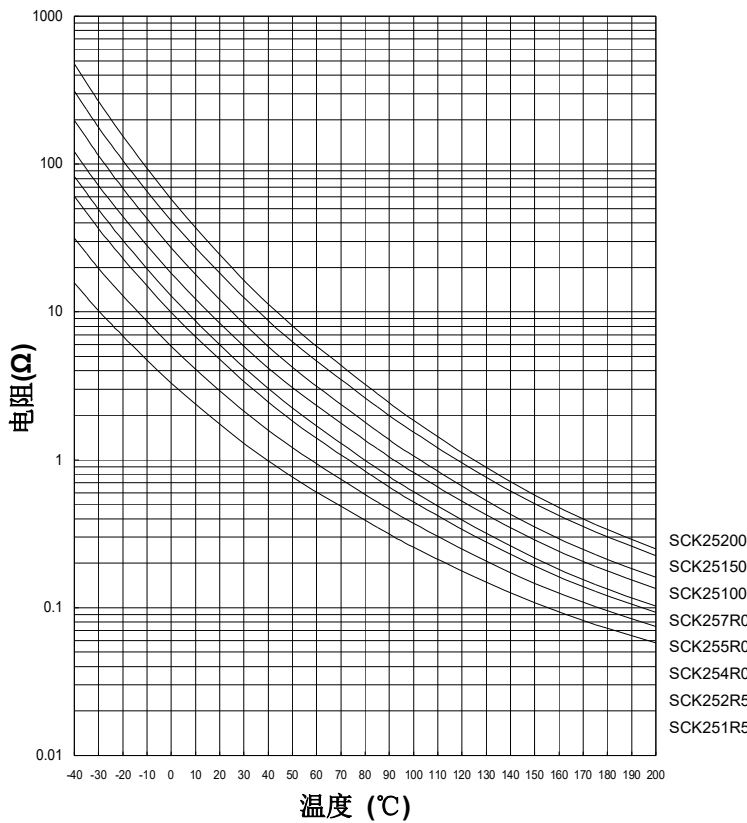

SCK301R0~SCK30180

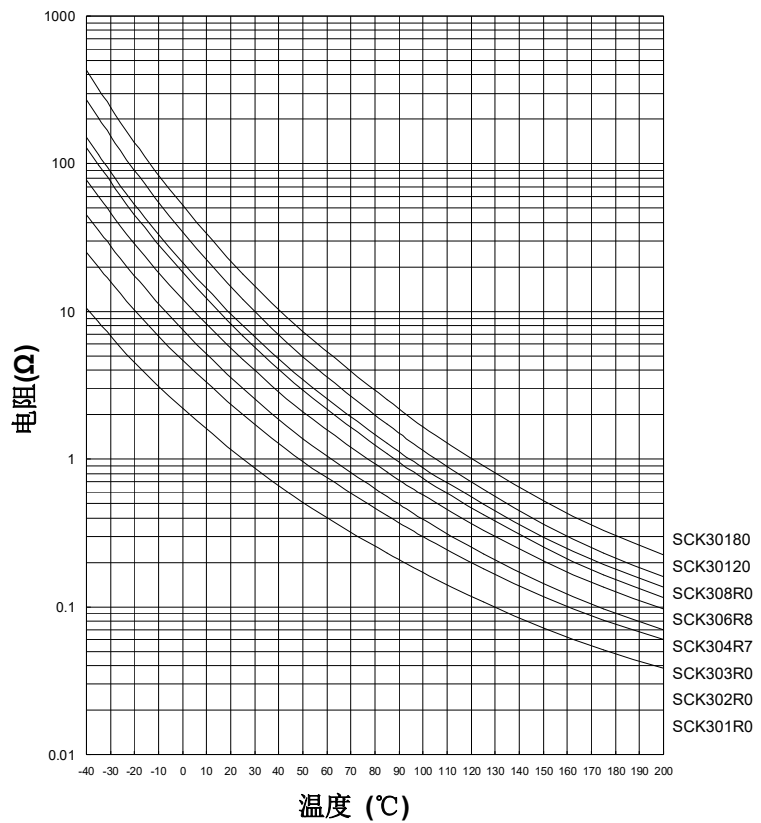

# 负温度系数热敏电阻器：SCK 系列



## 突波电流抑制用功率型热敏电阻器

### ■ 电阻-温度特性曲线

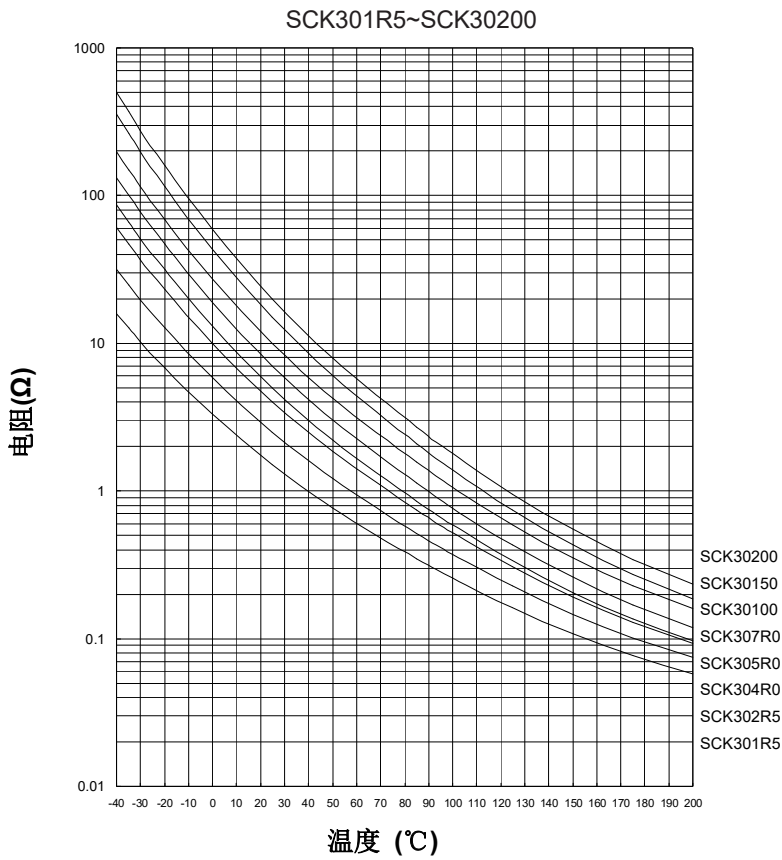

# 负温度系数热敏电阻器：SCK 系列



## 突波电流抑制用功率型热敏电阻器

### ■ 电压-电流特性曲线（代表性曲线）

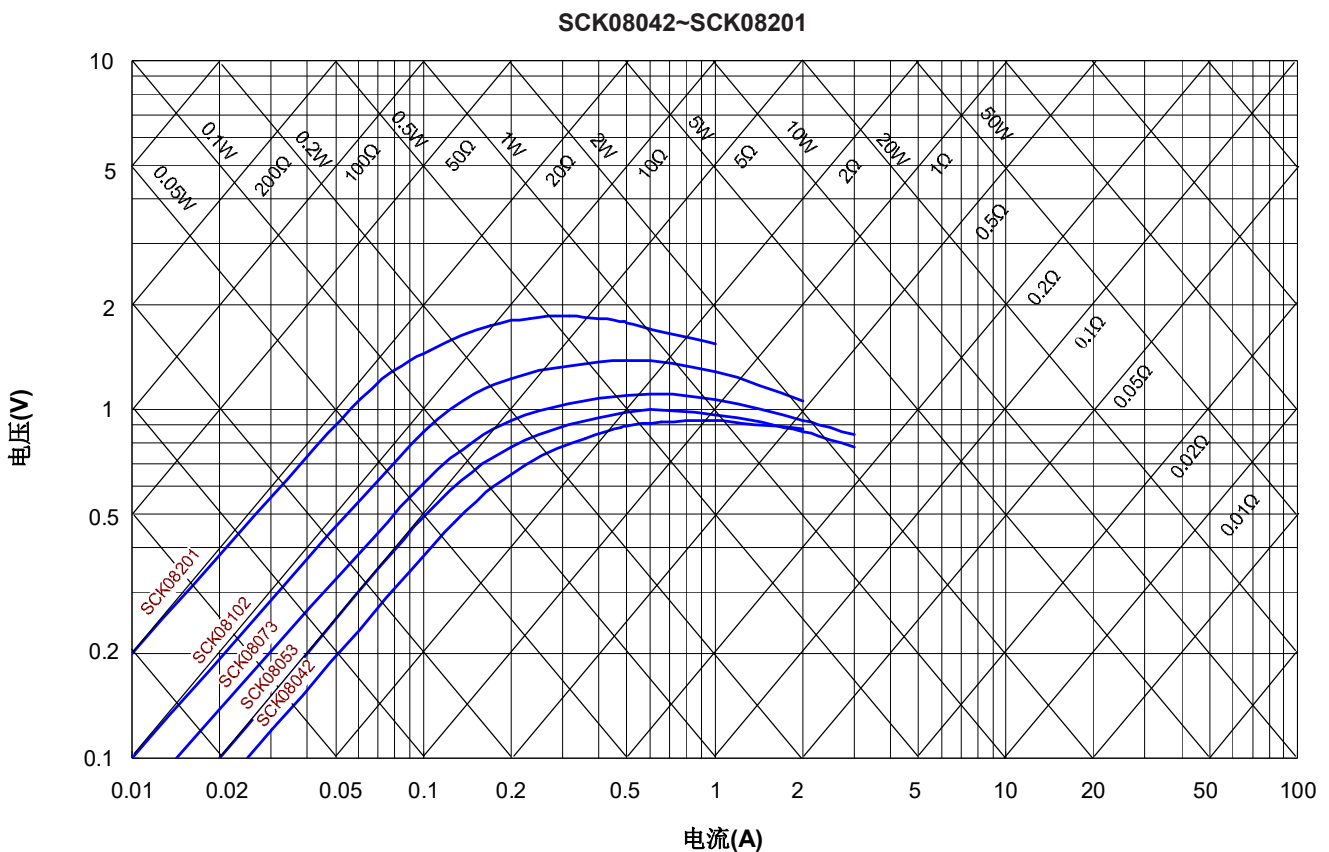
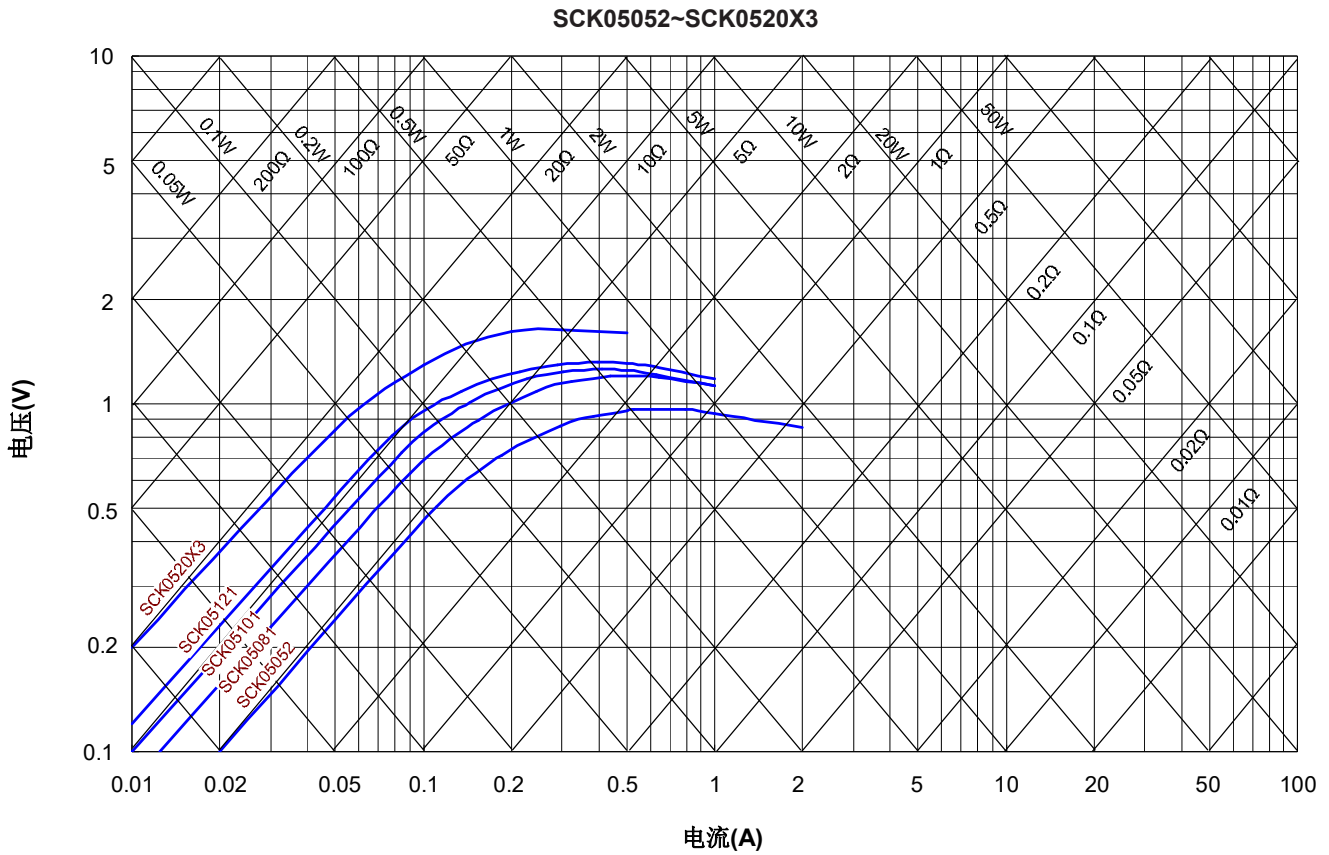

# 负温度系数热敏电阻器：SCK 系列



## 突波电流抑制用功率型热敏电阻器

SCK10015~SCK10222

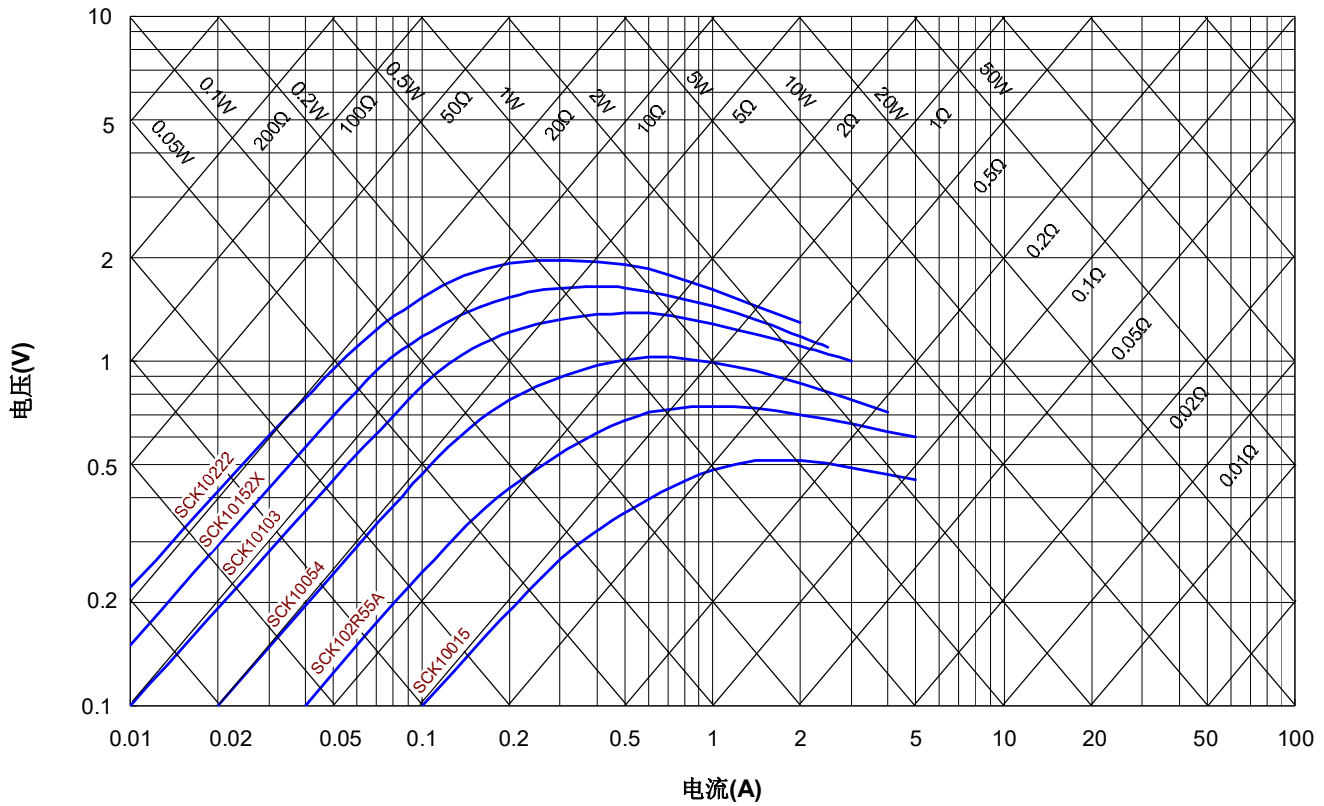

SCK131R37~SCK13203

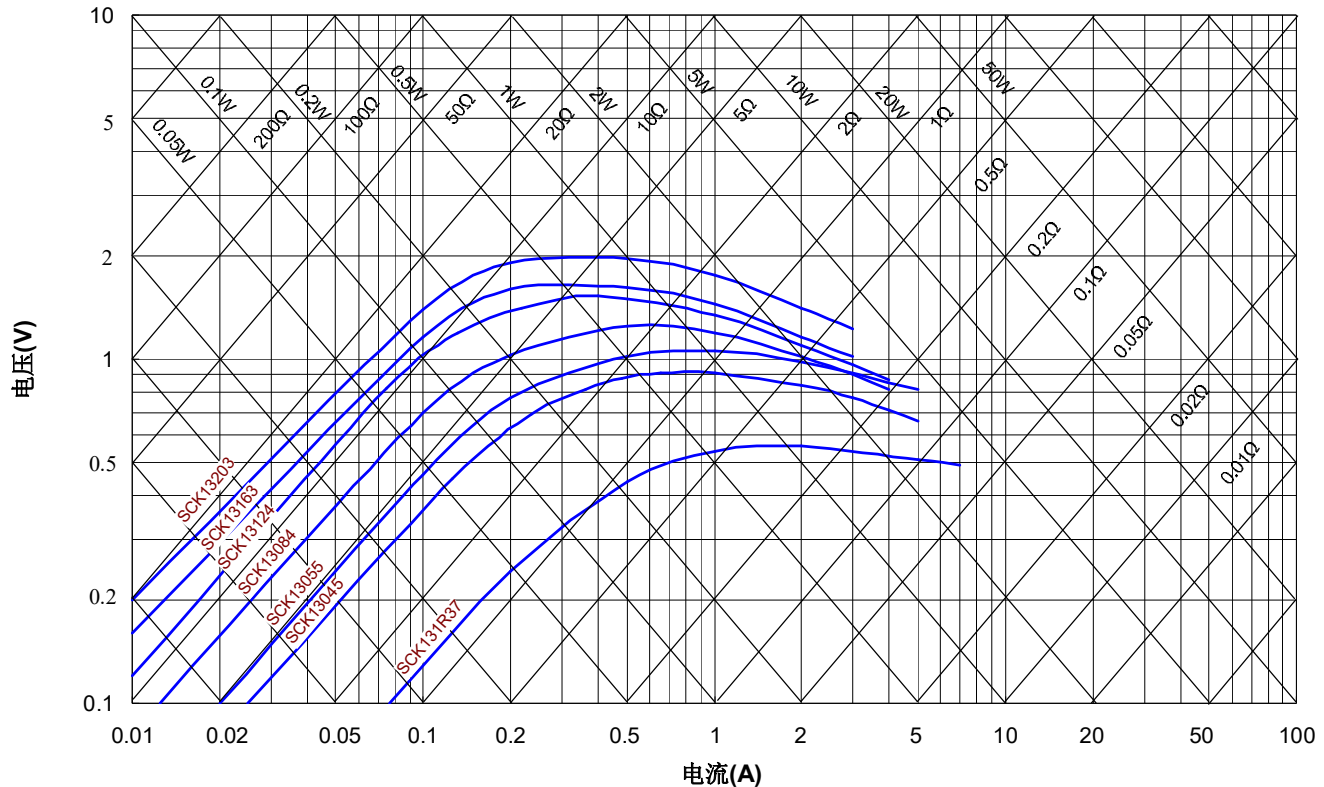

# 负温度系数热敏电阻器：SCK 系列



## 突波电流抑制用功率型热敏电阻器

SCK151R38~SCK15303

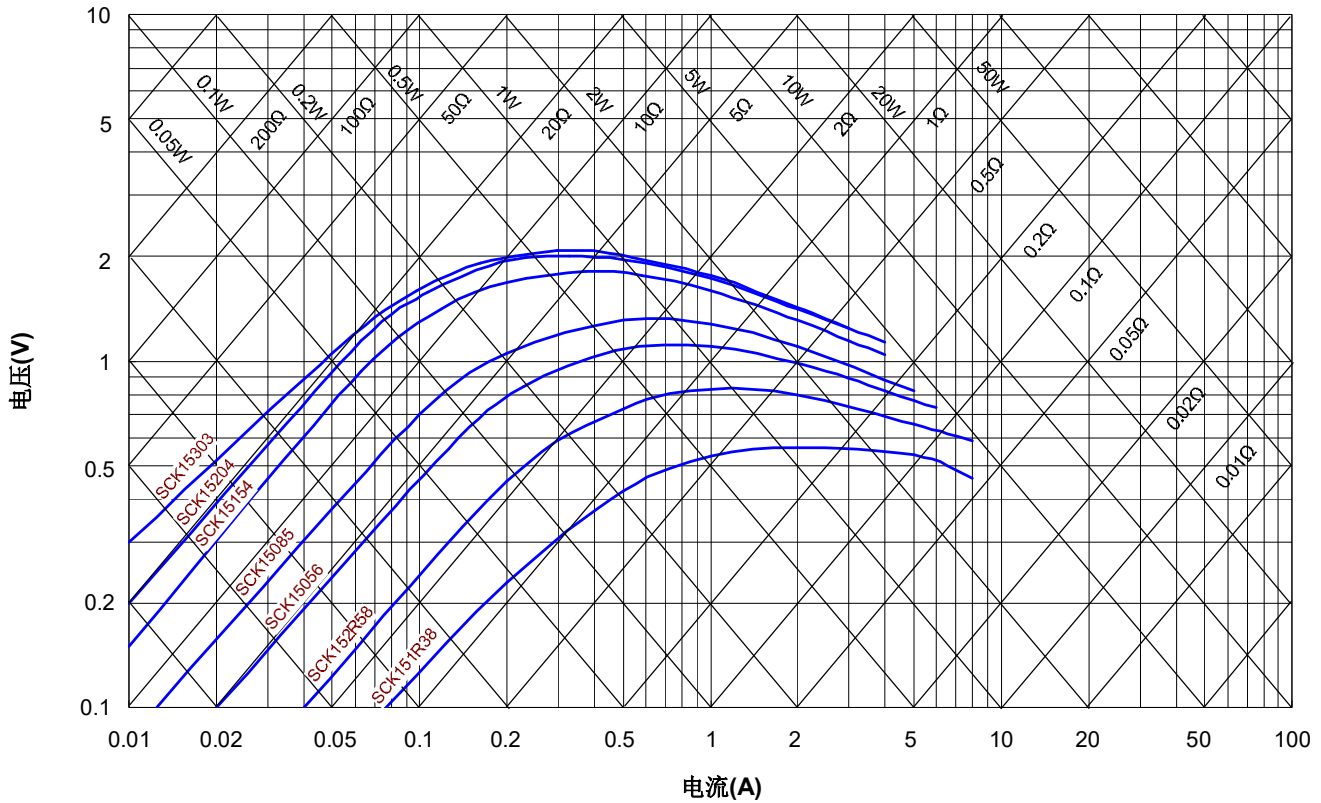

SCK200R7~SCK20200

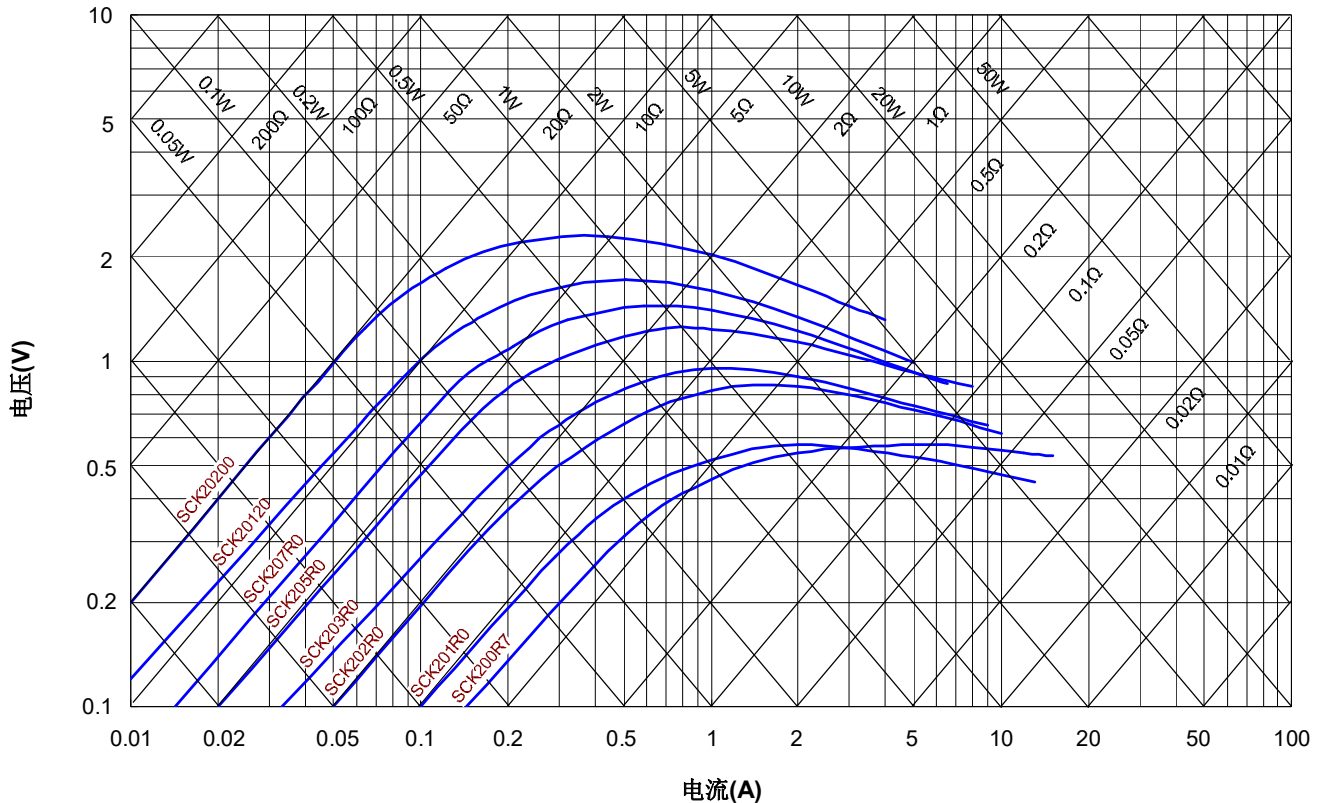



# 负温度系数热敏电阻器：SCK 系列



## 突波电流抑制用功率型热敏电阻器

SCK251R0~SCK25121

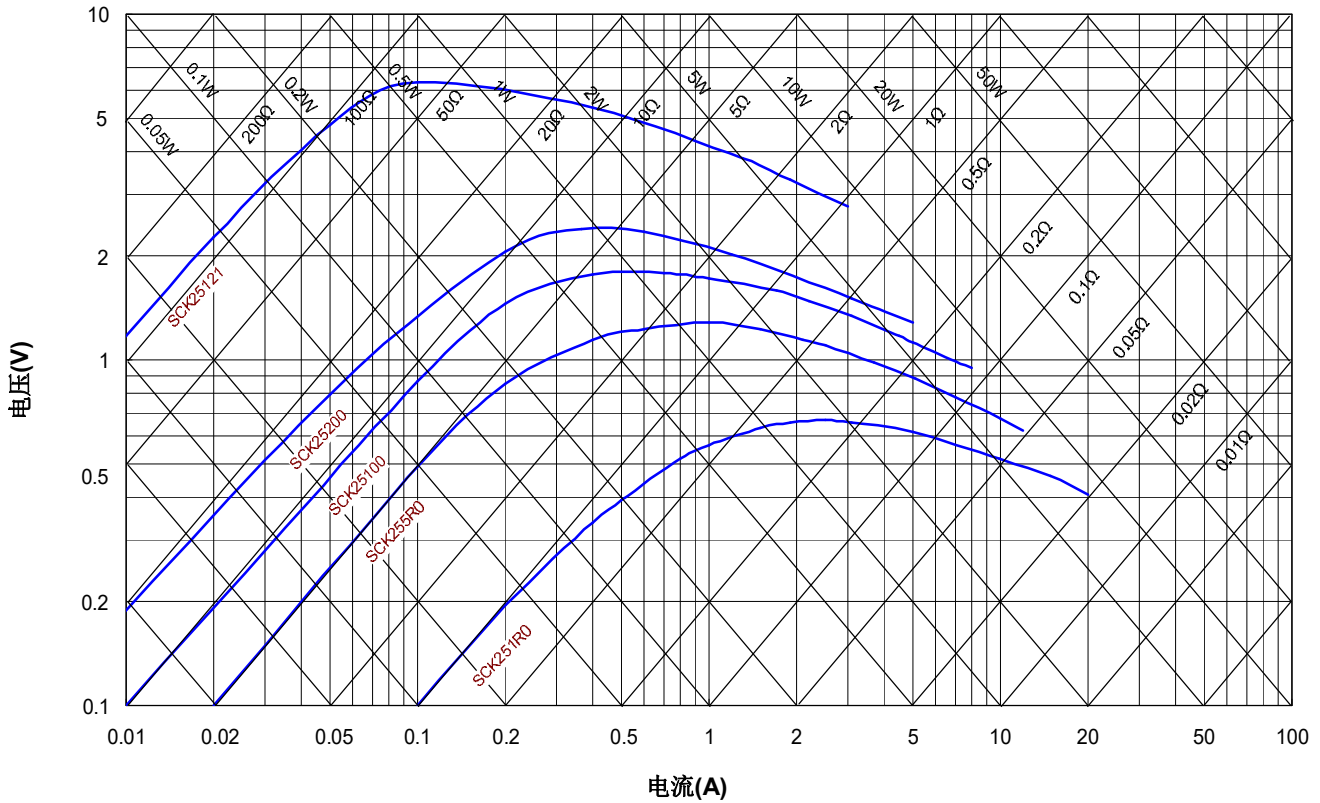

SCK301R0~SCK30200

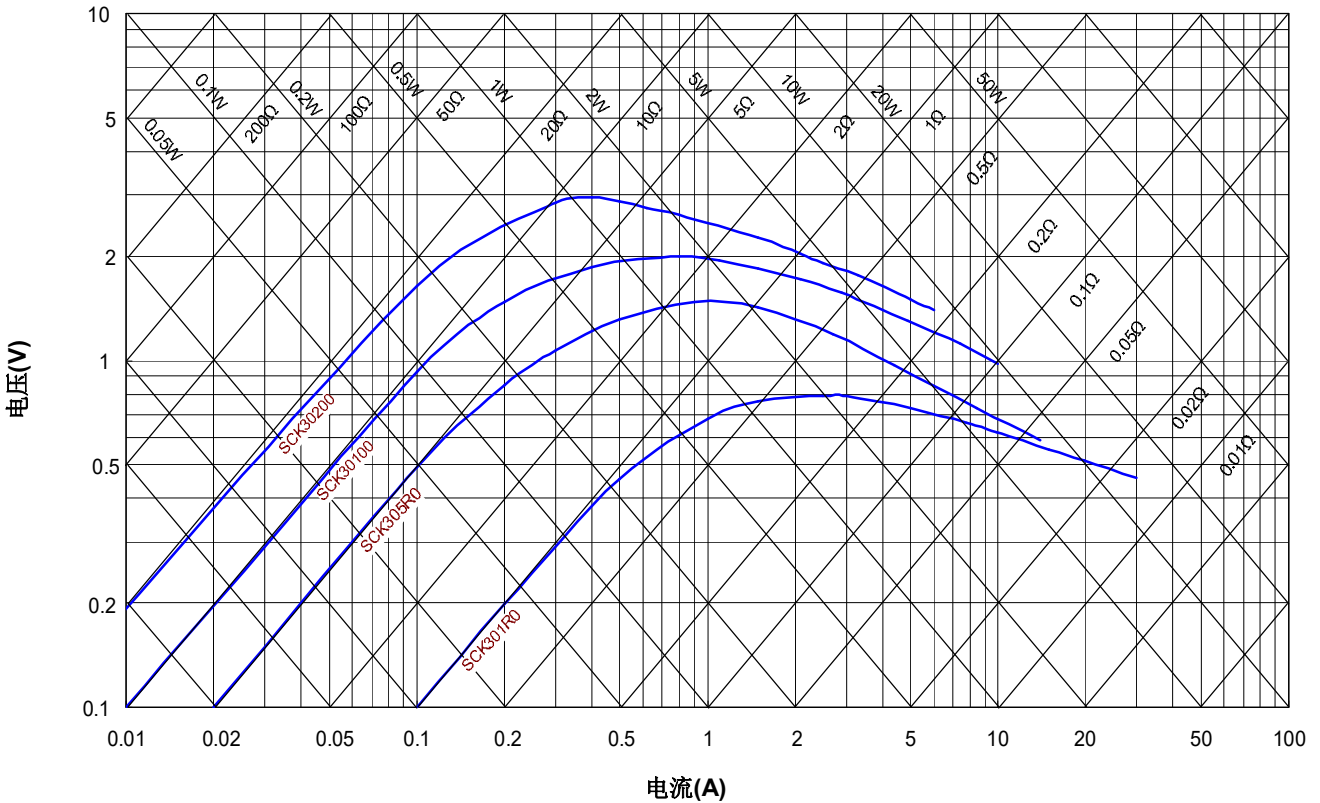

# 负温度系数热敏电阻器：SCK 系列



## 突波电流抑制用功率型热敏电阻器

### ■ 推荐焊接条件

#### ● 波峰焊曲线

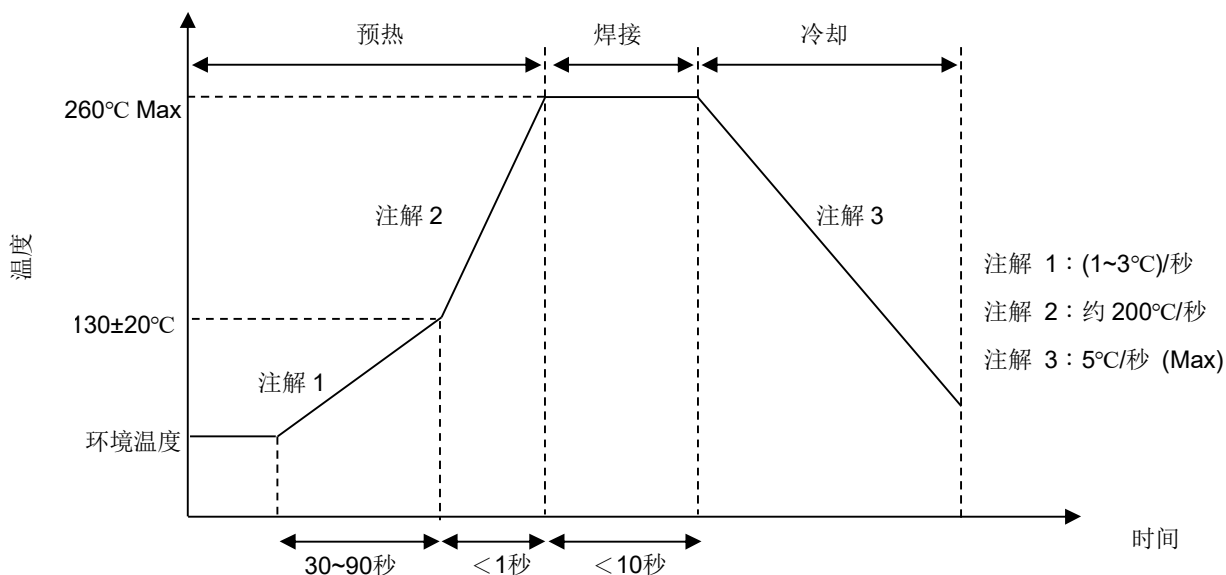

#### ● 建议重工烙铁条件

项目	条件
烙铁头部温度	360°C (max.)
焊接时间	3 sec. (max.)
焊接位置与涂装层距离	2 mm (min.)

# 负温度系数热敏电阻器：SCK 系列



## 突波电流抑制用功率型热敏电阻器

### ■ 可靠性

试验项目	测试标准	试验条件 / 方法	性能要求															
引出端强度	IEC 60068-2-21	<p>渐近的方式施加指定的重量，并且在固定位置维持 <math>10 \pm 1</math> 秒。</p> <table border="1"> <thead> <tr> <th>线径 (mm)</th> <th>引线直接下拉力 (Kg)</th> </tr> </thead> <tbody> <tr> <td><math>0.5 &lt; d \leq 0.80</math></td> <td>1.0</td> </tr> <tr> <td><math>0.8 &lt; d \leq 1.25</math></td> <td>2.0</td> </tr> </tbody> </table>	线径 (mm)	引线直接下拉力 (Kg)	$0.5 < d \leq 0.80$	1.0	$0.8 < d \leq 1.25$	2.0	$ \Delta R_{25}/R_{25}  \leq 10\%$									
线径 (mm)	引线直接下拉力 (Kg)																	
$0.5 < d \leq 0.80$	1.0																	
$0.8 < d \leq 1.25$	2.0																	
可焊性	IEC 60068-2-20	$245 \pm 3^\circ\text{C}$ , $3 \pm 0.3$ 秒	着锡面积 $\geq 95\%$															
耐焊接热	IEC 60068-2-20	$260 \pm 3^\circ\text{C}$ , $10 \pm 1$ 秒	无外观损伤 $ \Delta R_{25}/R_{25}  \leq 10\%$															
高温储存	IEC 60068-2-2	$T_U \pm 5^\circ\text{C}$ , $1000 \pm 24$ 小时	无外观损伤 $ \Delta R_{25}/R_{25}  \leq 20\%$															
稳态湿热	IEC 60068-2-78	$40 \pm 2^\circ\text{C}$ , 90~95% RH, $1000 \pm 24$ 小时	无外观损伤 $ \Delta R_{25}/R_{25}  \leq 20\%$															
温度快速变化	IEC 60068-2-14	<p>温度急变按下表条件循环 5 个周期。</p> <table border="1"> <thead> <tr> <th>步骤</th> <th>温度 (<math>^\circ\text{C}</math>)</th> <th>周期 (分钟)</th> </tr> </thead> <tbody> <tr> <td>1</td> <td><math>T_L \pm 5</math></td> <td><math>30 \pm 3</math></td> </tr> <tr> <td>2</td> <td>室温</td> <td><math>5 \pm 3</math></td> </tr> <tr> <td>3</td> <td><math>T_U \pm 5</math></td> <td><math>30 \pm 3</math></td> </tr> <tr> <td>4</td> <td>室温</td> <td><math>5 \pm 3</math></td> </tr> </tbody> </table>	步骤	温度 ( $^\circ\text{C}$ )	周期 (分钟)	1	$T_L \pm 5$	$30 \pm 3$	2	室温	$5 \pm 3$	3	$T_U \pm 5$	$30 \pm 3$	4	室温	$5 \pm 3$	无外观损伤 $ \Delta R_{25}/R_{25}  \leq 20\%$
步骤	温度 ( $^\circ\text{C}$ )	周期 (分钟)																
1	$T_L \pm 5$	$30 \pm 3$																
2	室温	$5 \pm 3$																
3	$T_U \pm 5$	$30 \pm 3$																
4	室温	$5 \pm 3$																
最大电流 ( $I_{max}$ )	IEC 60539-1 4.26.1	$25 \pm 5^\circ\text{C}$ , $I_{max}$ , $1000 \pm 24$ 小时	无外观损伤 $ \Delta R_{25}/R_{25}  \leq 20\%$															
耐久性 (OnOff)	规格标准	$25 \pm 5^\circ\text{C}$ , $I_{max}$ , $C_{th}$ , 1 分钟 通 / 5 分钟 断 x 1000 周期 $C_{th} = 240 \text{ Vac}$ 下的建议电容值	无外观损伤 $ \Delta R_{25}/R_{25}  \leq 20\%$															
绝缘测试	MIL-STD-202F -Method 302	$1000 \text{ V}_{DC}$ , 1 分钟	$\geq 500 \text{ M}\Omega$															

# 负温度系数热敏电阻器：SCK 系列



## 突波电流抑制用功率型热敏电阻器

### ■ 包装方式

#### ● 编带包装方式

##### S 型(直脚)



图 A



图 B

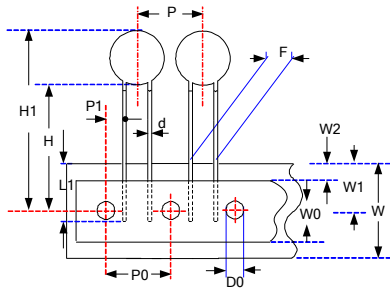

图 C

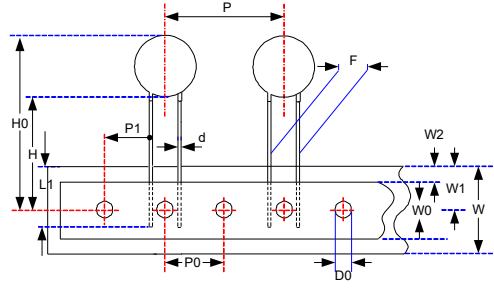

(单位: mm)

编带尺寸	本体尺寸	P <sub>0</sub>	F	P	P <sub>1</sub>	H	H <sub>1</sub>	d	W <sub>0</sub>	W <sub>1</sub>	W <sub>2</sub>	W	ΔP	Δh	L <sub>1</sub>	D <sub>0</sub>	T	图形
		±0.3	±0.5	±1	±0.7	+2/-0	Max.	±0.02	±1.5	+0.75/-0.5	Max.	+1/-0.5	Max.	Max.	Min.	±0.2	±0.2	
P <sub>0</sub> :12.7	05	12.7	4.0	12.7	4.35	18	28	0.8	12	9	3	18	1	2	9	4	0.6	A
	08	12.7	5.0	12.7	3.85	18	30	0.8	12	9	3	18	1	2	9	4	0.6	A
	10	12.7	5.0	12.7	3.85	18	32	0.8	12	9	3	18	1	2	9	4	0.6	A
	13	12.7	7.5	25.4	8.95	18	35	0.8	12	9	3	18	1	2	9	4	0.6	B
	15	12.7	7.5	25.4	8.95	18	37	1.0	12	9	3	18	1	2	9	4	0.6	B
	20	12.7	7.5	25.4	8.95	18	42	1.0	12	9	3	18	1	2	9	4	0.6	B
P <sub>0</sub> :15.0	05	15.0	4.0	15.0	5.50	18	28	0.8	12	9	3	18	1	2	9	4	0.6	A
	08	15.0	5.0	15.0	5.00	18	30	0.8	12	9	3	18	1	2	9	4	0.6	A
	10	15.0	5.0	15.0	5.00	18	32	0.8	12	9	3	18	1	2	9	4	0.6	A
	13	15.0	7.5	15.0	3.75	18	35	0.8	12	9	3	18	1	2	9	4	0.6	A
	15	15.0	7.5	30.0	3.75	18	37	1.0	12	9	3	18	1	2	9	4	0.6	C
	20	15.0	7.5	30.0	3.75	18	42	1.0	12	9	3	18	1	2	9	4	0.6	C

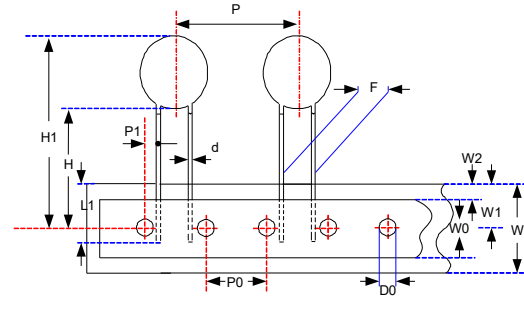
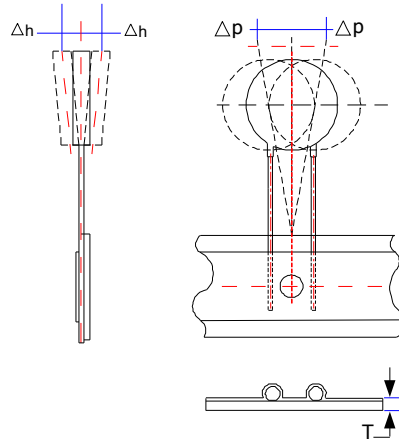
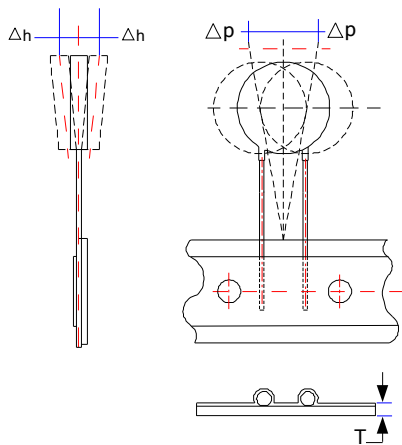
# 负温度系数热敏电阻器：SCK 系列



## 突波电流抑制用功率型热敏电阻器

### F 型 (Y 型引脚)



图 A



图 B

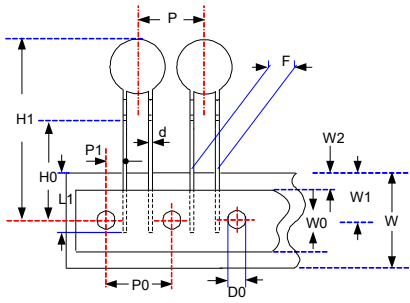

图 C

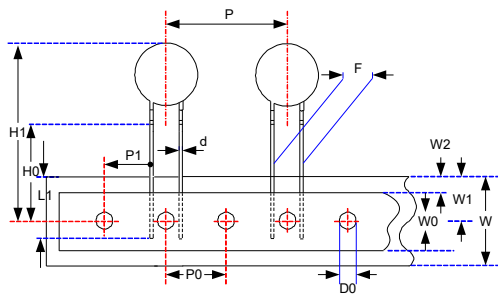

(单位: mm)

编带尺寸	本体尺寸	P <sub>0</sub>	F	P	P <sub>1</sub>	H <sub>0</sub>	H <sub>1</sub>	d	W <sub>0</sub>	W <sub>1</sub>	W <sub>2</sub>	W	ΔP	Δh	L <sub>1</sub>	D <sub>0</sub>	T	图形
		±0.3	±0.5	±1	±0.7	±0.5	Max.	±0.02	±1.5	+0.75 /-0.5	Max.	+1/ -0.5	Max.	Max.	Min.	±0.2	±0.2	
P <sub>0</sub> :12.7	05	12.7	4.0	12.7	4.35	16	28	0.8	12	9	3	18	1	2	9	4	0.6	A
	08	12.7	5.0	12.7	3.85	16	30	0.8	12	9	3	18	1	2	9	4	0.6	A
	10	12.7	5.0	12.7	3.85	16	32	0.8	12	9	3	18	1	2	9	4	0.6	A
	13	12.7	7.5	25.4	8.95	16	35	0.8	12	9	3	18	1	2	9	4	0.6	B
	15	12.7	7.5	25.4	8.95	16	37	1.0	12	9	3	18	1	2	9	4	0.6	B
	20	12.7	7.5	25.4	8.95	16	42	1.0	12	9	3	18	1	2	9	4	0.6	B
P <sub>0</sub> :15.0	05	15.0	4.0	15.0	5.50	16	28	0.8	12	9	3	18	1	2	9	4	0.6	A
	08	15.0	5.0	15.0	5.00	16	30	0.8	12	9	3	18	1	2	9	4	0.6	A
	10	15.0	5.0	15.0	5.00	16	32	0.8	12	9	3	18	1	2	9	4	0.6	A
	13	15.0	7.5	15.0	3.75	16	35	0.8	12	9	3	18	1	2	9	4	0.6	A
	15	15.0	7.5	30.0	3.75	16	37	1.0	12	9	3	18	1	2	9	4	0.6	C
	20	15.0	7.5	30.0	3.75	16	42	1.0	12	9	3	18	1	2	9	4	0.6	C

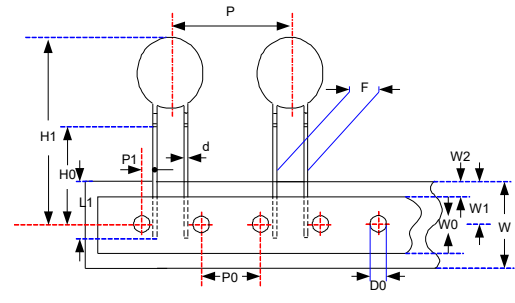
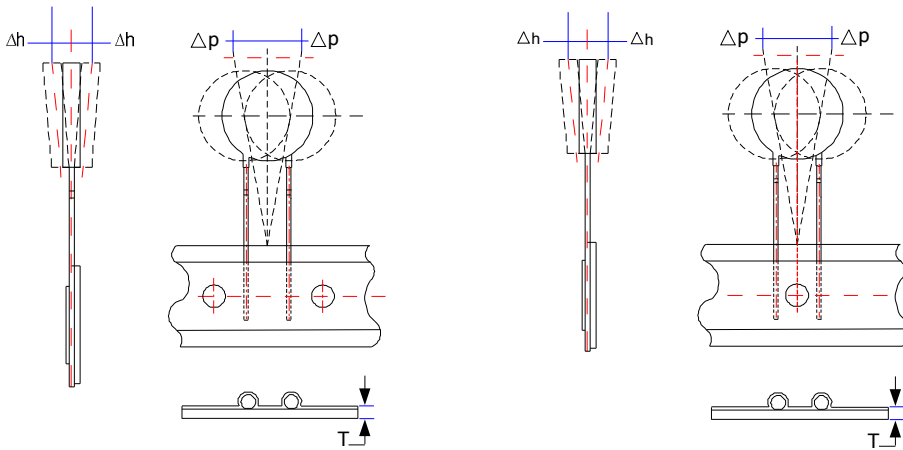
# 负温度系数热敏电阻器：SCK 系列



## 突波电流抑制用功率型热敏电阻器

### ■ 包装数量

#### ● 散装

系列	直脚型数量 (pcs/袋)	切脚型数量 (pcs/袋)	L 型引脚数量 (pcs/袋)
SCK05	250	500	---
SCK08	250	250	200
SCK10	200	250	200
SCK13	100	200	100
SCK15	100	100	100
SCK20	500 (pcs/盒)	50	50
SCK25	396 (pcs/盒)	396 (pcs/盒)	---
SCK30	396 (pcs/盒)	396 (pcs/盒)	---

#### ● 卷轴包装

系列	D (mm)	D1 (mm)	W (mm)	数量 (pcs/卷)
SCK05	340±10	31±1	46±1	2,000
SCK08				1,500
SCK10				1,500
SCK13				750
SCK15			55±1	750
SCK20				500

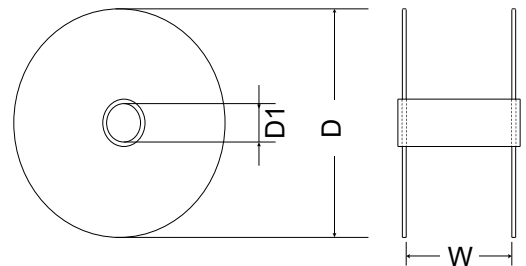

#### ● 盒装

系列	数量 (pcs/盒)
SCK05	1,500
SCK08	1,300
SCK10	1,300
SCK13	600 (P <sub>0</sub> 12.7mm) 1,000 (P <sub>0</sub> 15.0mm)
SCK15	500
SCK20	500

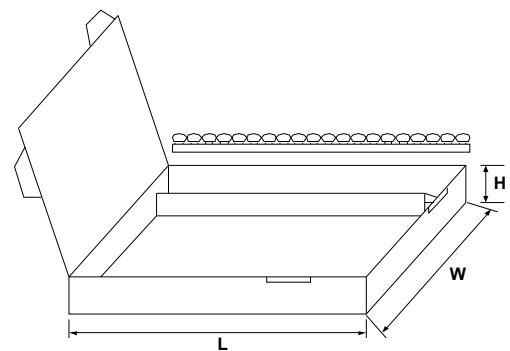

(单位: mm)

本体尺寸	L	W	H
Φ5~Φ20	345	275	55

### ■ 仓库存储条件

#### ● 存储条件：

1. 存储温度：-10°C~+40°C
2. 相对湿度：≤75%RH
3. 不要将本产品存放在有腐蚀性气体或是阳光直接照射的环境中保管

#### ● 存储期限：1年