

FEATURES

- ◆ Meet EPS Level 6
- ◆ Built-in 650V Power MOSFET
- ◆ Proprietary **super-QR/PSR™** (Quasi-Resonant & Primary Side Regulation) Control for High Efficiency and Low EMI
- ◆ Proprietary Cable Drop Compensation
- ◆ Max. Frequency Clamping to Limit Power MOSFET Vds Spike @ Output Short Circuit
- ◆ Less than 70mW Standby Power
- ◆ $\pm 5\%$ CC and CV Precision
- ◆ Multi-Mode Control
- ◆ Cycle-by-Cycle Current Limiting
- ◆ Leading Edge Blanking (LEB)
- ◆ Soft Start
- ◆ Output Over Voltage Protection
- ◆ VDD UVLO, OVP & Clamp

APPLICATIONS

- ◆ Battery chargers for cellular phones, cordless phones, PDA, digital cameras, etc
- ◆ Replaces linear transformer and RCC SMPS
- ◆ AC/DC LED lighting

GENERAL DESCRIPTION

SF6773V is a high performance, highly integrated QR (Quasi Resonant Mode) and Primary Side Regulation (PSR) power switch for offline small power converter applications.

SF6773V has proprietary **super-QR/PSR™** control for high efficiency and low EMI, which can ensure system to meet EPS Level 6 energy standard. The IC also has built-in cable drop compensation function to achieve excellent CV performance.

SF6773V uses **Multi Mode Control** to improve efficiency and reliability and to decrease audio noise energy @ light loadings. SF6773V also integrates the function of "**Max. Frequency Clamping @ Output Short Circuit**" to limit power MOSFET Vds spike when output short circuit occurs.

SF6773V integrates functions and protections of FB Short Protection, Under Voltage Lockout (UVLO), VDD Over Voltage Protection (VDD OVP), Output Over Voltage Protection (Output OVP), Soft Start, Cycle-by-cycle Current Limiting (OCP), Pin Floating Protection, VDD Clamping.

SF6773V is available in SOP7 package.

TYPICAL APPLICATION

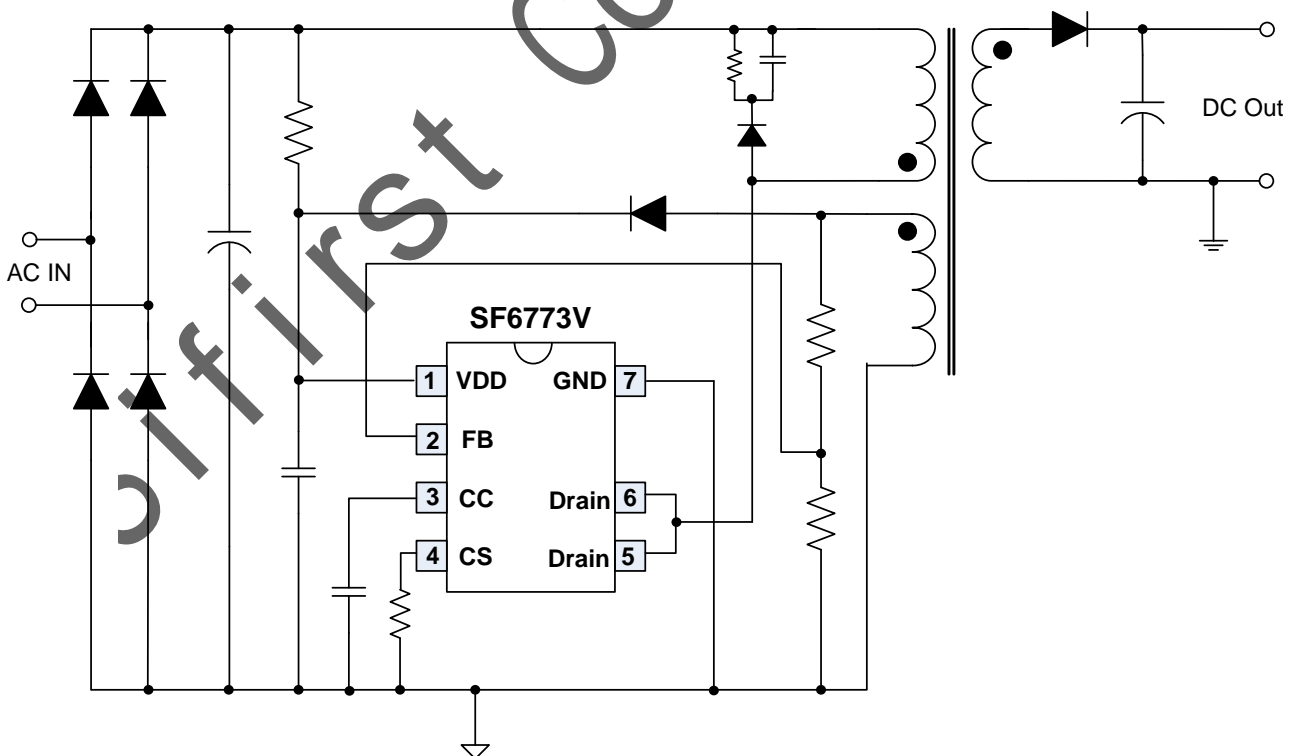

Pin Configuration

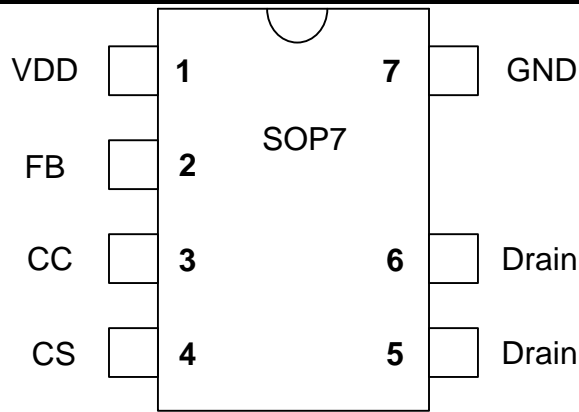

Ordering Information

Part Number	Top Mark	Package		Tape & Reel
SF6773VTG	SF6773VTG	SOP7	Green	
SF6773VTGT	SF6773VTG	SOP7	Green	Yes

Output Power Table⁽¹⁾

Part Number	230VAC \pm 15% ⁽²⁾	85-265VAC
	Adapter ⁽³⁾	Adapter ⁽³⁾
SF6773V	17W	13W

Note 1. The Max. output power is limited by junction temperature

Note 2. 230VAC or 100/115VAC with doublers

Note 3. Typical continuous power in a non-ventilated enclosed adapter with sufficient drain pattern as a heat sink at 50°C ambient.

Marking Information

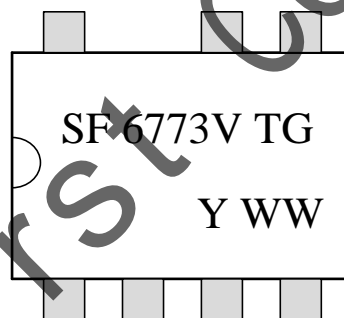

YWW: Year&Week code

Pin Description

Pin Num	Pin Name	I/O	Description
1	VDD	P	IC power supply pin.
2	FB	I	System feedback pin. This control input regulates both the output voltage in CV mode and output current in CC mode based on the flyback voltage of the auxiliary winding.
3	CC	O	Connect a capacitor between this pin and GND for CC regulation.
4	CS	I	Current sense pin.
5-6	Drain	P	High voltage power MOSFET drain connection.
7	GND	P	Ground